

Modeling and Control, of Glycolysis in *Trypanosoma brucei*.

Ilona W.M. Verburg
Department of Mathematics, Faculty of Science, Vrije Universiteit
De Boelelaan 1083, 1081 HV Amsterdam, The Netherlands
Email ilonaverburg@hotmail.com

Draft March 2, 2006

Contents

| | |
|--|------------|
| Preface | iii |
| 1 Introduction | 1 |
| 2 Problem formulation | 4 |
| 3 Dynamical systems for biochemical reaction networks | 6 |
| 3.1 Procedure of Biochemical Modelling | 7 |
| 3.2 Biochemical modelling of glycolysis in <i>Trypanosoma brucei</i> . | 12 |
| 3.3 Michaelis-Menten Reaction Kinetics | 17 |
| 3.3.1 Michaelis-Menten Type Equation for One Substrate . | 18 |
| 3.3.2 Michaelis-Menten Type Equation for Two Substrates . | 23 |
| 3.4 Procedure of Mathematical Modelling | 26 |
| 3.5 Mathematical Modelling of Glycolysis in <i>Trypanosoma Brucei</i> | 31 |
| 3.5.1 Dynamical system | 31 |
| 3.5.2 Reduction of state variables | 44 |
| 3.5.3 The system of differential equations after reduction of state variables | 45 |
| 3.5.4 Determination of output variables | 46 |
| 4 Dynamical System Properties | 49 |
| 4.1 Positive systems for biochemical reaction networks | 50 |
| 4.2 Positivity of the model for <i>Trypanosoma brucei</i> | 53 |
| 4.3 Steady state | 56 |
| 4.4 Steady state properties of a dynamical system | 57 |
| 4.5 Numeric determination of the steady state | 64 |
| 4.6 Steady state for the model of <i>Trypanosoma brucei</i> | 67 |

| | | |
|----------|--|------------|
| 5 | Control of Dynamical Systems | 71 |
| 5.1 | Motivation | 71 |
| 5.2 | Problems and approaches | 72 |
| 5.3 | Control for rational drug design | 77 |
| 5.4 | Control design for glycolysis in <i>Trypanosoma brucei</i> | 82 |
| 6 | Conclusions | 89 |
| A | Glycolysis of <i>Trypanosoma Brucei</i> | 93 |
| A.1 | Introduction | 93 |
| A.2 | Biochemical model | 95 |
| A.3 | Mathematical model | 100 |
| A.3.1 | Notations, definitions, terminology | 100 |
| A.3.2 | Rate equations | 103 |
| A.3.3 | Differential equations | 112 |
| A.3.4 | Moiety-conservation relations | 117 |
| A.3.5 | Pools | 119 |
| A.3.6 | Fast dynamics | 121 |
| A.3.7 | Algebraic equations | 123 |
| A.3.8 | Reduction of state variables | 125 |
| A.3.9 | The reduced system | 130 |
| A.3.10 | Determination of the output | 133 |
| A.4 | Positivity of the system | 137 |
| A.5 | Steady state of the system | 144 |
| A.5.1 | Graph of the system | 144 |
| A.5.2 | Numerical determination of steady state | 148 |
| A.6 | Control of the output, ATP, of the system | 159 |
| A.6.1 | Formulation for the Graph | 159 |
| A.6.2 | Maple program for the graph theoretic approach | 163 |
| A.6.3 | Numerical determination of steady state | 168 |
| B | List of All Equations | 170 |
| C | List of Abbreviations | 173 |
| | Bibliography | 176 |

Preface

This project is carried out at the Department of Analysis at the Vrije Universiteit, in Amsterdam,. The subject is modelling and control of glycolysis in *Trypanosoma brucei*. This project arose because of the interest of my first supervisor, to understand biochemical reaction networks, especially control of biochemical reaction networks. Since I study mathematics with life sciences, the subject captured my interest as well. This project is supervised by Prof. dr. ir. J.H. van Schuppen, mainly working at Centrum voor wiskunde en Informatica (CWI) in Amsterdam and Prof. dr. A.C.M Ran as second supervisor, working at the Vrije Universiteit, in Amsterdam. I enjoyed working on this project, even when it was a stressful the last few weeks and still there are interesting questions open. I can say that I have learned a lot during the period working on the problems described in this report.

I would like to thank Jan van Schuppen and André Ran for supervising me in this project, and Barbara Bakker, from the Faculty Earth and Life Sciences, Department of Molecular Cell Physiology, at the Vrije Universiteit in Amsterdam, for the use of her thesis, ‘Glycolysis of *Trypanosoma brucei*’, and for answering my questions.

Ilona W.M Verburg
Amstelveen, 9 February 2006

Chapter 1

Introduction

The title of my thesis is ‘Modeling and Control, of Glycolysis in *Trypanosoma brucei*’. This report is addressed to all researchers interested in the above mentioned subject, both mathematicians and biologists. The main problem of this project is development of control theory for biochemical reaction networks.

The theory discussed in this report will be applied to the model of glycolysis of *Trypanosoma brucei*, as described in the thesis of B.M. Bakker. The biochemical model is developed by P. Michels and co-workers, from the Institute for Cellular Pathology, Université Catholique de Louvain, Brussels, Belgium.

Trypanosoma brucei is the parasite that causes the African sleeping disease. This disease is transmitted to humans through the bite of a tsetse fly. *Trypanosoma brucei* is a unicellular, eucaryotic organism. The tsetse fly feeds itself with the blood of animals and humans. When a person is bitten by an infected fly, *Trypanosoma brucei* proliferate and invades almost all the organs of the body of the host.

In most cases the immune system of the host can destroy the parasites, but some *Trypanosomes* can attack the immune system, and finally destroy it. In this phase symptoms of human trypanosomiasis are high fever, a headache, weakness, and pruritus. In advanced stages of the disease the parasite will invade the central nervous system, this is the reason of behavior change of patients. Another common symptom in the advanced stage is sleeping for long periods of the day and having insomnia at night. When the disease is untreated the person will die within several months or years after the infection [24], [25].

For the above disease very little medication is available, and the drugs that are available are often not working very effectively. We know that *Trypanosomes* live in the bloodstream of humans where its ATP supply

is depending only on glycolysis. This when glycolysis cannot take place, *Trypanosoma brucei* do not have any energy supply. This, the pathway of glycolysis can be important for rational drug design.

During glycolysis in *Trypanosoma brucei*, glucose is converted into pyruvate and glycerol in several steps. During this process ATP is produced, which is the cells energy supply. In *Trypanosoma brucei* glycolysis takes place in an organelle called the glycosome. In humans glycolysis will take place in the cytosol. An idea for drug design is using the glycolysis to control the output variables, which can be ATP or Pyruvate. In this report control is applied on the particular biochemical reaction network of *Trypanosoma brucei*.

Before discussing the main problem of this report a positive dynamical system is obtained for the model of glycolysis in *Trypanosoma brucei*, after this dynamical system properties, positivity and steady state will be discussed. Finally control of biochemical reaction networks shall be discussed. The structure of the chapters is first describing the theory, which is used and mentioning several ideas. Afterwards the theory will be applied on the biochemical model of glycolysis in *Trypanosoma brucei*. The methods are explained in my report, but most of the results are denoted in the appendix. In the remainder of this chapter the general contents of each chapter will be mentioned.

In Chapter 2 the main problem of this report is formulated in more detail. Also several motivations for this problem are discussed.

In Chapter 3 continuous-time positive dynamical systems for biochemical reaction networks are obtained. First in Section 3.1 obtaining a biochemical model is discussed. Single reactions in a reaction network are described, which can be combined to a network of reaction equations. This is followed by a procedure for determining a biochemical reaction network for the model of glycolysis in *Trypanosoma brucei* in Section 3.2.

To understand biochemical reaction networks a mathematical model will be formulated in Section 3.4. A way to determine a mathematical model is to formulate a dynamical system of differential equations of the reaction system rate equations are used for this approach. The reaction kinetic that is used for most rate equations in the model of glycolysis in *Trypanosoma brucei* is Michaelis-Menten reaction kinetics. In Section 3.3 this will be discussed.

Finally in Section 3.5.1 the mathematical model for glycolysis in *Trypanosoma brucei* formulated by B.B. Bakker is considered in [2]. This model contains a set of differential equations, moiety equations, equilibrium equations and equations for pools of species. The model will be translated first into a model with mathematical notations as used in dynamical system theory. Afterwards, reduction of state variables will take place and the system will be converted. Finally, the output variables will be determined.

Chapter 4 deals with system properties of rational dynamical systems. In this chapter positivity and steady state of a dynamical system are discussed. Since states of systems for biochemical reaction networks are concentrations, these state variables have to be positive. In Section 4.1 definitions and theorems about positivity are mentioned. Afterwards in Section 4.2 positivity of the model of glycolysis in *Trypanosoma brucei* is checked.

After discussing positivity, the property of steady state is considered in Section 4.4. In this section questions about stability, asymptotic stability, and globally asymptotic stability of a steady state are discussed. To discuss these properties the articles [23], and [10], of respectively E.D. Sontag and M. Feinberg are used. In Section 4.6 steady state values are determined numerical for the model of glycolysis in *Trypanosoma brucei*.

In Chapter 5 control of dynamical system will be discussed, with respect to the main problem. Motivations for this subject are problems that arise in drug design, food processing, waste water treatment, and other biotechnology. These motivations are mentioned in Section 5.1. In this section we first want to explain problems to control a specific output, by controlling the input vector. Control theory can be used in this context.

In Section 5.2 the main problem, control of biochemical reaction networks is formulated and four approaches to control biochemical reaction networks with respect to drug design are discussed. These four approaches are: 1) the method of simulation of the steady state, when putting random one or combination of input variables equal to zero; 2) metabolic control theory; 3) control design via abstraction and graph algorithms; 4) control theory for zeroing outputs.

In Section 5.3 the method control design via abstraction and graph algorithms, for control to rational drug design is explained in more detail, because this method will be applied on the model of glycolysis in *Trypanosoma brucei* in Section 5.4. This method makes use of the graph of the biochemical network. Afterwards the cut set method is applied to this graph. Then it will be checked whether a path exist between inflow and outflow. Finally results will be checked with the help of numerical simulation of a new steady state.

In Chapter 6 our results are summarized and the main problem of this report is discussed. Further some open questions that are not considered in this report are mentioned.

Chapter 2

Problem formulation

The aim of this project is the development of control theory for biochemical reaction networks, in particular at the level of a cell of a biological organism. Motivations for this project are: 1) the understanding of the function of the cell, both biochemically and mathematically; 2) rational drug design, determination of chemical substances which inhibit one or more enzymes in a micro-organism so as to disable this organism. This project is also motivated by future biotechnology, such as using the cell to produce particular chemicals. To work out these goals mathematics can be used, such as control and system theory.

In this project the main problem is to develop control theory. This involves modeling biochemical reaction networks as dynamical control systems and analysis of dynamical system properties of such systems. The mathematical model of a biochemical reaction network is in the form of a dynamical system described by a differential equation and algebraical equations. The problem of the project includes development of control laws for zeroing one or more particular outflows based on zeroing of input functions by inhibiting of particular reactions. Finally the problem includes development of control laws to increase one or more particular outflows of the network. This is not including in this report.

The approach to the above problem is the use of control and system theory, in particular for rational positive systems. First a biological model for a biological phenomenon is formulated, followed by a formulation of a mathematical model, as a system of differential equations and algebraic equations. After making a model, dynamical system properties such as positivity of the system, and steady state are determined. Specific questions are to how to determine whether the steady state exists, whether it is unique, and whether it is globally asymptotically stable. The last step is control for rational drug design. The existence problem of an enzyme which is inhibited, results for example in a zeroing of the ATP outflow. This problem can be transformed

into the existence problem of a path in a graph. Inhibition of the production of ATP can be done by limiting the enzyme concentrations in a continuous way. For that situation one also wants to determine whether there exists a new steady state and whether it is unique and asymptotically stable.

Chapter 3

Dynamical systems for biochemical reaction networks

Phenomenon with a dynamic evolution in time are investigated in many diverse areas. Examples of such phenomena are in biology, engineering, economics, physics, and chemical processes. In biology we can consider for example the cycle of a yeast cell or gene expression in the yeast cell. In this chapter modelling for biochemical reaction networks is considered.

In biochemical modeling, models are formulated for biological phenomena. The procedure consists of two steps: 1) from the biological phenomenon to the biological model; 2) from a biological model to a mathematical model.

An example of modeling is that of glycolysis in *Trypanosoma brucei*. This example is used throughout this report. So first the biological organism of *Trypanosoma brucei* is considered. For a biological or physical phenomenon one formulates a biological or physical model. This model consist of a network of reaction equations. In the case of glycolysis in *Trypanosoma brucei* it consists of a network of reaction equations in an organelle called glycosome, this is closely related to peroxisomes.

From a biological or physical model a mathematical model can be made in the form of a dynamical system. A dynamical system is a mathematical structure, often a set of differential equations, which describes the time evolution of a phenomenon. A dynamical system has a state expressed as a collection of numbers. The differential equations describe how the evolution of the future state depends on the current state.

In this chapter the reader will find continuous-time positive dynamical systems for biochemical reaction networks. In a continuous-time positive dynamical system the state is a vector of positive real numbers. First a bio-

chemical model is discussed, this is followed by a procedure for making a dynamical model for glycolysis in *Trypanosoma brucei*.

3.1 Procedure of Biochemical Modelling

First a biochemical process is considered, in an eucaryotic cell or in a reactor for example. One is interested in the functioning of a cell, by using the increased knowledge of the genome of plants and animals. For example, in the communication of the cell with the environment, which reactions take place inside the cell, and what the influence of enzymes is at the reactions inside the cell. To understand biochemical reaction networks, biochemists and mathematicians try to make a mathematical model of the phenomenon, from which they can obtain relations.

Before making a mathematical model a biochemical- or physical model has to be made of a biochemical process. This means making a biochemical reaction network of the process, or when the process is very easy, one single reaction equation. Reactions in a biochemical reaction network are described by single reaction equations, which can be combined to a network of reaction equations. The reaction equations can be either reversible or irreversible.

So to make a biochemical reaction network one first has to investigate, which reactions take place in the process. For example, when a cell is considered one has to investigate which reactions take place inside and outside the cell. This can be done experimentally by biologist or chemists. However it is not always possible to find all single reaction equations of a network. Some networks are too complicated to find all the reaction equations experimentally, other networks are simply too big. For example it can be that one does not know which part of the DNA is responsible for a particular function. When one has determined all of the single differential equations that play a role in the network one can combine them to a system of reaction equations. The processes that take place are often so big, that even if all the reaction equations are known it impossible is to construct a network.

So first we consider single reaction equations. A single reaction equation can be seen as an interaction between reactant molecules. Atoms or groups of atoms rearrange resulting in breaking and forming chemical bonds in a chemical reaction. A biochemical reaction consist of one or more substrates that react, often with the help of enzymes, to form one or more products. A biochemical reaction is always reversible, but often the rate of the backwards reaction is very small and is neglected by biochemists and then we call the reaction irreversible.

A single reaction is of the following type:

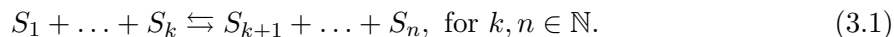

When this reaction is reversible, the reaction proceeds in both directions at the same time, and when it is irreversible, the reaction proceeds in only one direction, usually from left to right.

A biochemical reaction network is a system of biochemical reactions that interact with each other. The product of one of the reactions in the network can for example be a substrate, or a part of the substrates, for another reaction in the network. In a system of biochemical reactions there are often more species and complexes than in a single reaction equation. The number of different biochemical reactions in the network is denoted by r .

The substrates and products that occur in the reaction equations are called chemical species. The number of chemical species is denoted by $n \in \mathbb{N}$ and by S the set of species is denoted. The object on the left side and the object on the right side of a chemical reaction equation are called the complexes of a chemical reaction equation. The number of complexes of the chemical reaction is denoted by $m \in \mathbb{N}$, and the set of complexes is denoted by C . In a reaction equation a substrate can also be a complex. In a single reaction equation the number of complexes is usually two, but when one considers a network of reaction equations we shall see that the number of complexes is more than two. So for reaction (3.1), S_1, \dots, S_k denote the substrates and S_{k+1}, \dots, S_n denote the products. Thus the set of species is $S = \{S_1, S_2, \dots, S_n\}$. In this reaction equation $S_1 + \dots + S_k$ and $S_{k+1} + \dots + S_n$ are the two complexes, so the set of complexes is $C = \{S_1 + \dots + S_k, S_{k+1} + \dots + S_n\}$, with $m = 2$.

The stoichiometry of a biochemical reaction and a biochemical reaction network is useful for the construction of a mathematical model. It is also an essential characteristic of biochemical reaction networks. The stoichiometry is the proportion of molecularities with which the substrates and products react, so the amount of molecules of products and substrates in the reaction. The signs of the stoichiometric coefficients depend on the direction of the reaction. The chemicals on the left-hand side of a reaction equation are the reactants. The stoichiometric coefficients for these substrates have a negative sign [13]. In reaction (3.1), S_1, \dots, S_k , have stoichiometric coefficient -1 , for the forward reaction, because these substrates are consumed by the reactions, and the products S_{k+1}, \dots, S_n all have stoichiometric coefficient 1 , for the forward reaction equation. For the backward reaction equation S_1, \dots, S_k , have stoichiometric coefficient 1 , and S_{k+1}, \dots, S_n have stoichiometric coefficient -1 .

For a network with m complexes and n chemical species, a set of m column vectors in \mathbb{R}^n is introduced, called complex vectors. The entries of the column vectors are the contributions of the species in the complexes. The column vectors are denoted by $b_1, b_2 \dots b_m$, the ordering of the numbering of the complexes is not important. Usually an ordering follows directly from the

network. Denote by b_{ij} the contribution coefficient of the j th species in the i th complex is meant. So this is the j th species of the i th complex. Hence the coefficients within the various complexes are all nonnegative numbers. The complex vectors are dependent on the standard basis for \mathbb{R}^n , denoted by $\{e_1, e_2, \dots, e_n\}$. Here e_i is the vector with entry 1 at the i th place and with the other $n - 1$ entries zero. For reaction equation (3.1) the complex vectors are

$$\begin{aligned} b_1 &= e_1 + \dots + e_k, \\ b_2 &= e_{k+1} + \dots + e_n. \end{aligned}$$

Finally for each reaction of the network a stoichiometric reaction vector, y_i , $i = 1, \dots, r$, with r the number of reactions, is defined as the difference between both complex vectors, then can be considered on both sides of the specific reaction in the network. So $y_i = b_k - b_l$ means that in the corresponding reaction equation the l th complex is consumed and the k th complex is produced. So y_i contains the stoichiometric coefficients of the i th reaction. For example (3.1), the stoichiometric vectors are

$$\begin{aligned} y_1 &= b_2 - b_1 = (-1, \dots, -1(k), 1, \dots, 1(n))', \\ y_2 &= b_1 - b_2 = (1, \dots, 1(k), -1, \dots, -1(n))'. \end{aligned}$$

So one can see that the entries of the stoichiometric vector are exactly the stoichiometric coefficients [10].

Chemical reactions are often catalyzed by enzymes, and so is Glycolysis in *Trypanosoma brucei*. The enzymes bind to one or more of the reactants of the reaction that they catalyze. By doing this the enzyme lower the activation energy. This is the energy needed and by this the reaction rate becomes higher. Enzyme molecules can collide and bind quicker to the substrate molecules when the concentration of substrate molecules is higher. This is also the case when the temperature is higher, but there is a limit. When the temperature has passed this limit an enzyme becomes denatured and ineffective. There are also inhibitors for the chemical reaction. Competitive inhibitors bind to the same site as the substrate, so the substrate can not bind the enzyme. Noncompetitive inhibitors are molecules that bind to another site of the enzyme and reduce the rate of catalyzing the chemical reaction. Enzyme kinetics is the study of the reaction rate of a chemical reaction that is catalyzed by one or more enzymes. The following example is an example of a reaction equation of a chemical reaction catalyzed by enzymes.

Example 3.1



Here E denotes the enzyme, A the substrate and P the product of the chemical reaction. First a molecule of substrate A , binds to a binding site of the enzyme E . The result is a complex EA . Then the reaction $A \rightarrow P$ is catalyzed by the enzyme and the product P occurs. Actually this is not a single reaction equation, but one often writes

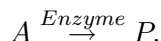

The number of species is four in this reaction equation, $n=4$, and the number of complexes is equal to three, $m=3$. Here the set of species is $S = \{E, A, EA, P\}$ and the set of complexes is $C = \{E + A, EA, E + P\}$. For this example the complex vectors in \mathbb{R}^4 are

$$\begin{aligned} b_1 &= (1, 1, 0, 0)', \\ b_2 &= (0, 0, 1, 0)', \\ b_3 &= (1, 0, 0, 1)'. \end{aligned}$$

The number of reaction equations, r , is four, so the stoichiometric vectors are

$$\begin{aligned} y_1 &= b_1 - b_2 = (1, 1, -1, 0)', \\ y_2 &= b_2 - b_1 = (-1, -1, 1, 0)', \\ y_3 &= b_3 - b_2 = (1, 0, -1, 1)', \\ y_4 &= b_2 - b_3 = (-1, 0, 1, -1)'. \end{aligned}$$

The following example is an example of a single reaction equation that is catalyzed by an enzyme. This chemical reaction is the first reaction that takes place in glycolysis.

Example 3.2

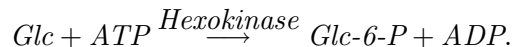

This reaction is the first reaction of glycolysis. In this reaction glucose has entered the cell and is phosphorylated by the enzyme hexokinase. Hexokinase transfers a phosphate group from ATP to glucose, yielding glucose 6-phosphate [6, p. 154].

In this example Glc , ATP , Glc-6-P and ADP denote species. In this reaction one molecule of glucose can react with one molecule of ATP to produce one molecule of glucose 6-phosphate and one molecule of ADP. In this reaction

Glucose and ATP are the substrates and glucose 6-phosphate and ADP the products. So Glc and ATP can represent respectively S_1 and S_2 in this reaction and Glc-6-P and ADP can represent P_1 and P_2 respectively. As one can check in this reaction $n = 4$ and $m = 2$. So then one has $S = \{S_1, S_2, P_1, P_2\}$ and $C = \{S_1 + S_2, P_1 + P_2\}$. By this the complex vectors of this example are

$$\begin{aligned} b_1 &= (1, 1, 0, 0)', \\ b_2 &= (0, 0, 1, 1)'. \end{aligned}$$

The stoichiometric vector for this reaction equation is

$$y_1 = b_2 - b_1 = (-1, -1, 1, 1)'.$$

The following two examples are examples of biochemical reaction networks. For these examples the set of species and the set of complexes is given, and also the complex vectors and the stoichiometric vectors are determined.

Example 3.3

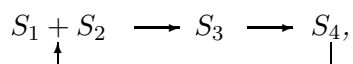

In this example S_3 is produced by the substrates S_1 and S_2 , while the product S_4 is produced by S_3 . From the product S_4 the substrates S_1 and S_2 can be produced by dissociation. In this biochemical reaction network $n=4$ and $m=3$. The sets of species and complexes are $S = \{S_1, S_2, S_3, S_4\}$ and $C = \{S_1 + S_2, S_3, S_4\}$. The complex vectors for this system are

$$\begin{aligned} b_1 &= (1, 1, 0, 0)', \\ b_2 &= (0, 0, 1, 0)', \\ b_3 &= (0, 0, 0, 1)'. \end{aligned}$$

For this network $r = 3$, and by this the stoichiometric vectors are

$$\begin{aligned} y_1 &= b_2 - b_1 = (-1, -1, 1, 0)', \\ y_2 &= b_3 - b_2 = (0, 0, -1, 1)', \\ y_3 &= b_1 - b_3 = (1, 1, 0, -1)'. \end{aligned}$$

Example 3.4

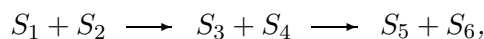

The substrates S_1 and S_2 react with each other to form two substrates S_3 and S_4 . From S_3 and S_4 the products S_5 and S_6 can be produced. In this example

the number of species is six, $n = 6$, and the number of complexes is 3, $m = 3$. Now the sets of species and complexes are $S = \{S_1, S_2, S_3, S_4, S_5, S_6\}$ and $C = \{S_1 + S_2, S_3 + S_4, S_5 + S_6\}$. The complex vectors for this example are

$$\begin{aligned} b_1 &= (1, 1, 0, 0, 0, 0)', \\ b_2 &= (0, 0, 1, 1, 0, 0)', \\ b_3 &= (0, 0, 0, 0, 1, 1)'. \end{aligned}$$

The stoichiometric vectors of this network are

$$\begin{aligned} y_1 &= b_2 - b_1 = (-1, -1, 1, 1, 0, 0)', \\ y_2 &= b_3 - b_2 = (0, 0, -1, -1, 1, 1)' \end{aligned}$$

Now that a reaction equation and a reaction system have been explained, the model of glycolysis in *Trypanosoma brucei* can be discussed.

3.2 Biochemical modelling of glycolysis in *Trypanosoma brucei*

An example of a biochemical reaction network is glycolysis of *Trypanosoma brucei*. First glycolysis shall be explained and then a biochemical reaction network is formulated. Barbara Bakker has presented a biochemical reaction network in her thesis, see [2, Ch. 2]. The biochemical model is developed by P. Michels and co-workers, from the Institute for Cellular Pathology, Université Catholique de Louvain, Brussels, Belgium.

Trypanosoma brucei causes the African sleeping disease. During part of its life cycle *Trypanosoma brucei* lives freely in the bloodstream and other extracellular fluids of its mammalian host. By bites of the tsetse fly *Trypanosoma brucei* can be transferred from one host to another host. *Trypanosoma brucei* has neither a Krebs cycle nor oxidative phosphorylation and it does not store carbohydrates. Thus in the bloodstream of the host, *Trypanosoma brucei* obtains its free energy, ATP, solely from glycolysis. During glycolysis, glucose is converted into pyruvate. Glycolysis in *Trypanosoma brucei* differs from glycolysis in other eukaryotes, such as humans. A part of the glycolysis of *Trypanosoma brucei* takes place in organelles called glycosomes, namely the conversion from glucose in 3-Phosphoglycerate (3-PGA). About 90 % of the proteins in the glycosomes consists of glycolytic enzymes, that is why the organelle is called glycosome. Glycosomes are evolutionary and functionally closely related to peroxisomes. The last two steps to pyruvate take place in the cytosol of the cell. First glucose has to be transported across the plasma membrane and the glycosomal membrane. When glucose enters the glycosome it is converted to 3-phosphoglycerate (3-PGA) in the glycosome

in several steps. After glucose is converted into 3-PGA, 3-PGA is converted into pyruvate in the cytosol.

Glucose enters the glycosome by first entering the cytosol from outside the cell by a glucose transporter ([6], [2]), after which it enters the glycosome by an other glucose transporter,



When glucose enters the glycosome it is phosphorylated into glucose 6-phosphate (Glc-6-P) by the enzyme Hexokinase. Hexokinase transfers a phosphate group from ATP to Glucose. The product, Glc-6-P is more chemically reactive than Glucose. The single phosphorylation reaction is the following:

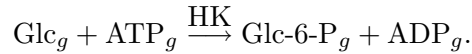

Then Glucose 6-phosphate is rearranged to convert it to Fructose 6-phosphate by the enzyme Glucosephosphate isomerase (PGI). This occurs in a reversible reaction, and gives the reaction equation



In the following step, another molecule of ATP is invested in glycolysis. An enzyme, Phosphofructokinase (PFK), transfers a phosphate group from ATP to the sugar Fructose 6-phosphate, to produce Fructose 1,6-bisphosphate by the following reaction:

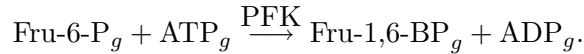

Now two molecules of ATP are invested in the glycolysis. Fructose 1,6-bisphosphate consists of two phosphate groups on both opposite ends. An enzyme, Fructose-1,6-bisphosphate aldolase (Fru-1,6-BP) cleaves the molecule of Fructose1,6-bisphosphate into Dihydroxyacetone phosphate (DHAP) and Glyceraldehyde-3-phosphate (GA-3-P), both three carbon sugars. So the reaction by Fru-1,6-BP aldolase, produce DHAP and GA-3-P from Fru-1,6-BP, in the following reversible reaction equation:

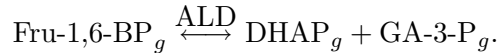

Triosephosphate isomerase (TIM) is an enzyme that catalyzes the reversible conversion between DHAP and GA-3-P,

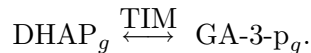

When only this single reaction can take place, this reaction reaches equilibrium. But in the glycosome this does not happen, because other enzymes use DHAP and GA-3-P as substrate.

From this point on two branches in glycolysis of *Trypanosoma brucei* are considered. Starting with DHAP, glycerol is produced after a few steps, and starting with GA-3-P, 3-PGA, and from this pyruvate is produced. In the reactions above, ATP consumption is considered, but in the following steps ATP is produced.

Now the enzyme Glyceraldehyde-3-phosphate dehydrogenase (GAPDH), catalyzes the reaction from GA-3-P to 1,3-Bisphosphoglycerate (1,3-BPGA). The sugar GA-3-P is oxidized by the transfer of electrons and H^+ to NAD^+ , forming NADH. The enzyme uses the energy released from the oxidation reaction, to attach a phosphate group to the oxidized substrate. The product 1,3-BPGA has a very-high potential energy. The following reaction equation is considered:

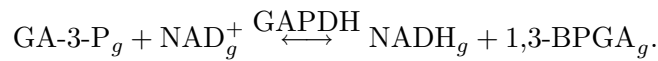

The enzyme Phosphoglycerate kinase (PGK) transfers the phosphate group, added by the reaction equation above, to ADP. So by this reaction ATP and 3-Phosphoglycerate are produced by release of one phosphate group from 1,3-BPGA. So the reaction equation is the following:

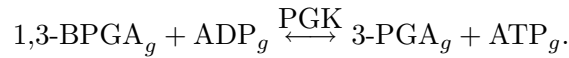

By this last reaction ADP is consumed and ATP is produced. After this 3-PGA is transported across the glycosomal membrane,

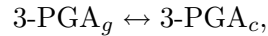

and by the enzyme Phosphoglycerate mutase (PGM) the phosphate group of 3-PGA is relocated. By this 3-PGA is converted in 2-Phosphoglycerate (2-PGA),



By the enzyme enolase (ENO) a double bond in 2-PGA is formed by extracting a water molecule, this produces Phosphoenolpyruvate (PEP),

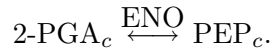

This reaction results in rearranging of the electrons, which makes the phosphate bond very unstable. By this the reaction from PEP into pyruvate can take place more easily. In this reaction the phosphate group from PEP is transferred to ADP by Pyruvate kinase (PYK). So ATP is produced from ADP and pyruvate is produced from PEP. The reaction equation is as follows:



Finally pyruvate crosses the cell membrane by a Pyruvate transporter,

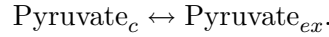

So far in the glycolyse there are two molecules of ATP used and two molecules of ATP produced.

In the other branch the NADH that is produced in the glycosomes by glyceraldehyde-3-phosphate dehydrogenase (GAPDH) is used, in the glycosome, to reduce dihydroxyacetone phosphate (DHAP) to glycerol 3-phosphate (Gly-3-P),



After this Gly-3-P is reoxidized by oxygen by an enzyme glycerol-3-phosphate oxidase (GPO), in the mitochondria. This reoxidation reaction produces H_2O ,



Before the reaction above can take place, first Gly-3-P has to cross the glycosomal membrane, by a transporter. After Gly-3-P is reoxidated in DHAP, DHAP has to across the glycosomal membrane by a transporter.

Under anaerobic conditions a phosphate group of Gly-3-P is added to ADP by Glycerol kinase (GK), by a reversible reaction. Then Gly-3-P is converted into glycerol by Glycerol kinase and a molecule of ATP is produced,



After this glycerol can cross the glycosomal- and the cell membrane.

In the cytosol also the following reaction took place by ATP utilisation:



All the individual reactions of glycolysis are considered now. When the reaction equations are taken together the complete system of glycolysis in *Trypanosoma brucei* can be considered. The system consists of biochemical reactions. In [2], B. Bakker has composed the system, called the reaction scheme of the model of glycolysis in the bloodstream of *Trypanosoma brucei*.

In the glycolysis of *Trypanosoma brucei* two molecules of ATP are consumed and three molecules of ATP are produced. Thus starting with one molecule of glucose there is a netto ATP production of one molecule ATP. The netto ATP production only takes place in the cytosol and neither in the glycosome nor in the mitochondrion. In the glycosome the consumption of ATP by hexokinase and by phosphofructokinase is balanced by the production of ATP by phosphoglycerate kinase. In the cytosol there is net glycolytic ATP production by pyruvate kinase.

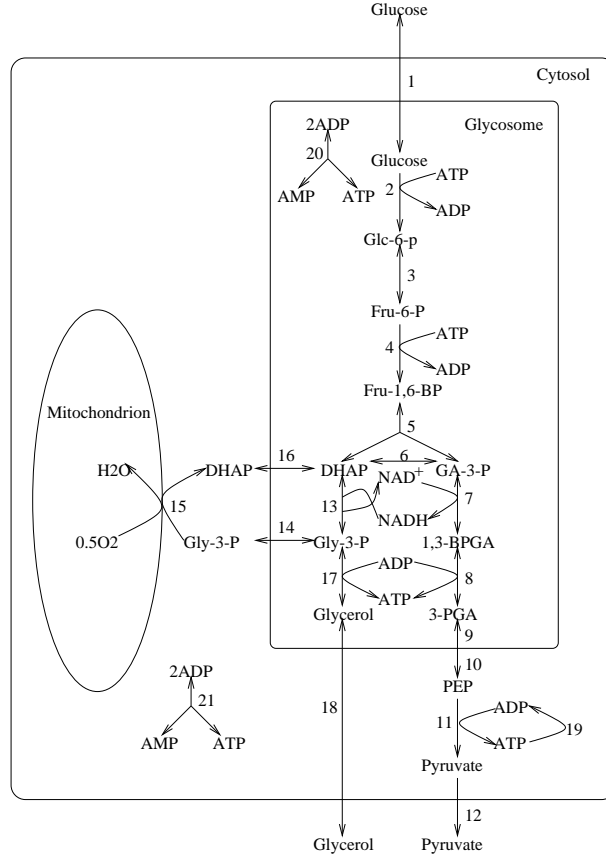
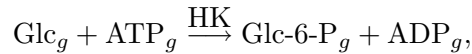

Figure 3.1: The reaction scheme of the model of glycolysis in bloodstream form *T. brucei*.
From Theses Dr. B. M. Bakker.

For this example 32 of the in total 39 different species, S_1, \dots, S_{37} , are considered. The number of complexes for this example is equal to 42. The species Glc_{ex} , Glc_c , and Glc_g stand for the species that occur when glucose enters first the cell and after this the glycosome by glucose transporters. In this case the complexes are the same as the species. For the reaction



the species are respectively Glc_g , ATP_g , $Glc-6-P_g$ and ADP_g . In this reaction the complexes are $Glc_g + ATP_g$, and $Glc-6-P_g + ADP_g$. So when all reaction equations are considered one finds in total 32 different species and 42 different complexes. In the appendix one can find all the reaction equations for this example, the list of species and complexes, and the set of species and complexes. With the help of the reaction equations and the complexes that are considered in these equations, reaction vectors can be found. For the transport of glucose across the cell- and the glycosomal membrane the reaction vectors are $y_1 = e_{38} - e_2$, $y_2 = e_2 - e_{38}$, $y_3 = e_1 - e_{38}$, and $y_4 = e_{38} - e_1$. For example for the reaction equation above the reaction

vector is, $y_5 = e_7 + e_3 - e_2 + e_6$. This is true because S_6 and S_2 are consumed and S_7 and S_3 are produced in this reaction.

3.3 Michaelis-Menten Reaction Kinetics

Under constant temperature and pressure, the direction in which a reaction may occur is determined by the change in the Gibbs free energy, G , [16]. The Gibbs free energy is defined as

$$\Delta G = \Delta G^{o'} + RT \ln \frac{[S]}{[P]},$$

with R the gas constant, T the temperature, $[S]$ the substrate concentration, and $[P]$ the product concentration. When the Gibbs free energy is negative the process may proceed in the forward direction, the substrate is converted into the product. When the Gibbs free energy is positive the reaction will proceed backwards, the product is converted into the substrate. When the Gibbs free energy is equal to zero there is no net forward and backward reaction, so the reaction is in equilibrium. In other words, when the concentration of substrate and product have their equilibrium values, $\Delta G = 0$. Then one can find for the equilibrium constant, $K_{eq} = \frac{[P]_{eq}}{[S]_{eq}}$ the following:

$$K_{eq} = e^{-\frac{\Delta G^{o'}}{RT}}.$$

The Gibbs free energy determines the direction of a reaction, but it does not determine the rate of a reaction. The rate of a reaction equation depends on the specific reaction kinetics. Biochemical reaction kinetic is based on the idea that the rate can be expressed as unique function of the concentrations of all species that occur in the reaction. Usually reaction networks are dependent on the availability of enzymes, so the reaction rates also depends on the enzyme concentrations [16].

The reaction kinetic that is used for most rate equations in the model of glycolysis of *Trypanosoma brucei* is Michaelis-Menten reaction kinetics. So it is useful to have some knowledge of this reaction kinetics to understand the rate equations considered in the section on mathematical modelling. The Michaelis-Menten reaction kinetics was first described by Leonor Michaelis (1875-1949) and Maud Leonora Menten (1879-1960). Michaelis and Menten showed that this theory could work accurately for their results, because of the nature of their experiments.

The reaction rate depends on the type of enzyme that catalyzes the reaction. Some enzymes are for example a much more effective catalyst for one of the directions of the reaction then for the other direction. The rate also

depends for example on the availability of inhibiting substrates or inhibiting products. So depending on such factors a rate equation can be determined. With the help of experiments one can find which type of rate equation has to be considered for a specific reaction. During the experiments one can find the curve that belongs to the rate of a reaction equation. With the help of this curve one can find the type of rate equation that belongs to the reaction equation. In this chapter general types of rate equations and specific rate equations that occur in glycolysis of *Trypanosoma brucei* are considered.

First Michaelis-Menten equations for one substrate and one product and then the Michaelis-Menten equations for a two substrate two product mixture are considered. For the Michaelis-Menten equations for one substrate first an irreversible reaction and afterwards a reversible reaction is treated. Subsequently, product inhibition and cooperativity are discussed. After this Michaelis-Menten equations for two substrates are treated, including product inhibition.

3.3.1 Michaelis-Menten Type Equation for One Substrate

First the rate equation for a reaction in which one substrate reacts with an enzyme as catalyst to form one product is considered. There are two cases that are considered, the reversible case and the irreversible case.

For the following rate equation there is assumed to be no reverse reaction from P to ES, the ES-complex is assumed to be in steady state and the amount of enzyme-bound S, $[ES]$ is assumed to be negligible. So the rate equation of



is

$$r = \frac{V^+ \frac{[S]}{K_s}}{1 + \frac{[S]}{K_s}}$$

In this equation V^+ is the maximal rate of the reaction when the substrate $[S]$ is increased, and the Michaelis constant K_s is the concentration of S where the rate is exactly half of V^+ .

The rate equation derived for the reversible reaction



is

$$r = \frac{V^+ \frac{S}{K_s} - V^- \frac{P}{K_p}}{1 + \frac{S}{K_s} + \frac{P}{K_p}}$$

Here V^+ is the maximal rate of the forward reaction and V^- is the maximal rate of the backward reaction.

Now first the Michaelis-Menten equation is derived for the irreversible reaction, after this the Michaelis-Menten equation for the reversible reaction is derived.

Irreversible Michaelis-Menten Mechanism

The reaction scheme to be considered first is:



The assumption on the reversible first step of this reaction is that it is fast enough to be represented by an equilibrium constant, namely $K_s = \frac{es}{x}$, with e the concentration of free enzyme, $[E]$, s the concentration of the substrate, $[S]$, and with x the concentration of the intermediate substrate $[ES]$. The free enzyme and substrate are not directly measurable. Because of this restrictions they have to be expressed in terms of the initial concentrations e_0 and s_0 , which are measurable. The stoichiometric relations $e_0 = e + x$ and $s_0 = s + x$ are used to determine the concentrations e and s . So the intermediate concentration x cannot be greater than e_0 , so when s_0 is much larger than e_0 it is also much larger than x . Hence in that case s_0 can be estimated by s . Now the following expression for x is considered:

$$x = \frac{es}{K_s} = \frac{(e_0 - x)s}{K_s} \Rightarrow x = \frac{e_0}{\left(\frac{K_s}{s}\right) + 1}.$$

The second step in the reaction is the reaction from the intermediate product, ES , to the free enzyme and the product, P , $ES \rightarrow E + P$. This is a first-order reaction, with a rate constant, defined as k_2 . Then, when v is the rate of this reaction,

$$r = k_2x = \frac{k_2e_0}{\left(\frac{K_s}{s}\right) + 1} = \frac{k_2e_0 \frac{s}{K_s}}{1 + \frac{s}{K_s}}.$$

Now the first step is not to be assumed in equilibrium, so

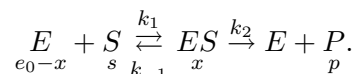

Briggs and Haldane (1925) determined a more general method to derive the rate equation. This leads to the following rate equation for the intermediate concentration, x :

$$\frac{dx}{dt} = k_1(e_0 - x)s - k_{-1}x - k_2x.$$

This equation is in steady state when $\frac{dx}{dt} = 0$, so then x is equal to

$$x = \frac{k_1 e_0 s}{k_{-1} + k_2 + k_1 s}.$$

Now the rate equation for the second step can be derived:

$$r = k_2 x \Rightarrow r = \frac{k_2 e_0 s}{\frac{k_{-1} + k_2}{k_1} + s} = \frac{V^+ s}{K_s + s} = \frac{V^+ \frac{S}{K_s}}{1 + \frac{S}{K_s}},$$

with $V^+ = k_2$, the maximal rate and $K_s = \frac{k_{-1} + k_2}{k_1}$, the Michaelis-Menten constant. This equation is called the Michaelis-Menten equation and is the fundamental equation of enzyme kinetics.

The curve defined by the Michaelis-Menten rate equation is a hyperbola through the origin.

Michaelis-Menten rate curve

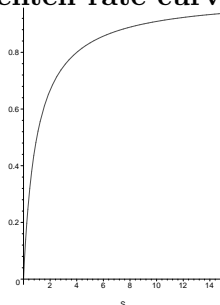

The asymptotes of this curve are $s = -K_s$ and $r = V^+$. When s small, the the denominator is close to K_s , then r close to $\frac{V^+ s}{K_s}$. So r is proportional to s . When s is equal to K_s , the rate equation for r is equal to

$$r \approx \frac{V^+ s}{2s} = \frac{1}{2} V^+.$$

In these conditions the rate is half of its limiting value, V^+ , and K_s can be defined as the concentration at which $r = 0.5V^+$. When the concentration s is very large, K_s can be neglected in comparison with s and the rate equation is approximately equal to V^+ ,

$$r \approx V^+.$$

Reversible Michaelis-Menten Mechanism

Most of the reactions that are important in biochemistry are reversible. This means that significant amounts of substrate and product are available in the

reaction mixture, when it reaches equilibrium. Now the following reversible reaction equation is considered:

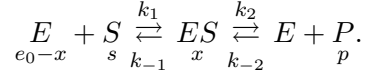

The rate equation for the intermediate product ES is:

$$\frac{dx}{dt} = (e_0 - x)sk_1 - xk_{-1} + (e_0 - x)pk_{-2} - k_2x.$$

When the reaction is in steady state, this rate equation is equal to zero. Solving for x one finds:

$$x = \frac{k_1e_0s + k_{-2}(e_0 - x)p}{k_{-1} + k_2 + k_1s + k_{-2}p}.$$

To determine the rate equation r for the production of P both the forward and the backward reaction are included, because of the reversibility. The net rate of release of P is determined by subtracting the rate at which it is consumed in the reaction $E + P \rightarrow ES$ from the rate at which it is released in the reaction $ES \rightarrow E + P$. The net rate is equal to

$$\begin{aligned} r &= k_2x - k_{-2}(e_0 - x)p \\ &= -k_{-2}e_0p + x(k_2 + k_{-2}p) \\ &= -k_{-2}e_0p + \frac{k_1e_0s + k_{-2}e_0p}{k_{-1} + k_2 + k_1s + k_{-2}p}(k_2 + k_{-2}p) \\ &= \frac{-k_{-1}k_{-2}e_0p - k_2k_{-2}e_0p - k_1k_{-2}e_0sp - k_{-2}^2e_0p^2}{k_{-1} + k_2 + k_1s + k_{-2}p} + \\ &\quad \frac{k_2k_1e_0s + k_2k_{-2}e_0p + k_1k_{-2}e_0sp + k_{-2}^2e_0p^2}{k_{-1} + k_2 + k_1s + k_{-2}p} \\ &= \frac{k_2k_1e_0s - k_{-1}k_{-2}e_0p}{k_{-1} + k_2 + k_1s + k_{-2}p}. \end{aligned}$$

When it is assumed that $p = 0$ the same equation as in the irreversible case is obtained, except that s should be replaced by s_0 , because only at $t = 0$ one can put $p = 0$. When s is assumed to be 0, the above equation for the rate r is equal to

$$r = \frac{-k_{-1}k_{-2}e_0p}{k_{-1} + k_2 + k_{-2}p}.$$

In this equation the rate has a negative sign, because the rate is defined as the rate of release of P .

The equation for r can be written in Michaelis-Menten form:

$$\begin{aligned} r &= \frac{k_2 k_1 e_0 s - k_{-1} k_{-2} e_0 p}{k_{-1} + k_2 + k_1 s + k_{-2} p} \\ &= \frac{V^+ \frac{s}{K_s} - V^- \frac{p}{K_p}}{1 + \frac{s}{K_s} + \frac{p}{K_p}}, \end{aligned}$$

with $V^+ = \frac{k_2 k_1 e_0}{(k_{-1} + k_2)}$ and $K_s = \frac{k_1}{(k_{-1} + k_2)}$ for the forward reaction, and $V^- = \frac{k_{-1} k_{-2} e_0}{(k_{-1} + k_2)}$ and $K_p = \frac{k_{-2}}{(k_{-1} + k_2)}$ for the backward reaction.

The above equation can be considered as the general reversible form of the Michaelis-Menten equation, for one substrate, [7].

Competitive Product Inhibition

A substance that decreases the rate of an enzyme-catalysed reaction when it is present in the reaction mixture is called an inhibitor. Inhibition can take place in many different ways, and there are many different types of inhibitors. When an inhibitor is competitive, the substrate and the inhibitor compete for the same site.

When it is assumed that only one product is available in a reaction mixture, which is often not the case, the rate is assumed to be almost irreversible in the case of product inhibition. Actually, product inhibition is observable in many essentially irreversible reactions. In this case it is possible for the product P to bind to the binding side of the enzyme. The mechanism is as the two-step mechanism, only the first step is irreversible and the second is not

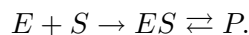

This phenomenon is not very likely as a general phenomenon. The three-step mechanism can also occur,

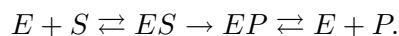

This mechanism is based on the case that inhibition can take place in an irreversible reaction if the chemical transformation of EP in ES cannot take place, so this transformation is irreversible. In this case the product causes the enzyme to stay as the EP complex, and by this it is unavailable for reacting with the substrate.

The numerator that refers to the reverse reaction is taken zero in the case of product inhibition, because the reaction is seen as being irreversible. When the reaction is only in forward direction the amount of product accumulates.

So the effect is adding more and more product, and this increases the denominator of the rate equation, and thus inhibits the forward reaction. So the following rate is obtained for competitive product inhibition:

$$r = \frac{V^+ \frac{s}{K_s}}{1 + \frac{s}{K_s} + \frac{p}{K_p}}.$$

So r only contains p in the denominator [7].

Cooperativity

Many enzymes that play an important role in metabolic regulation, respond very sensitive to changes in concentrations of metabolites. This is called cooperativity.

The degree of cooperativity of an enzyme can often be expressed by the following equation:

$$r = \frac{V^+ a^h}{K_{0.5}^h + a^h},$$

for some $h \in \mathbb{R}$. This equation is called the Hill equation, because it was published by Hill (1910). In this equation V^+ is still the limiting rate and $K_{0.5}$ defines the value of the substrate concentration s at which $r = 0.5V^+$. Hill regarded this equation as empirically and has no physical meaning for the exponent h , which is called the Hill coefficient [7].

3.3.2 Michaelis-Menten Type Equation for Two Substrates

Reactions of a single substrate and a single product are rare in biochemistry. Also in Glycolysis of *Trypanosoma brucei* most of the reactions, not all, are reactions of two substrates, with two products as its end product. So in this subsection the general reaction with two substrates and two products is used as a general example,

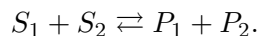

This example is the most common reaction type in biochemistry.

Almost all reactions with two substrates and two products are formally group transfer reactions. With the help of rewriting the general reaction one can see this. The reaction

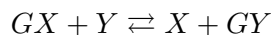

is considered, with S_1 is written as GX and S_2 written as Y . In this reaction a group G is transferred from GX to the molecule Y . This group

transfer can occur in different ways. Two types of group transfer mechanisms are ternary-complex mechanisms (random-order and compulsory-order) and substituted-enzyme mechanisms.

The ternary-complex mechanisms proceed by forming a complex $EGX \cdot Y$, this is called a ternary-complex. This complex contains the enzyme and the substrates in one complex. In the random-order ternary-complex mechanism GX as well as Y can bind to the enzyme E . So both complexes can occur as intermediate product. In the compulsory-order mechanism first GX binds to the enzyme E . In these two mechanisms the group G is transferred once.

Also the substituted-enzyme mechanism is a common important mechanism. The ternary-complex is impossible, because the binding sites for X and Y are the same or overlapping. In this mechanism it is possible for the substrate to bind to the wrong form of the enzyme. A consequence of this is substrate inhibition at high substrate concentrations. In this mechanism there is one order, so there is no random order. In this mechanism G is transferred twice, first from the substrate GX to the free enzyme E , then from the substituted enzyme EG to the substrate Y .

For the rate equations in the Glycolysis of *Trypanosoma brucei*, the enzymes that catalyze the reactions between two non-competing product-substrate couples (GAPDH, PGK, Glycerol-3-phosphate dehydrogenase (GDH) and GK) use the random-order ternary-complex mechanism. So in this section this mechanism is considered.

Random-Order Ternary-Complex Mechanism

The mechanism is called ternary-complex, because it contains the enzyme and both substrates in a single complex, $EGX \cdot Y$. In the random-order ternary-complex mechanism GX as well as Y can bind to the enzyme in a random order. So both EGX and EY can be intermediate product. When it happens that no binding site exists on the enzyme for one of the substrates until the other has bound, then the order of binding is called compulsory order. When all substrates and products are considered, four different orders are possible. But the reverse reaction is expected to be analogous to the forward reaction, so the second product is then analogue to the first substrate. Thus only two of the four possibilities are very likely.

Random-order ternary-complex mechanism, [4]

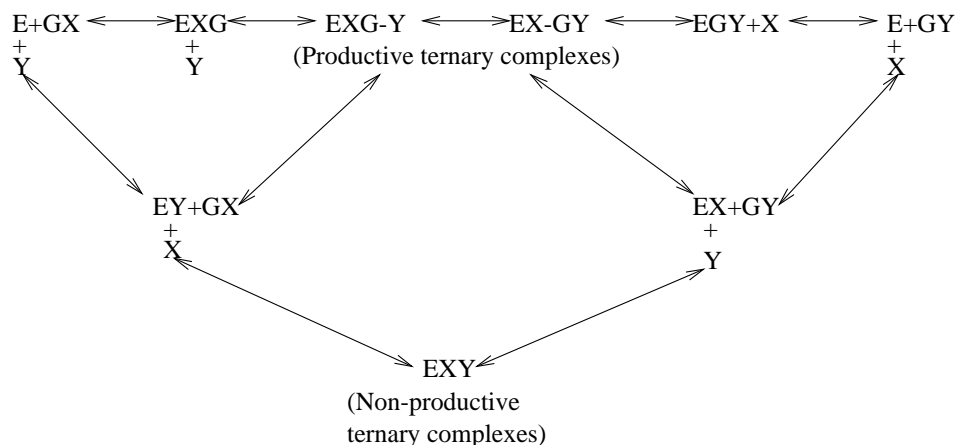

The complex EXY does not always occur in the random-order mechanism, but it can normally be expected to exist. When the group G is not too big $EXG \cdot GY$ can result from binding of GY to EGX or of GX to EGY . This is less likely than EXY .

To obtain the rate equation for this mechanism the King-Altman method is used [7, Ch. 4]. Considering all reaction equations that occur one can find the rate equation, in which the product P_1 , which is X , is produced systematically. For a small system it is relatively easy to compute the rate equation, but already for a system like the random-order ternary-complex mechanism the possibilities of the method become large and the rate equation is difficult to obtain by hand.

For the glycolysis of *Trypanosoma brucei* all steps of the enzymes that behave with this mechanism, apart from the step from $EGX \cdot Y$ to EXY , are assumed to be in equilibrium. So by this assumption there are no squared terms in the rate equation. By using the King Altman method for the random-order ternary-complex kinetic for two non-competing product-substrate couples, the following rate equation is obtained:

$$r = V^+ \cdot \frac{\frac{S_1}{K_{S1}} \cdot \frac{S_2}{K_{S2}} - \frac{V^-}{V^+} \cdot \frac{P_1}{K_{P1}} \cdot \frac{P_2}{K_{P2}}}{\left(1 + \frac{S_1}{K_{S1}} + \frac{P_1}{K_{P1}}\right) \cdot \left(1 + \frac{S_2}{K_{S2}} + \frac{P_2}{K_{P2}}\right)}$$

Product inhibition by one of the products

In the glycolysis of *Trypanosoma brucei* for the enzyme HK there is competitive product inhibition by ADP, but the other product Glc-6-P has no effect on the rate.

When only one of the products is added to a reaction mixture, the term in the numerator that refers to the reverse reaction must be zero. The effect of adding product is an increase in the denominator of the rate equation, and thus inhibiting the forward reaction. So when there is product inhibition by one of the two products in the mixture, the rate equation is the following:

$$r = V^+ \cdot \frac{\frac{S_1}{K_{S1}} \cdot \frac{S_2}{K_{S2}}}{\left(1 + \frac{S_1}{K_{S1}} + \frac{P_1}{K_{P1}}\right) \cdot \left(1 + \frac{S_2}{K_{S2}}\right)}.$$

So now some forms of Michaelis-Menten equations are described that can be found in the glycolysis of *Trypanosoma brucei*. It is useful to have some knowledge of this type of reaction kinetic to understand the rate equations for *Trypanosoma brucei*.

3.4 Procedure of Mathematical Modelling

To understand biochemical reaction networks, researchers try to make mathematical models of biochemical reaction networks, from which one can extract relations. From chemical experiments it is possible to derive a model in the form of a biochemical reaction network. For biochemical reaction networks often there can be defined algebraical relations, such as moiety-conservation relations and equilibrium relations and relations for the pools in the reaction network.

A way to make a mathematical model is to formulate a system of differential equations of the reaction system. To do this one first needs the rate equations of a given network of reaction equations. The rate equations consist of input variables, which are often constant, and of state variables. The output variables are the variables in which we are interested. These variables are determined by a function of the state variables, the input variables, and the time.

The mathematical model that will be formulated is called a dynamical system. Dynamical systems are studied in mathematical system theory, and consist usually of a set of differential equations. This set of differential equations is a function of t , $x(t)$ and $u(t)$, and can be either a linear or a non-linear function. These systems consist of a collection of variables and their interactions over time. Such systems may be schematically described by the following figure:

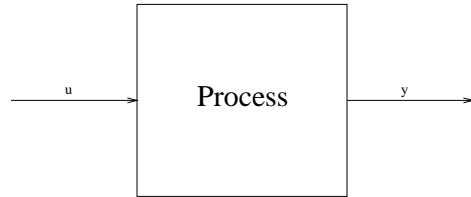

The box is called the process and stands for the way the outputs depend on the inputs, for example by a set of differential equations.

For input-output systems there are two types of variables, namely input variables and output variables. The input variables can be chosen freely and the output variables are determined by the input and the state. The input variables are called exogenous variables in system theory and output variables are called endogenous variables. In many applications one starts by isolating a part of the real world and calls this the system. In this case the input variables are the variables from the environment that influence the system, and the output variables describe the effects of the input variables.

When the input depends on the time, $t \in [t_0, \infty)$, the whole system depends on time and by this there is no memory. The systems that are considered most are systems that do not depend on time. Often the input is constant.

To derive the relation between input and output variables, some extra variables can be derived. These variables are called state variables. State variables summarize all the information of the past to determine the future of those state variables. States are called auxiliary variables. The state of biochemical system is uniquely determined by all concentrations in the system and through the parameters that are constant in time. The output of a system is a function of the time t the state $x(t)$, and the input $u(t)$, which is mostly constant.

The rate equations of biochemical reaction networks also depend on the state of the system. With the help of the network one can define the states of the system. In the case of a biochemical reaction network these are the concentrations of the species that occur in the reactions. So a list of states can be made. The states of the system have to be positive, since they are concentrations.

The rate equations depend on the specific reaction kinetics. Chemical and biochemical reaction kinetics is based on the idea that the reaction rate can be written as a unique function of the concentrations of all species that occur in the reactions. The rate equations are usually experimentally determined. Usually reaction networks are dependent on the availability of enzymes, then the rate equations depend on the enzyme concentrations. With the help of the biochemical reaction networks a list of enzyme concentrations can be made. The rate equations for the model of *Trypanosoma brucei* are based on Michaelis-Menten kinetics. This is considered in Section 3.3.

The vector of input variables at time t , is denoted by $u = (u_1(t), \dots, u_k(t))^T \in \mathbb{R}^k$, with $k \in \mathbb{Z}_+$. The vector of states of the system is denoted by $x = (x_1(t), \dots, x_n(t)) \in \mathbb{R}_+^n$, with $n \in \mathbb{Z}_+$, and $y(t) = (y_1(t), \dots, y_p(t))^T$ is the vector of output variables, with $p \in \mathbb{Z}_+$. These output variables are the variables in which we are interested. The output can be equal to one or more of the state variables.

Now a continuous-time dynamical system can be defined as follows:

Definition 3.5 [28, p.40, (2.41)]

A continuous-time positive (dynamical) system is a dynamical system in the form of a differential equation and output variable,

$$\begin{aligned} \frac{dx}{dt} &= f(t, x(t), u(t)), \\ x(t_0) &= x_0, \text{ the state at initial time } t_0, \\ y(t) &= h(t, x(t), u(t)). \end{aligned}$$

For this system

$$\begin{aligned} T &= [t_0, \infty) \subset \mathbb{R}, \text{ the time index set,} \\ X &= \mathbb{R}_+^n, \text{ the state set,} \\ U &= \mathbb{R}_+^k, \text{ the input set,} \\ Y &= \mathbb{R}_+^p, \text{ the output set,} \end{aligned}$$

$$n, k, p \in \mathbb{Z}_+, f : T \times X \times U \rightarrow TX \quad h : T \times X \times U \rightarrow Y.$$

The functions f and h can be linear or nonlinear functions such that, if $x_0 \in X$ and $u : T \rightarrow U$ are given then there exist a state and output trajectory: $x : T \rightarrow X$ and $y : T \rightarrow Y$, both taking values in a positive vector space over the positive real numbers.

So the change of the state x is a function of t , $x(t)$ and $u(t)$ with the state at initial time equal to x_0 . Also the output is a function of t , $x(t)$ and $u(t)$.

For biochemical reaction networks often there can be defined algebraical relations. One reason are moiety-conservation relations. A system for reaction networks in a cell often contains moiety conservation relations. These are subgroups of metabolites which are conserved during the evolution of a network. The sum of the concentrations of metabolites in the mass conservation relation is constant. For example the total concentration of the NAD is conserved throughout the time. So the sum of NAD and NADH is constant. Another example of a conserved moiety is the conservation of adenine nucleotide, this means that the sum of ATP, ADP and AMP is constant during the evolution of the system. The sum of these metabolites

is thus a parameter of the pathway. With the help of the stoichiometric scheme one can derive the moiety conservation relations. Other reasons of algebraic equations are equilibrium reactions and metabolite pools. Some of the reactions in the reaction network are considered to be in equilibrium. For these reaction equilibrium equations can be formulated. The substrates and products of an equilibrium reaction can be seen as a single metabolite pool [2]. So pool relations can be formulated.

The function for the change of the states for a rational positive system for a cell reaction network depend on the rate equations, which depend on the states, $x(t)$ and x_{ex} and the input functions $u(t)$. Here x_{ex} is the vector of external concentrations. The change of state i is the sum of all the rates with which x_i is produced times the input times the stoichiometric matrix from x_j minus the sum of the rates times the input times the stoichiometric matrix with which x_i is consumed to produce x_j . The rate equations for a rational positive system for a cell reaction network is the quotient of two polynomials, $p_j = p_j^+ - p_j^-$ and q .

The output is a function of the states and the input functions. For a rational positive system for a cell reaction network this is a matrix H times the rate equations times the input functions.

Now a continuous-time positive system for a cell reaction network can be defined by the following definition.

Definition 3.6 [28, p.40, (2.41)]

A rational positive system for a cell reaction network is defined by the following differential equation,

$$\frac{dx}{dt} = \sum_{h=1}^n \sum_{k=1}^n n(b_i - b_j) r_{hk}(x(t)) u_{hk}(t), \quad x(t_0) = x_0,$$

with output

$$y(t) = H \text{Diag}(r(x(t), x_{ex})) u(t).$$

The differential equation per component $i \in \mathbb{Z}_n$ is

$$\begin{aligned} \frac{dx_i}{dt} &= \sum_{h=1}^n \sum_{k=1}^n n(b_i - b_j) r_{hki}(x(t)) u_{hki}(t) \\ &= \sum_{j=1}^m \left[\frac{p_j^+(x(t), x_{ex})}{q_j(x(t), x_{ex})} - \frac{p_j^-(x(t), x_{ex})}{q_j(x(t), x_{ex})} \right] u_j(t) (b_i - b_j) \\ &= f_i(x(t), x_{ex}, u(t)), \quad x_i(t_0) = x_{i,0}. \end{aligned}$$

with output

$$y_i(t) = \sum_{j=1}^m h_{ij} r_j(x(t), x_{ex}) u_j(t)$$

For this differential equation

$$\begin{aligned} T &= [t_0, \infty), \text{ the time index set,} \\ X &= \mathbb{R}_+^n, \text{ the state set,} \\ X_{ex} &= \mathbb{R}_+^{n_{ex}}, \text{ the set of external concentrations,} \\ U &= \mathbb{R}_+^m, \text{ the input set of enzyme concentrations,} \\ B &\in \mathbb{Z}^{n \times m}, \text{ the stoichiometric matrix,} \\ b_h, b_k &\in \mathbb{N}^n = \{0, 1, 2, \dots\} \\ H &\in \mathbb{N}^{n_y \times m}, \\ &\text{the matrix that determines the outputs from the rate equations,} \end{aligned}$$

with $n, m \in \mathbb{Z}_+$, $n_{ex}, n_y \in \mathbb{N}$, and

$$\begin{aligned} u &: T \rightarrow U, && \text{an input function,} \\ r &: X \times X_{ex} \rightarrow \mathbb{R}^m, && \forall j \in \mathbb{Z}_m, \text{ the rate equation,} \\ r_j(x, x_{ex}) &= \frac{p_j^+(x, x_{ex})}{q_j(x, x_{ex})} - \frac{p_j^-(x, x_{ex})}{q_j(x, x_{ex})}, \\ &&& \frac{p_j^+(x, x_{ex})}{q_j(x, x_{ex})}, \frac{p_j^-(x, x_{ex})}{q_j(x, x_{ex})} \in \mathbb{R}_{+,s}(x, x_{ex}), \\ \text{Diag}(r(x, x_{ex})) &= \text{Diag}(r_1(x, x_{ex}), \dots, (r_m(x, x_{ex}))) \in \mathbb{R}^{m \times m}, \\ &&& \text{diagonal matrix,} \\ y &: T \rightarrow \mathbb{R}^{n_y}, && \text{where } y \text{ represents the outflow of the system.} \end{aligned}$$

The chemical reaction networks inside a cell can be very large. Although it is in principal possible to model all reactions it is not yet realistic to analyze such a network. One often tries to understand pieces of the network, such that by means of this one can understand the whole network of chemical reaction equations. Model reduction is an other possible solution for this problem.

In the following section mathematical modelling of glycolysis in *Trypanosoma brucei* is considered as an example of mathematical modelling.

3.5 Mathematical Modelling of Glycolysis in *Trypanosoma Brucei*

In this section the mathematical model of *Trypanosoma brucei* is considered. A mathematical model was made by Barbara Bakker [2], and contains a set of differential equations, which depends on the rates which are also contained in the thesis, and contains moiety equations, equilibrium equations, and pools. These equations concern enzyme concentrations, states and outputs and constant variables.

First, this model will be translated into a model with mathematical notations, as used in dynamical system theory. Then a dynamical system is available that consist of differential equations and algebraical equations. However, more state variables are available then the number of differential equations.

For the model of glycolysis of *Trypanosoma brucei* it is possible to reduce the number of states in the set of differential equations, because of the available algebraic relations between the states. After doing this, the system of differential equations is reduced and contains only the state, for which differential equations are available. This is done by reduction of state variables. So after reduction of state variables the system is changed, but we shall see by solving the system numerically in Section 4.4 that the solution of the system is the same.

It is not completely clear if the system is easier to solve after reduction of state variables. Actually when the states of the differential equations are found, the other states can be easily determined with the help of the algebraic equations from the known state variables. This holds for the model of glycolysis of *Trypanosoma brucei*, but does not hold for every dynamical system for a cell reaction network. The system cannot always be reduced to a set of k differential equations in k unknowns.

In this section also the output variables are defined, these are the variables that are produced, but not consumed. Actually usually the output variables are defined as the output variables of interest. The rate equations for the specific reaction equations are used to find the output variables. The output variables depend on the input variables and the state variables.

In this section methods are discussed and a few results are given. Most of the results are given in the appendix.

3.5.1 Dynamical system

In this subsection the model of glycolysis in *Trypanosoma brucei* of Barbara Bakker is translated into a model with mathematical notations, as used in

system theory. In the first place some notations, definitions and terminology will be discussed and the enzyme concentrations and the states are derived for the model.

Below the rate equations of all the reactions that take place in the reaction network are considered. The rate equations depend on the states and the input variables. Most of the reactions are catalyzed by enzymes and follow one of the forms of the Michaelis-Menten kinetic, discussed in Section 3.3. So the rate equations of most of the reaction equations are or the form of one of the Michaelis-Menten equations.

After formulating the rate equations the differential equations are stated, such as determined by Barbara Bakker. Not for all state variables a differential equation is presented. After giving the differential equations, moiety-conservation relations, pools and equations for fast dynamics are presented. Finally extra algebraic equations are determined by using the moiety-conservation relations, pools and fast dynamics.

In Appendix A.3.1 one can find a short list of notations that are used in the state variables and in the constants. These are notations for the total concentrations, enzyme concentrations, and external concentrations. But also notations for in which compartment a state concentration is considered, as well as notations for the state variables and the input variables are given.

Input variables

The model for glycolysis in *Trypanosoma brucei* consists of enzyme concentrations, which catalyze the reactions in the biochemical reaction network. In the Michaelis Menten rate equations V^+ and V^- contain the enzyme concentration. Now the input variables $u_i, i = 1, \dots, 21$ will be introduced, which are used to adjust the enzyme concentrations, used for control analysis in Chapter 5, or to adjust membrane transport.

The rate equations are all multiplied by the u_i for the enzyme that catalyzes the reaction. But also for example for membrane transport that is not catalyzed by any enzyme. For example, glucose transport which is facilitated by a diffusion carrier. So usually these $u_i, i = 1, \dots, 21$ are defined as 1. Only when we want to adjust particular concentrations, those values will differ from 1. The input variables are given in the form of a vector u ,

$$u = \begin{pmatrix} u_1 \\ \vdots \\ u_{21} \end{pmatrix} \in \mathbb{R}_+^{N_{en}} = \mathbb{R}_+^{21}, N_{en} = 21.$$

From the glycolysis of *Trypanosoma brucei*, 21 input variables can be obtained. For example u_1 is the input variable for the transport of glucose across the plasma membrane and is coupled to the first rate equation, r_1 ,

for the glucose transport across the plasma membrane. Also, u_7 is the input variable for GAPDH and is coupled to the seventh rate equation, r_7 . So the rate equations and the inputs are coupled to each other by having the same number as a subscript. Every reaction in the biochemical reaction network, that is not assumed to be in equilibrium, belongs to an input variable and a matching rate equation.

A list of input variables is given in the Appendix A.3.1, and a list of abbreviations is given in Appendix C.

State variables

The states of the biochemical reaction network for glycolysis in *Trypanosoma brucei* are the concentrations of the chemical substances, S_1, \dots, S_{39} , which are contained in the rate equations or the algebraical equations. In the model for glycolysis of *Trypanosoma brucei* only the concentrations of S_{38} and S_{39} are not contained in the rate equations or in the algebraic equations.

The states of the system are defined by a vector x ,

$$x = \begin{pmatrix} x_1 \\ \vdots \\ x_{37} \end{pmatrix} \in \mathbb{R}_+^{37}, \quad N = 37,$$

with x_i , $i = 1, \dots, 37$. The state x_i is the concentration of substance S_i . Actually we can say that the number of state variables of the biochemical reaction network is equal to $37 - 3 = 34$, because x_2 , x_{26} and x_{27} are excluded since they are external concentrations.

Glycolysis of *Trypanosoma brucei* takes place in the glycosome, which is a compartment within the cell. A number of states, 17 in total, are concentrations of substances in the glycosome. The substrate Fru-6-P is an example of a substance in the glycosome. Other concentrations will be in the cytosol, like 2-PGA. Substances such as ATP, ADP and AMP are found both in the glycosome and in the cytosol. Some substances are found in the mitochondrion, such as O_2 and H_2O . Glucose, glycerol and pyruvate outside the cell are defined as external state variables.

Several state variables are the same in every compartment. Then the concentration of that substance is a total concentration and is the same in the cytosol and the glycosome. For these states the overall concentration can be given. This holds for Gly-3-P, DHAP, and 3-PGA. In several algebraic equations the average concentrations over the glycosome and the cytosol is used. One shall see that this is the case for Triose-P and N.

Several of the chemical components can pass the cell membrane and by this move from one compartment to another compartment. State variables such as DHAP can cross the glycosomal membrane and for example the produced pyruvate can cross the cell membrane. Other substances, for example ATP,

The rate equations, which are formulated in [2] contain concentrations of chemical substances, and constant variables. The concentrations are the state variables x_i , $i = 1, \dots, 37$. The constants that are used in the rate equations have two indices, i and j , and are denoted by $c_{i,j}$, with $c_{i,j}$ the j -th constant of rate equation i . Here $i = 1, \dots, 19$, since the system consists of 19 rate equations in total. The index $j = 1, \dots, n$, $n \in \mathbb{N}$, depends on the amount of constants a rate equation contains, so n differs per rate equation. When $j = 1$, the constant V^+ is denoted almost always.

In this section the type of rate equations will be described and a few of them are given, to explain how the rate equations of Barbara Bakker are rewritten. The other rate equations can be found in Appendix A.3.2.

The first rate equation is for the transport of glucose across the cell- and the glycosomal membrane. First glucose enters the cytosol from outside the cell, by a glucose transporter. After this glucose will enter the glycosome by another glucose transporter. The carrier proteins, that span the membrane, bind the glucose and by this undergo conformation changes. The effect of these changes is carrying glucose across the membrane. After this the conformation of the protein is changed back in its original state. The glucose transport across the membrane is described according to a 4-state model for a diffusion carrier. It is found by experiments that the carrier is asymmetric. So the kinetics of the glucose transporters can be described by the rate equations for a asymmetric carrier.

The rate equation for glucose transport is

$$v_{\text{glucose transport}} = V^+ \frac{[\text{Glc}]_{\text{out}} - [\text{Glc}]_{\text{in}}}{K_{\text{Glc}} + [\text{Glc}]_{\text{out}} + [\text{Glc}]_{\text{in}} + \alpha [\text{Glc}]_{\text{out}} [\text{Glc}]_{\text{in}} / K_{\text{Glc}}}.$$

In this equation K_{Glc} is the Michaelis-Menten constant. Here α is a constant that depends on the relative mobility of the loaded and the unloaded carrier protein. The constants are experimentally obtained, all at 25 °C [2, p. 33]. When assuming symmetry of the carrier and from the fact that V_{max} was found twice as high for equilibrium exchange as for zero-trans influx, α was calculated to be 0,75 ([21], [2, p. 34]).

In this equation the states are the external glucose concentration and the intracellular glucose concentration, which is the glucose concentration in the glycosome. The rate equation is written in Michaelis-Menten form. The rate equation with the notation, which is used in this report is

$$r_1 = c_{1,1} \frac{c_{1,2}(x_2 - x_1)}{1 + x_2 c_{1,2} + x_1 c_{1,2} + c_{1,3} x_1 x_2 c_{1,2}^2},$$

with

$$\begin{aligned}
r_1 &= v_{\text{gltr}}, \\
x_2 &= [\text{Glc}]_{\text{ex}} = S_1, \\
x_1 &= [\text{Glc}]_g = P_1, \\
c_{1,1} &= V^+ = 106.2 \text{ nmol}(\text{min})^{-1}(\text{mg cell protein})^{-1}, \\
c_{1,2} &= \frac{1}{K_{1,1}} = \frac{1}{K_{\text{Glc}}} = \frac{1}{2}(\text{mM})^{-1}, \\
c_{1,3} &= \alpha = 0.75.
\end{aligned}$$

So v_{gltr} is denoted by r_1 . The states, glucose concentration in the glycosome and the external glucose concentration are denoted by, respectively, x_1 and x_2 . Further, $j = 1, 2, 3$ in this equation, so for the constants $c_{1,1}, c_{1,2}, c_{1,3}$ are obtained, with $c_{1,1} = V^+$, and $c_{1,3} = \alpha$. For the constants also the notation of [2] is denoted.

The second rate equation is the rate equation for the reaction that is catalyzed by the enzyme hexokinase. Glucose in the glycosome is phosphorylated into glucose 6-phosphate. The kinetics of HK can be described by a Michaelis-Menten type equation for two substrates, with competitive product inhibition by ADP. The second product glucose-6-phosphate has no effect on the rate. The rate equation is

$$v_{\text{HK}} = V^+ \frac{\frac{[\text{ATP}]_g}{K_{\text{ATP}}} \cdot \frac{[\text{Glc}]_{\text{in}}}{K_{\text{Glc}}}}{\left(1 + \frac{[\text{ATP}]_g}{K_{\text{ATP}}} + \frac{[\text{ADP}]_g}{K_{\text{ADP}}}\right) \cdot \left(1 + \frac{[\text{Glc}]_{\text{in}}}{K_{\text{Glc}}}\right)}.$$

Rewritten the following is obtained for r_2 :

$$r_2 = c_{2,1} \frac{c_{2,2} x_6 x_1 c_{2,3}}{(1 + x_6 c_{2,2} + x_7 c_{2,4})(1 + x_1 c_{2,3})},$$

with

$$\begin{aligned}
r_2 &= v_{\text{HK}}, \\
x_6 &= [\text{ATP}]_g = S_1, \\
x_1 &= [\text{Glc}]_g = S_2, \\
x_7 &= [\text{ADP}]_g = P_1, \\
x_3 &= [\text{Glc-6-P}]_g = P_2, \\
c_{2,1} &= V^+ = 625 \text{ nmol}(\text{min})^{-1}(\text{mg cell protein})^{-1}, \\
c_{2,2} &= \frac{1}{k_{2,6}} = \frac{1}{K_{\text{ATP}_g}} = \frac{1}{0.116} = 8.6207 \text{ (mM)}^{-1}, \\
c_{2,3} &= \frac{1}{k_{2,1}} = \frac{1}{K_{\text{Glc}_g}} = \frac{1}{0.1} = 10 \text{ (mM)}^{-1}, \\
c_{2,4} &= \frac{1}{k_{2,7}} = \frac{1}{K_{\text{ADP}_g}} = \frac{1}{0.126} = 7.9365 \text{ (mM)}^{-1}.
\end{aligned}$$

For this rate equation $v_2 = r_2$ and $j = 1, \dots, 4$, so four constants are considered. The first constant, $c_{1,1}$, denotes V^+ . The other three constants are

denoted for the inverses of the Michaelis-Menten constants K_{ATP_g} , K_{Glc_g} , and K_{ADP_g} . These constants are respectively $c_{2,2}$, $c_{2,3}$, and $c_{2,4}$. The equation involves the states x_6 , x_1 , x_7 , and x_3 .

The third reaction is the reaction, catalyzed by the enzyme PGI, from Glc-6-P to Fru-6-P. This reaction is a very fast reaction and is assumed to be in equilibrium. This is the same for the reactions 6, 9 and 10, which belong together, 20 and 21 which are respectively catalyzed by TIM, PGM, ENO and glycosomal AK. The kinetics of the transport of 3-PGA, Gly-3-P and DHAP are unknown, so these steps were assumed to be in equilibrium as well.

The fourth and the eleventh reaction rates involve a cooperative dependence on one of the concentrations. The fourth reaction is catalyzed by the enzyme PFK, this exhibits cooperative dependence of Fru-6-P. The eleventh reaction equation is catalyzed by PYK and the rate depends cooperatively on the concentration of PEP. The rate equation of the fourth reaction equation is

$$v_{\text{PFK}} = V^+ \frac{\left(\frac{[\text{Fru-6-P}]}{K_{\text{m,Fru6P}}}\right)^n \cdot \left(\frac{[\text{ATP}]}{K_{\text{m,ATP}}}\right)}{\left(1 + \left(\frac{[\text{Fru-6-P}]}{K_{\text{m,Fru6P}}}\right)^n\right) \cdot \left(1 + \frac{[\text{ATP}]}{K_{\text{m,ATP}}}\right)}$$

and this is rewritten as:

$$r_4 = c_{4,1} \frac{(c_{4,2}x_4)^n (c_{4,3}x_6)}{(1 + (c_{4,2}x_4)^n) (1 + c_{4,3}x_6)},$$

with

$$\begin{aligned} r_4 &= v_{\text{PFK}}, \\ x_4 &= [\text{Fru-6-P}]_g = S_1, \\ x_6 &= [\text{ATP}]_g = S_2, \\ x_5 &= [\text{Fru-1,6-BP}]_g = P_1, \\ x_7 &= [\text{ADP}]_g = P_2, \\ c_{4,1} &= V^+ = 780 \text{ nmol}(\text{min})^{-1}(\text{mg cell protein.})^{-1}, \\ c_{4,2} &= \frac{1}{k_{4,4}} = \frac{1}{K_{\text{m,Fru6P}_g}} = \frac{1}{0.82} = 1.2195 \text{ (mM)}^{-1}, \\ c_{4,3} &= \frac{1}{k_{4,6}} = \frac{1}{K_{\text{m,ATP}_g}} = \frac{1}{0.026} = 38.4615 \text{ (mM)}^{-1}, \\ n &= 1.2, \end{aligned}$$

So for this equation $v_{\text{PFK}} = r_4$ and the state variables that are contained in r_4 are x_4 , x_6 , x_5 and x_7 . The number of constants in this equation is three. Again the first constant represents V^+ , and the last two constant denotes, respectively, the inverses of the Michaelis-Menten constants of $K_{\text{m,Fru6P}_g}$ and $K_{\text{m,ATP}_g}$.

Now a few examples have been considered of reformulating the rate equations. The rate equations of the further reactions that are discussed below can be found in the appendix, for these the same method is used.

In the fifth reaction equation the enzyme ALD works according to the so called uni-bi mechanism. Glyceraldehyde 3-phosphate dissociates from the enzyme before DHAP does. The reaction rate from GA-3-P_g to 1,3-BPGA_g, which is catalyzed by GAPDH, is r_7 and the rate equations of the reactions that are catalyzed by PGK, GDH and GK, are, respectively, r_8 , r_{13} and r_{17} .

The rate equations of pyruvate that is transported across the plasma membrane and reaction 15, which is catalyzed by GPO are both described by irreversible Michaelis-Menten equations. These rate equations, r_{12} and r_{15} , are also found in the appendix. The relation of ATP utilization is assumed to be close to linear and the rate equation corresponds to a Michaelis-Menten reaction, with dominant product inhibition, that is far from equilibrium [2]. The rate equation for ATP utilization is r_{18} .

Since the rate equations are known now, the differential equations can be discussed.

Differential equations

The process of glycolysis of *Trypanosoma brucei* is described by a set of ten differential equations and a set of algebraic equations, consisting of the moiety-conservation relations, pools and relations for the fast dynamics. In fact it is also described by the algebraic equations that can be obtained by these relations. In this part of the section the set of differential equations is discussed.

The process is described by only ten differential equations. This because several reactions reach equilibrium very fast and are assumed to be in equilibrium. For other processes, for example the transport over the membrane of 3-PGA, Gly-3-P and DHAP, nothing is known about their kinetics [2]. So these steps are also assumed to be in equilibrium. For the substances that are assumed to be in equilibrium, pools exist and there exists a differential equation of the pool.

The differential equations, which describe the time-dependent behavior of the glycolysis of *Trypanosoma brucei* are denoted by $\dot{x}_i(t) = \frac{dx_i}{dt}$, where $\dot{x}_i(t)$ is often denoted by \dot{x}_i . The differential equations consist of the rate equations, and are divided by the associated compartmental volume to get the derivative of the state variables in $mM \text{ min}^{-1}$. This dependent on the compartment concerned. So the differential equation for a particular state consists of the production rate of that state minus the consumption rate of that state, to produce an other state variable, divided by the compartmental volume.

First the differential equations can be written as a sum of rates after which the rate equations can be inserted. So then the ten differential equations

contain most of the 37 state variables. A few of the state variables only come up in the algebraical equations. Also all the values for the constant variables are filled in. These are the values as given in [2] and are also found together with the rate equations in the appendix.

There are a few constants that are used more often. These are the constants for the total volume, the glycosomal volume and the volume of the cytosol. The glycosomal volume is denoted by c_g and the volume of the cytosol is denoted by c_c . The total volume is the sum of both the cytosolic and the glycosomal volumes. These volumes are denoted by

$$\begin{aligned} c_g &= V_g &= \text{volume glycosome} &= 0.2451 \mu\text{l}(mg)^{-1}, \\ c_c &= V_c &= \text{volume cytosol} &= 5.4549 \mu\text{l}(mg)^{-1}, \\ c_{tot} &= V_{tot} &= \text{total volume cytosol} + \text{total volume glycosome} \\ & & &= 5.7 \mu\text{l}(mg)^{-1}. \end{aligned}$$

These constant are used in the differential equations used in inverse form, these are denoted by an extra 1 in the index. Thus we have as extra constants c_{tot1} , c_{g1} , and c_{c1} , which are, respectively, $1/c_g$, $1/c_c$, and $1/c_{tot}$. The values of the constants are rounded to four decimals. In Maple, which is the program that is used for calculations, the values are not round.

The first differential equation describes the change in time of glucose in the glycosome. This is the rate in which glucose enters the glycosome minus the rate of phosphorylation by the enzyme HK in Glc-6-P, divided by the total cell volume. For the change of the glucose concentration in the glycosome the following differential equation is considered [2, p.37, (2.23)]:

$$\begin{aligned} \frac{d[\text{Glc}]_{\text{in}}}{dt} &= \frac{v_{\text{glucose transport}} - v_{\text{HK}}}{V_{\text{tot}}} \\ \dot{x}_1 &= c_{tot1}(r_1 u_1 - r_2 u_2) = \\ &= 9.3158 \frac{(x_2 - x_1) u_1}{(1 + 0.5x_2 + 0.5x_1 + 0.1875x_1x_2)} \\ &\quad - 9450.5106 \frac{x_6 x_1 u_2}{(1 + 8.6207x_6 + 7.9365x_7)(1 + 10x_1)} \\ x_1 &= [\text{Glc}]_g \\ r_1 u_1 &= v_{\text{glucose transport}} \\ r_2 u_2 &= v_{\text{HK}} \\ c_{tot1} &= \frac{1}{c_{tot}} = \frac{1}{V_{tot}} = \frac{1}{5.7} = 0.1754 (\mu\text{l}/mg)^{-1}. \end{aligned}$$

Assuming that the reaction between Glc-6-P and Fru-6-P is in equilibrium, these substances are considered together as a Hexose-P pool. So a differential equation exists for this pool. The enzyme HK facilitates production of Glc-6-P from glucose in the glycosome and by PFK, Fru-6-P is consumed

to produce Fru-1,6-BP. The following differential equation is found for the Hexose-P pool [2, p.37, (2.24)]:

$$\begin{aligned}
\frac{d[\text{hexose-P}]_g}{dt} &= \frac{v_{\text{Glucose transport}} - v_{\text{HK}}}{V_g} \\
\dot{x}_{30} &= c_{g1}(r_2u_2 - r_4u_4) = \\
&= 219825.8276 \frac{x_6x_1u_2}{(1 + 8.6207x_6 + 7.9365x_7)(1 + 10x_1)} \\
&\quad - 155310.6798 \frac{x_4^{1.2}x_6u_4}{(1 + 1.2689x_4^{1.2})(1 + 38.4615x_6)} \\
x_{30} &= [\text{hexose-P}]_g \\
r_2u_2 &= v_{\text{HK}} \\
r_4u_4 &= v_{\text{PFK}} \\
c_{g1} &= \frac{1}{c_g} = \frac{1}{V_g} = \frac{1}{0.2451} = 4.0799 \text{ } (\mu\text{l}/\text{mg})^{-1}.
\end{aligned}$$

The other differential equations are also be calculated out and can be found in the appendix. The third differential equation is for the change in Fru-1,6-BP. The fourth differential equation is for the concentration of the Triose-P pool,

$$[\text{Triose-P}] = \frac{[\text{DHAP}]_c V_c + [\text{DHAP}]_g V_g + [\text{GA-3-P}]_g V_g}{V_{\text{tot}}}.$$

We use here the assumption that the reactions between $[\text{DHAP}]_c$ and $[\text{DHAP}]_g$ and between $[\text{DHAP}]_g$ and $[\text{GA-3-P}]_g$ are at equilibrium. The fifth differential equation is for 1,3-BPGA, since also the reactions,

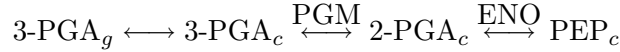

are assumed to be in equilibrium. So a pool consists for these states, namely

$$[\text{N}] \equiv \frac{[3\text{-PGA}](V_g + V_c) + [2\text{-PGA}]_c V_c + [\text{PEP}]_c V_c}{V_{\text{tot}}}$$

and a differential equation consists for this pool. The seventh differential equation is for the pyruvate concentration in the cytosol and the eight is for the NADH concentration in the glycosome. The ninth and the tenth differential equations are respectively for the pools of high energy phosphates in the glycosome and in the cytosol. These pools are,

$$P_g \equiv 2[\text{ATP}]_g + [\text{ADP}]_g$$

and

$$P_c \equiv 2[\text{ATP}]_c + [\text{ADP}]_c.$$

Finally the set of differential equations is the following:

$$\begin{aligned}
\dot{x}_1 &= c_{\text{tot}1}(r_1 u_1 - r_2 u_2) &= \frac{v_{\text{Glucose transport}} - v_{\text{HK}}}{V_{\text{tot}}} \\
\dot{x}_{30} &= c_{g1}(r_2 u_2 - r_4 u_4) &= \frac{v_{\text{HK}} - v_{\text{PFK}}}{V_g} \\
\dot{x}_5 &= c_{g1}(r_4 u_4 - r_5 u_5) &= \frac{v_{\text{HK}} - v_{\text{PFK}}}{V_g} \\
\dot{x}_{31} &= c_{\text{tot}1}(2r_5 u_5 - r_7 u_7 - r_{13} u_{13} + r_{15} u_{15}) &= \frac{2v_{\text{ALD}} - v_{\text{GAPDH}} - v_{\text{GDH}} + v_{\text{GPO}}}{V_{\text{tot}}} \\
\dot{x}_{12} &= c_{g1}(r_7 u_7 - r_8 u_8) &= \frac{v_{\text{GAPDH}} - v_{\text{PGK}}}{V_g} \\
\dot{x}_{35} &= c_{\text{tot}1}(r_8 u_8 - r_{11} u_{11}) &= \frac{v_{\text{PGK}} - v_{\text{PYK}}}{V_{\text{tot}}} \\
\dot{x}_{16} &= c_{c1}(r_{11} u_{11} - r_{12} u_{12}) &= \frac{v_{\text{PYK}} - v_{\text{Pyruvate transport}}}{V_c} \\
\dot{x}_{25} &= c_{g1}(r_7 u_7 - r_{13} u_{13}) &= \frac{v_{[\text{GAPDH}]} - v_{\text{GDH}}}{V_g} \\
\dot{x}_{36} &= c_{g1}(-r_2 u_2 - r_4 u_4 + u_8 r_8 + r_{17} u_{17}) &= \frac{-v_{\text{HK}} - v_{\text{PFK}} + v_{\text{PGK}} + v_{\text{GK}}}{V_g} \\
\dot{x}_{37} &= c_{c1}(r_{11} u_{11} - r_{19} u_{19}) &= \frac{v_{\text{PYK}} - v_{\text{ATP utilization}}}{V_c}
\end{aligned}$$

It is remarkable that the biochemical reaction network can be modelled by these ten differential equations. But recall that several reactions are assumed to be in equilibrium. For example nothing is known about the kinetics of the transport of 3-PGA, Gly-3-P and DHAP. So these transports are assumed to be in equilibrium. In the appendix one can find the complete set of differential equations with all the states and constants filled in.

In this part of the section the set of differential equations is discussed. In the following parts respectively the moiety equations, pools and fast dynamics and algebraic equations will be discussed.

Algebraic equations

Now the algebraic equations for the model will be discussed. As already mentioned the algebraic equations consist of moiety-conservation relations, fast dynamics and pools. The pools of the model were already used to derive the set of differential equations. Further, other algebraic equations are obtained by the moiety-conservation relations and fast dynamics.

Moiety conservations are subgroups of metabolites which are conserved during the evolution of a network. The sum of the concentrations of metabolites in the mass conservation relation is constant. In this model four moiety-conservation relations are considered [2]. The moiety equations consist of the state variables, the constants c_c and c_g , and the constants c_1, \dots, c_4 , which are the constant values of the sums of metabolite concentrations.

There are moiety-conservation relations for ATP, ADP and AMP in the glycosol and in the cytosol, both with a sum of 3.9 mM . Also the concentration of NAD^+ is conserved throughout the time and by this the sum of NADH and NAD^+ is constant, 4 mM . The fourth moiety-conservation relation is a relation for organic phosphate.

As one can find in the biochemical reaction network the moiety-conservation relation for organic phosphate is a relation between the substances Glc-6-P_g, Fru-6-P_g, Fru-1,6-P_g, DHAP_g, GA-3-P_g, DHAP_c, Gly-3-P_c, Gly-3-P_g, 1,3-BPGA_g, 3-PGA_g, ATP_g and ADP_g. It consists of the states x_{11} , x_{21} , x_9 , x_{10} , x_{12} , x_6 , and x_7 . The states are multiplied with the compartment constants, since some are found in the cytosol and others in the glycosome. Also the constant c_4 , which is 120 *mM* is multiplied with c_g . The states x_5 and x_6 are multiplied by a factor of two, since they contain two phosphate groups, which both are transferred to other substances. So the moiety-equation is equal to

$$c_4c_g = x_{11}c_g + x_{21}c_c + x_9c_g + x_{20}c_c + x_3c_g + x_4c_g \\ + 2x_5c_g + x_{10}c_g + x_{12}c_g + 2x_6c_g + x_7c_g.$$

The other moiety equations can be found in Appendix A.3.4.

Other reasons for the algebraic equations are equilibrium reactions and metabolite pools. Some of the reactions in the reaction network are considered to be in equilibrium. For these reactions equilibrium equations can be formulated. The substrates and products of an equilibrium reaction can be seen as a single metabolite pool [2]. So pool relations can be formulated.

The substances Gly-3-P, DHAP and 3-PGA where assumed to be in equilibrium across the membrane. So the concentrations in the cytosol are assumed to be equal to the concentrations of these species in the glycosome. Now state variables are introduced for these substances, which is a concentration in both compartments. So x_{28} , x_{29} and x_{33} are respectively state variables for [Gly-3-P], [DHAP] and for [3-PGA]. One can find this relation in Appendix A.3.6.

Some reactions reach equilibrium very fast and are assumed to be in equilibrium. This is the case for five reactions in the network, namely for the reaction (3) from Glc-6-P to Fru-6-P, in the glycosome, catalyzed by PGI. Also the reaction catalyzed by TIM (6) is assumed to be in equilibrium. This is also the case for the reaction from 3-PGA in the cytosol to PEP in the cytosol. This occurs in two steps by the enzymes PGM (9) and ENO (10). Finally the reactions from two ADP into one ATP and one AMP is also assumed to be in equilibrium.

For these five reactions equilibrium equations are derived in [2]. An equilibrium equation consists of the state variables in a specific reaction equation and of an equilibrium constant. This equilibrium constant is denoted by $c_{\text{eq},i}$, with $i \in \mathbb{N}$ the number of the enzyme. The right hand side of an equilibrium equation consist of the product of the state variables on the right hand side of the reaction equation, divided by the state variables on the left hand side. The left hand side of an equilibrium equation is the equilibrium constant. So the relation between substances on both sides of the reactions is linear.

An example of an equilibrium equation is the reaction catalyzed by PGI [2, p.39, (2.33)],

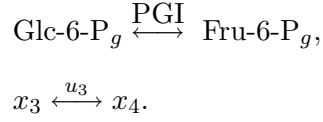

The equilibrium equation by this reaction is

$$\frac{[\text{Fru-6-P}]_g}{[\text{Glc-6-P}]_g} = K_{\text{eq,PGI}},$$

$$\frac{x_4}{x_3} = c_{\text{eq},3},$$

$$x_4 = [\text{Fru-6-P}]_g,$$

$$x_3 = [\text{Glc-6-P}]_g,$$

$$c_{\text{eq},3} = K_{\text{eq,PGI}} = 0.29.$$

The other equilibrium equations can be found in Appendix A.3.6.

The model contains five pools, namely a pool of the hexose-P concentration in the glycosome, a pool of the triose-phosphate concentration in the glycosome, a N pool and two pools of high energy phosphates, P_g , and P_c , which consist of ATP and ADP in the glycosome and in the cytosol.

The pools consist of the state variables and the glycosomal, the cytosolic and the total cell volume, c_g , c_c and c_{tot} . New states that are introduced are x_{30} , x_{31} , x_{35} , x_{36} , and x_{37} , which stand respectively for [Hexose-P], [Triose-P], [N], $[P]_g$ and $[P]_c$.

An example is the sum of hexose phosphates in the glycosome, [2, p.37, (2.16)],

$$[\text{hexose-P}]_g \equiv [\text{Glc-6-P}]_g + [\text{Fru-6-P}]_g,$$

$$x_{30} \equiv x_3 + x_4,$$

$$x_{30} = [\text{hexose-P}]_g,$$

$$x_3 = [\text{Glc-6-P}]_g,$$

$$x_4 = [\text{Fru-6-P}]_g.$$

The notation of the other pools can be found in the appendix.

With the help of the moiety-conservation relations, pools and the fast dynamics, algebraic equations can be found, describing relations between some of the state variables. By this way algebraic relations can be found between Hexose-P, x_{30} , and Glc-6-P, x_3 , in the glycosome.

The following relation is obtained between these x_{30} and x_3 , [2, p.37, (2.16)] and [2, p.39,(2.33)]:

$$\begin{aligned}
\frac{[\text{hexose-P}]_g}{1 + K_{\text{eq,PGI}}} &\stackrel{[2,(2.16)]}{=} \frac{[\text{Glc-6-P}]_g + [\text{Fru-6-P}]_g}{1 + K_{\text{eq,PGI}}} = \\
&\stackrel{[2,(2.33)]}{=} \frac{[\text{Glc-6-P}]_g + [\text{Fru-6-P}]_g}{1 + \frac{[\text{Fru-6-P}]_g}{[\text{Glc-6-P}]_g}} = \\
&= \frac{[\text{Glc-6-P}]_g^2 + [\text{Glc-6-P}]_g \cdot [\text{Fru-6-P}]_g}{[\text{Glc-6-P}]_g + [\text{Fru-6-P}]_g} = \\
&= [\text{Glc-6-P}]_g,
\end{aligned}$$

this gives

$$\frac{x_{30}}{1 + c_{eq,3}} = x_3.$$

Two other algebraic relations that consist are those between [Triose-P] and [DHAP] and between [N] and [3-PGA]. So between x_{31} and x_{29} and between x_{35} and x_{33} . These calculation can be found in Appendix A.3.7

In the Appendix B one can find a list of all equations that are considered in the mathematical model of glycolysis of *Trypanosoma brucei*. The list contains the rate equations, differential equations, moiety equations, equilibria, pools, equilibria equations and the derived algebraic equations.

3.5.2 Reduction of state variables

For the model of glycolysis in *Trypanosoma brucei* a model of ten differential equations and a set of algebraic equations is available now. We are interested in a model of ten differential equations and with, matching, ten unknown state variables. To determine such a system, the state variables have to be reduced in a set of state variables, in which all states are expressed as a relation of the ten states of interest, with the help of the algebraic equations. After this a reduced system can be made.

So in this section the set of 25 of the total 37 state variables,

$$\{x_3, x_4, x_6, x_7, x_8, x_9, x_{10}, x_{11}, x_{14}, x_{15}, x_{17}, x_{18}, x_{19}, x_{20}, x_{21}, x_{22}, x_{23}, x_{24}, x_{26}, x_{27}, x_{28}, x_{29}, x_{32}, x_{33}, x_{34}\},$$

will be written as a relation of the state variables in the set,

$$\{x_1, x_{30}, x_5, x_{31}, x_{12}, x_{35}, x_{16}, x_{25}, x_{36}, x_{37}\}.$$

These ten state variables are respectively concentrations for Glc_g , Hexose-P_g , Fru-1,6-BP_g , Triose-P , 1,3-BPGA_g , N , Pyruvate_c , NADH_g , P_g , and P_c . The states x_2 and x_{13} are exceptions, because they are assumed to be respectively 5 and 0, [2]. Here x_2 is the external glucose concentration and x_{13} is the concentration glycerol in the glycosome.

When elimination is done, we shall see that most of the relations between the states are linear relations of the ten state variables in the system, except x_6 , x_7 , x_8 , x_{17} , x_{18} , and x_{19} . The latter variables are respectively the concentrations ATP, ADP, and AMP in the glycosome and in the cytosol. Since the algebraic relations between these states leads to quadratic equations for x_6 and x_{17} , depending of respectively x_{36} and x_{37} , which are the high energy phosphates in the glycosome and in the cytosol. Because of these equations x_6 is depending on x_{36} with a nonlinear relation and x_7 is depending of x_{37} with the same relation. Since x_7 and x_8 depend on x_6 , the relation between these states and x_{36} is also nonlinear, so also the relations between x_{18} and x_{19} , and x_{37} . As one can find in the appendix, these relations are

$$\begin{aligned}
x_6 &= 2.5391 + 0.5000x_{36} - 0.6510\sqrt{(3.9 + 0.768x_{36})^2 - 1.3578x_{36}^2}, \\
x_7 &= 0.2 \cdot 10^{-9}x_{36} - 5.0781 + 1.3021\sqrt{(3.9 + 0.768x_{36})^2 - 1.3578x_{36}^2}, \\
x_8 &= 6.4391 - 0.5000x_{36} - 0.6510\sqrt{(3.9 + 0.768x_{36})^2 - 1.3578x_{36}^2}, \\
x_{17} &= 2.5391 + 0.5000x_{37} - 0.6510\sqrt{(3.9 + 0.768x_{37})^2 - 1.3578x_{37}^2}, \\
x_{18} &= 0.2 \cdot 10^{-9}x_{37} - 5.0781 + 1.302\sqrt{(3.9 + 0.768x_{37})^2 - 1.3578x_{37}^2}, \\
x_{19} &= 6.4391 - 0.5000x_{37} - 0.6510\sqrt{(3.9 + 0.768x_{37})^2 - 1.358x_{37}^2}.
\end{aligned}$$

As one can see these relations contain the square root of $(3.9 + 0.768x_{36})^2 - 1.3578x_{36}^2$ or the square root of $(3.9 + 0.768x_{37})^2 - 1.3578x_{37}^2$. We shall see when checking positivity that these states are positive for x_{36} and x_{37} contained in a specific set.

Determination of the other expressions of state variables can be found in the appendix. One can find a list of the state variables and their expressions in Appendix A.3.8 as well.

The following subsection is about the system of differential equations after the reduction of state variables.

3.5.3 The system of differential equations after reduction of state variables

In the last subsection the set of state variables has been reduced to a set of only ten state variables. The other state variables can be expressed in these

ten variables. In this subsection, the expressions are used to simplify in the set of differential equations. The result is a set of ten differential equations with ten unknown state variables, namely the variables in the set $\{x_1, x_{30}, x_5, x_{31}, x_{12}, x_{35}, x_{16}, x_{25}, x_{36}, x_{37}\}$.

So the set of state variables in the system of differential equations is reduced. On the other hand some of the individual differential equations became rather complex, when these expressions were calculated. For example the differential equations for the states x_{31} and x_{36} are complex.

The computer program Maple is used for determining the set of differential equations after reducing the state variables. All the expressions of the state variables, the rate equations, and the differential equations are calculated with Maple. In this way the set of differential equations after reduction of state variables is obtained. Also the constants in the system of differential equation are inserted. Here the constants are rounded to four decimals. For calculations in Maple the real values of the constants are used. For some expressions that are contained in the differential equations an function is introduced. By this S , S_1 , $c_{5,3}$, and $c_{11,2}$ are introduced, this to simplify the complexity of the system.

An example of a differential equation after reduction of state variables is the differential equation for glucose in the glycosome, x_1 . The differential equations for x_1 is

$$\frac{dx_1}{dt} = 9.3158 \frac{(5 - x_1) u_1}{(3.5 + 1.4375x_1)} - 9452.5106 \frac{(2.5391 + 0.5000x_{36} - 0.6510 \cdot S) x_1 u_2}{(-17.4141 + 4.3103x_{36} + 4.7216 \cdot S) (1 + 10x_1)},$$

with

$$S = \sqrt{(3.9 + 0.768x_{36})^2 - 1.3578x_{36}^2}.$$

So the state x_2 is assumed to be 5 and the states x_6 and x_7 are expressed in x_{36} . The variable S denotes the square root. One can find the other differential equations in the appendix.

Finally to complete the dynamical model, the output variables of the model can be considered. This is done in the following subsection.

3.5.4 Determination of output variables

Finally the output variables of the dynamical system will be discussed. In this report these outputs are the state variables in the system which are produced during glycolysis in *Trypanosoma brucei*, but which are not consumed and also the state variables of interest are considered as output variables.

The output variables of the system are defined by a vector y , which is a vector in \mathbb{R}_+^6 ,

$$y = \begin{pmatrix} y_1 \\ \vdots \\ y_6 \end{pmatrix}$$

with y_i , $i = 1, \dots, 6$. In this vector the output variables all correspond with a specific state variable, where the state variable for ATP is split up in two output variables.

In this model the state variables which are denoted as output variables are pyruvate outside the cell, H_2O in the mitochondrion, ATP in the glycosome and in the cytosol and the extern concentration of glycerol. Actually ATP is the state variable of interest, and it is also produced in the cytosol. So both ATP produced and ATP consumed in the glycosome are considered as output variables. So now we have for y_i , $i = 1, \dots, 6$,

$$\begin{aligned} y_1 &= x_{6(1)} = [\text{ATP}]_g \text{ produced,} \\ y_2 &= x_{6(2)} = [\text{ATP}]_g \text{ consumed,} \\ y_3 &= x_{13} = [\text{Glycerol}]_g, \\ y_4 &= x_{16} = [\text{Pyruvate}]_c, \\ y_5 &= x_{17} = [\text{ATP}]_c, \\ y_6 &= x_{22} = [\text{H}_2\text{O}]. \end{aligned}$$

The output variables are obtained by using the rate equations, with the help of the network of reaction equations. When an output variable is only produced, the variable is the sum of the production rates times the corresponding inputs. When it is only consumed, $x_{6(2)}$, it is the sum of the rate equations times -1 .

So the output variables are functions of the rate equations. In the case of glycolysis in *Trypanosoma brucei* it are functions of r_{11} , r_{15} , r_{17} , r_8 , r_2 , and r_4 . So this afford that indeed $y = H \text{Diag}(r(x(t), x_{ex}))u(t)$, with $u(t)$ a constant. For glycolysis of *Trypanosoma brucei* we found that

$$\begin{aligned} y_1 &= r_{17}u_{17} + r_8u_8, \\ y_2 &= -r_2u_2 - r_4u_4, \\ y_3 &= r_{17}u_{17}, \\ y_4 &= r_{11}u_{11}, \\ y_5 &= r_{11}u_{11}, \\ y_6 &= r_{15}u_{15}. \end{aligned}$$

Thus the entries, of the matrix H , $h_{1,17}$, $h_{1,18}$, $h_{3,17}$, $h_{4,11}$, $h_{5,11}$, and $h_{6,16}$ are equal to 1 and h_2 and h_4 are equal to -1. The other entries of the matrix H are equal to zero.

As an example y_1 can be considered. First y_1 will be given in general formula, after this the rate equations will be filled in and finally $x_{6(1)}$ will be given after reduction of state variables. Now the following is found for y_1 :

$$\begin{aligned}
x_{6(1)} &= r_{17}u_{17} + r_8u_8 = \\
&= c_{17,1} \frac{(x_{11}c_{17,3}x_7c_{17,4} - c_{17,2}x_{13}c_{17,5}x_6c_{17,6})u_{17}}{(1 + x_{11}c_{17,3} + x_{13}c_{17,5})(1 + x_7c_{17,4} + x_6c_{17,6})} \\
&\quad + c_{8,1} \frac{(x_{12}c_{8,3}x_7c_{8,4} - c_{8,2}x_{14}c_{8,5}x_6c_{8,6})u_8}{(1 + x_{12}c_{8,3} + x_{14}c_{8,5})(1 + x_7c_{8,4} + x_6c_{8,6})} = \\
&= 199.9967 \frac{(1.6342x_{11}x_7 - 7324.5907x_{13}x_6)u_{17}}{(1 + 0.1961x_{11} + 8.3333x_7)(1 + 8.3333x_{13} + 5.2632x_6)} \\
&\quad + 639.9894 \frac{(200x_{12}x_7 - 0.0617x_{14}x_6)u_8}{(1 + 20x_{12} + 0.6173x_{14})(1 + 10x_7 + 3.4483x_6)} \\
&= \frac{639.9894 \cdot 200x_{12} (-5.0781 + 1.3021 \cdot S) u_8}{(1 + 20x_{12} + 0.2596x_{35}) (-41.0259 + 1.7241x_{36} + 10.7759 \cdot S)} \\
&\quad - \frac{639.9894 \cdot 0.0260x_{35} (2.5391 + 0.5000x_{36} - 0.6510 \cdot S) u_8}{(1 + 20x_{12} + 0.2596x_{35}) (-41.0259 + 1.7241x_{36} + 10.7759 \cdot S)} \\
&\quad + \frac{(5.1600 - 1.0000x_{31} - 0.0430x_{30} - 0.0860x_5 - 0.0430x_{12} - 0.0430x_{36})}{(2.0118 - 0.1961x_{31} - 0.0084x_{30} - 0.0169x_5 - 0.0084x_{12} - 0.0084x_{36})} \\
&\quad \cdot \frac{199.9967 (-5.0781 + 1.3021 \cdot S) u_{17}}{(-27.9542 + 2.6316x_{36} + 7.4242 \cdot S)}.
\end{aligned}$$

Bu reaction 17 and reaction 8 ATP is produced in the glycosome, respectively the reaction of Gly-3-P to Glycerol and the reaction of 1,3-BPGA to 3-PGA.

One can find the expressions of the other output variables in appendix A.3.10, with the help of the rate equations before and after reduction of state variables.

We have explained, in this chapter, how to make a dynamical system for a biochemical reaction network. First a biochemical model has to be made and second a mathematical model has to be made. This is explained by the example of glycolysis in *Trypanosoma brucei*. In the following chapter the system properties positivity of dynamical systems of biochemical reaction networks and steady state of such systems will be discussed. For the model of glycolysis in *Trypanosoma brucei* it will be checked that the system is positive and a steady state will be determined numerically.

Chapter 4

Dynamical System Properties

In the last chapter dynamical systems for biochemical reaction networks are considered. These systems consist of a set of differential equations and a set of algebraic equations. The variables in the system are the input, the state and the output variables.

A system of differential equations and algebraic equations has dynamical system properties. These dynamical system properties are properties that differ for particular systems. Dynamical system properties can be verified by analysis of the equations of the dynamical system and can be expressed in formulas. Examples of dynamical system properties are positivity of the system, observability, controllability, periodic solutions, and steady state properties.

In this chapter positivity of the system will be checked and questions about steady state will be considered. Since states of systems for biochemical reaction networks are concentrations, these state variables have to be positive. This is discussed in Appendix A.4. In this chapter definitions and theorems about positivity in general are presented. After this positivity is considered for biochemical reaction networks. And we shall discuss how to determine positivity of a dynamical system for biochemical reaction networks in general.

In Section 4.2 positivity of the model of glycolysis of *Trypanosoma brucei* is checked as an example of a biochemical reaction network. In this section the methods of determining positivity for the model of glycolysis for *Trypanosoma brucei* is discussed. We will also start in this section with determining positivity, this will be continued in Appendix A.4.

Often one is mainly interested to know the value of the output variables under steady state conditions, but the values of the state variables under

these conditions are of interest to. This is why considering steady state properties is important. The steady state is considered in Section 4.4.

Important questions that can be asked, about steady states, are questions about whether a steady state exists and if it exists whether it is unique. Another question can be whether the steady state of a system, if it exist and if it is stable, it is asymptotically stable and whether it is globally asymptotically stable. The articles, [23], and [10] are used to discuss these phenomena. A method to determine a set of steady states is explained in this section. We will also discuss uniqueness and stability of the steady state.

In this chapter system properties for biochemical reaction networks are considered. In Section 4.6 steady state values are determined for the model of glycolysis of *Trypanosoma brucei* as an example. We shall determine the steady state values numerically. We will discuss if there is a steady state, which will be reached from every state.

In the first section of this chapter positivity is considered and in the second section positivity for the model of glycolysis of *Trypanosoma brucei* is considered. In the last two sections the steady state for the example of *Trypanosoma brucei* is considered.

4.1 Positive systems for biochemical reaction networks

One of the properties of a dynamical system is positivity. In this section of positivity of dynamical systems will be discussed, which is useful for dynamical systems of biochemical reaction networks.

Positivity of a dynamical system means that all state variables of the system are positive, which means, with our definitions, larger than or equal to zero. For a dynamical system of a biochemical reaction network this is an important system property. Since the states are all concentrations, they have to be larger than or equal to zero, for the complete period $t \in [t_0, \infty)$, which is a continuous subset of the real numbers.

So for every $t \in [t_0, \infty)$ the state vector x is a positive vector, $x \in \mathbb{R}_+^n$. The input vector u is also a positive vector, $u \in \mathbb{R}_+^k$, since negative enzyme concentrations are impossible. Also the output, y of the system, which is often a vector of concentrations of the state variables of interest, has to be positive, $y \in \mathbb{R}_+^p$, because it is a vector of concentrations.

Thus when the system has positive input variables, and the initial value, for the state of the system is also positive, then both the state vector, x , and the output vector, y , have to be positive for $t \in [t_0, \infty)$. The definition of positivity of a dynamical system follows:

Definition 4.1 [28, p.19, (2.1.1)]

A continuous-time positive dynamical system is a dynamical system in the form of a differential equation,

$$\begin{aligned}\dot{x}(t) &= f(t, x(t), u(t)), \quad x(t_0) = x_0, \\ y(t) &= h(t, x(t), u(t)),\end{aligned}$$

$f : [t_0, \infty) \times \mathbb{R}_+^n \times \mathbb{R}_+^k \rightarrow \mathbb{R}_+^n$, $h : [t_0, \infty) \times \mathbb{R}_+^n \times \mathbb{R}_+^k \rightarrow \mathbb{R}_+^p$, $n, k, p \in \mathbb{Z}_+$, such that, if $x_0 \in \mathbb{R}_+^n$ and $u : [t_0, \infty) \rightarrow \mathbb{R}_+^k$ then there exist a state and output trajectory: $x : [t_0, \infty) \rightarrow \mathbb{R}_+^n$ and $y : [t_0, \infty) \rightarrow \mathbb{R}_+^p$, both taking values in a positive vector space over the positive real numbers.

So a dynamical system of a biochemical reaction network has to be a positive system. To prove positivity of a dynamical system one has to prove that the positive orthant, \mathbb{R}_+^n , is a positive invariant subset, also called a forward invariant subset. A subset is called invariant if whenever the initial value, $x = x_0$, is contained in the subset at initial time, $t = t_0$, then the state trajectory will stay in this subset. So $x(t)$ is contained in this subset for all $t \in [t_0, \infty)$. Now the positive orthant is invariant, when $x_0 \in \mathbb{R}_+^n$ at $t = t_0$ imply that $x(t) \in \mathbb{R}_+^n$, $\forall t \in [t_0, \infty)$.

For the trajectory to stay inside a specific subset, a state on the boundary has to stay either on the boundary or has to move, from the boundary, into the interior of the subspace. For the positive orthant to be invariant the set of differential equations has to be positive for a state at the boundary of the positive orthant, $\frac{dx_i}{dt} \geq 0$, when $x_i = 0$. A state is at the boundary of the positive orthant if one of the components of the state vector is equal to zero, $\{\exists i \in \mathbb{Z}_n | x_i = 0\}$.

Now a definition of time-invariant continuous-time real nonlinear systems is given. After this a theorem for positive invariance of the positive orthant.

Definition 4.2 [28, p.20, (2.1.2)]

Consider an autonomous time-invariant continuous-time real nonlinear system with representation

$$\dot{x}(t) = f(x(t)), \quad x(t_0) = x_0.$$

The subset $X \subseteq \mathbb{R}^n$ is said to be positively invariant for this system if for all $x_0 \in X$ the state trajectory satisfies that $x(t) \in X$ for all $t \in [t_0, \infty)$.

Theorem 4.3 Consider the nonlinear continuous system, not necessarily positive,

$$\dot{x}(t) = f(x(t)), \quad x(t_0) = x_0.$$

The positive orthant is a positively invariant subset if and only if for all $i \in \mathbb{Z}_n$ and for all $x \in \mathbb{R}_+^n$ with $x_i = 0$ it is true that $f_i(x) \geq 0$.

It is possible for a system to have a state vector, which is strictly positive. This is the case if for every state on the boundary, with $x_i = 0$, $\frac{dx_i}{dt} > 0$. A nonlinear positive system is called strictly positive if the interior of the positive orthant is positive invariant. When the system is restricted by a under boundary, $s \in \mathbb{R}_{s+}^n$, the system is called boundary positive, with under boundary, if all $x_i \geq s_i$, $\forall i \in \mathbb{Z}_n$. The system is called boundary positive, with upper boundary, if all $s_i \geq x_i$, $\forall i \in \mathbb{Z}_n$.

The following definitions and theorem are definitions for strict positivity of a nonlinear real system, a theorem of a nonlinear positive system and the definition of bounded positivity, with an under boundary and an upper boundary of a nonlinear system.

Definition 4.4 [28, p.21, (2.1.4)]

A nonlinear positive system,

$$\dot{x}(t) = f(x(t)), \quad x(t_0) = x_0, \quad X = \mathbb{R}_+^n,$$

is called strictly positive if $\text{int}(\mathbb{R}_+^n)$ is a positively invariant subset of this system: $\forall x_0 \in \mathbb{R}_+^n$. So if

$$\forall x_0 \in \text{int}(\mathbb{R}_+^n), \quad \forall t \in T, \quad x(t) \in \text{int}(\mathbb{R}_+^n).$$

Theorem 4.5 [28, p.21, (2.1.5)]

A nonlinear real system

$$\dot{x}(t) = f(x(t)), \quad x(t_0) = x_0, \quad X = \mathbb{R}^n,$$

is strictly positive if and only if for all $i \in \mathbb{Z}_n$ and for all $x \in \mathbb{R}_+^n$ with $x_i = 0$, $f_i(x) > 0$.

Definition 4.6 [28, p.21, (2.1.6)]

A nonlinear real system

$$\dot{x}(t) = f(x(t)), \quad x(t_0) = x_0, \quad X = \mathbb{R}^n,$$

is called bounded positive, with under boundary, if there exist a strictly positive state $s \in \mathbb{R}_{+s}^n$ such that the subset

$$X(s) = \{x \in \mathbb{R}_+^n \mid \forall i \in \mathbb{Z}_n, x_i \geq s_i\}$$

is positively invariant.

Definition 4.7 *A nonlinear real system*

$$\dot{x}(t) = f(x(t)), x(t_0) = x_0, X = \mathbb{R}^n,$$

is called bounded positive, with upper boundary, if there exist a strictly positive state $s \in \mathbb{R}_{+s}^n$ such that the subset

$$X(s) = \{x \in \mathbb{R}_+^n \mid \forall i \in \mathbb{Z}_n, s_i \geq x_i\}$$

is positively invariant.

So when a nonlinear continuous-time dynamical system is considered one can check whether this system is positive, strictly positive or whether it is bounded positive.

In the next section it will be proved that the the model of glycolysis for *Trypanosoma brucei* is a continuous-time positive system. Positive invariance of the positive orthant will be checked for this model. The claim for the states, without differential equation, to be larger than zero, leads to some upper boundaries. So we will finally find a subset of the positive orthant, which is positive invariant, the system will be boundary positive.

4.2 Positivity of the model for *Trypanosoma brucei*

In this section positivity of the model for the example *Trypanosoma brucei* will be checked. The method, described in Appendix A.4, for checking positivity of a dynamical system for biochemical reaction networks, will be used in this section. All calculations and determinations in this section are done with the help of Maple. The values are all rounded to four decimals.

The system of glycolysis of *Trypanosoma brucei* is positive if all state variables are contained in the positive orthant. So the positive orthant has to be positive invariant. For the ten differential equations, first $\frac{dx_i}{dt}$ is considered in case $x_i = 0, \forall i \in \{1, 30, 5, 31, 12, 35, 16, 25, 36, 37\}$. If this is the case $x_i = 0$ is an under boundary for the system. When it happens that the state x_i becomes zero, it will stay zero or it will increase and become greater than zero. For all ten differential equations in the system positivity of the matching state will be checked.

The other states, which are expressed in the ten state variables, for which differential equations exist, also have to be positive. When checking positivity of these state variables, some upper boundaries for x_{36}, x_{37} and x_{25} will arise. When a state will reach a particular upper boundary the matching differential equation has to be less or equal to zero. Then the state will stay at the boundary or it will decrease to a lower value. When checking positivity of these state variables also a restriction will arise for x_{11}, x_{18} , and x_{21} .

Checking positivity for the other state variables will be done after checking positivity for the state variables for which a differential equation exist.

First positivity will be checked for the state x_1 . When x_1 is assumed to be zero, the differential equation for x_1 has to be larger or equal to zero. The differential equation for x_1 is

$$\frac{dx_1}{dt} = 9.3158 \frac{x_2 u_1}{1.0 + 0.5 x_2}.$$

The concentration of glucose outside the cell, x_2 , is assumed to be 5 mM, so x_2 is a positive concentration. Also the input variables u_i , $\forall i \in \{1, 30, 5, 31, 12, 35, 16, 25, 36, 37\}$, are larger or equal to zero, so $\frac{dx_1}{dt} \geq 0$. This means that the state x_1 is positive.

When for example the differential equation for x_{31} is considered, it will be seen that it is sure that $\frac{dx_{31}}{dt} \geq 0$ if $c_{53} \geq 0$. This is the case when the upper boundary for x_{36} is used, since $c_{53} \geq 0$ if $x_{36} \in (-2.0173, 9.8175)$. The differential equation for x_{31} is

$$\begin{aligned} \frac{dx_{31}}{dt} = & \frac{64.7368 (c_{53} x_5 - 1184.0796 x_9 x_{10}) u_5}{1 + c_{53} x_5 + x_{10}(14.9254 + 10.2041x_5c_{53} + 995.0249x_9) + 66.6667 x_9} \\ & - 257.8947 \frac{(14.8148 x_{10} x_{24} - 335.0000 x_{12} x_{25}) u_7}{(1 + 6.6667 x_{10} + 10 x_{12}) (1 + 2.2222 x_{24} + 50 x_{25})} \\ & - 74.5614 \frac{(78.4314 x_9 x_{25} - 0.0182 x_{11} x_{24}) u_{13}}{(1 + 1.1765 x_9 + 0.1563 x_{11}) (1 + 66.6667 x_{25} + 1.6667 x_{24})} \\ & + 37.9773 \frac{x_{21} u_{15}}{1 + 0.5882 x_{21}}, \end{aligned}$$

with

$$c_{53} = \frac{1}{0.0282 + 0.0054x_{36} - 0.0025\sqrt{(3.9 + 0.768x_{36})^2 - 1.3578x_{36}^2}}.$$

The state variable x_{31} does not occur explicitly in $\frac{dx_{31}}{dt}$, but since $x_9 = 0.9981x_{31}$ and $x_{10} = 0.0449x_{31}$ the following is obtained for $\frac{dx_{31}}{dt}$ when $x_{31} = 0$:

$$\begin{aligned} \frac{dx_{31}}{dt} = & 64.7368 \frac{c_{53} x_5 u_5}{1.0 + c_{53} x_5} \\ & + 86394.7369 \frac{x_{12} x_{25} u_7}{(1.0 + 10 x_{12})(1 + 2.2222 x_{24} + 50 x_{25})} \\ & + 1.3592 \frac{x_{11} x_{24} u_{13}}{(1.0 + 0.1563 x_{11})(1 + 66.6667 x_{25} + 1.6667 x_{24})} \\ & + 37.9773 \frac{x_{21} u_{15}}{1 + 0.5882 x_{21}}. \end{aligned}$$

All factors in this differential equation have a positive sign, which means that $\frac{dx_{31}}{dt} \geq 0$ when $x_{31} = 0$. So x_{31} will be a positive state variable.

For the states, x_{30} , x_5 , x_{12} , x_{35} , x_{16} , x_{25} , x_{36} , and x_{37} positivity will be checked in the appendix.

Now we will check whether the other state variables are positive, and which restrictions will be found. When the expressions between the state variables are considered, it will be seen directly that when x_{30} , x_5 , x_{12} , x_{35} , x_{16} , x_{25} , x_{36} , and x_{37} are positive most other state variables are positive. The states that are also positive in this case are x_3 , x_4 , x_9 , x_{10} , x_{14} , x_{15} , x_{20} , and x_{29} . The states which have to be considered, because of restrictions, are x_6 , x_7 and x_8 , which depend on x_{36} , x_{11} , x_{21} , and x_{28} , which are the same, x_{17} , x_{18} , and x_{19} , which depend on x_{37} , and x_{24} , which depend on x_{25} .

When the expressions for x_6 , x_7 , and x_8 are considered, it is found that $x_{36} \in (0, 7.8000)$ has to hold. Thus when $x_{36} = 7.8000$, $\frac{dx_{36}}{dt}$ is less than or equal to zero. When $x_{36} = 7.8000$ it is found that $x_6 = 3.9$, $x_7 = 0$, and $x_8 = 0$. The following is then obtained for $\frac{dx_{36}}{dt}$:

$$\begin{aligned} \frac{dx_{36}}{dt} = & -24763.2481 \frac{x_1 u_2}{1 + 10 x_1} \\ & - 4011.3354 \frac{x_4^{1.2} u_4}{1 + 1.2689 x_4^{1.2}} \\ & - 43.5081 \frac{x_{14} u_8}{1 + 20 x_{12} + 0.6173 x_{14}} \\ & - 0.1083 \cdot 10^7 \frac{x_{13} u_{17}}{1 + 0.1961 x_{11} + 8.3333 x_{13}}. \end{aligned}$$

From this one can conclude that $\frac{dx_{36}}{dt} \leq 0$, which means that $x_{36} \in (0, 7.8000)$ is necessary for x_6 , x_7 , and x_8 to be positive state variables.

At the same way one can find that x_{37} has to be in $(0, 7.8000)$. This is the case, because $c_{11,2} \geq 0$ if $x_{37} \in (-0.5992, 9.8173)$ and by this also when $x_{37} = 7.8000$. To check whether the differential equation for x_{37} is less or equal to zero, both terms in the equation are considered, this is done in Appendix A.4. It can be seen that the numerator of the first term is equal to zero, which means that the whole term is zero. So the second term of the differential equation has to be zero. In the appendix one can see that this is indeed the case.

One can also find in Appendix A.4 that $\frac{dx_{25}}{dt} \leq 0$ if $x_{25} = 4$. So x_{24} is also a positive state, since $x_{24} = 4 - x_{25}$.

The only variables that have to be considered are x_{11} , x_{21} , and x_{28} , which are the same and can be expressed as

$$\begin{aligned} x_{11} = x_{21} = x_{28} &= 5.1600 - x_{31} - 0.0430x_{30} - 0.0860x_5 \\ &\quad - 0.0430x_{12} - 0.0430x_{36} = \\ &\quad 5.1600 - 0.0430 \left(\frac{x_{31}}{0.0430} + x_{30} + 2x_5 + x_{12} + x_{36} \right). \end{aligned}$$

Now first a function $f(x_{31}(t), x_{30}(t), x_5(t), x_{12}(t), x_{36}(t))$, denoted by f , will be defined as:

$$\begin{aligned} f(x_{31}(t), x_{30}(t), x_5(t), x_{12}(t), x_{36}(t)) &= \\ \frac{x_{31}(t)}{0.0430} + x_{30}(t) + 2x_5(t) + x_{12}(t) + x_{36}(t) \end{aligned}$$

When x_{11} is equal to zero, f has to be less than or equal to 120. So $\frac{df}{dt}$ has to be less than or equal to zero, if x_{11} is equal to 120. In Appendix A.4 one can find that this is indeed the case.

Now it can be concluded that the dynamical system for glycolysis of *Trypanosoma brucei* is a positive system. Also the output variables are positive, since they are in fact several of the state variables. In this section the methods of determination are discussed and a few determinations are done. Most of the determinations and calculations can be found in Appendix A.4.

4.3 Steady state

In the last two sections positivity is discussed and checked for glycolysis in *Trypanosoma brucei*. In this section the steady state property of a non-linear positive dynamical system will be discussed. First the concept of steady state and of equilibrium state will be explained, after this several definitions of the concepts will be given. Then something will be said about the difference between steady state and equilibrium state. Most of the definitions are taken

from, [28]. In this section also a few methods to compute or to determine a steady state will be discussed shortly.

Questions that arise are: does a steady state exist and if it exists, is it unique, and is it stable? If a a stable steady state exists is it asymptotically stable or globally asymptotically stable? At this moment it is impossible to answer all these questions for biochemical reaction networks with rate equations as defined in this report. First definitions for the above steady state properties will be provided, after which some ideas of these concepts will be discussed. Most of the ideas will come from the articles [23], [10] from E.D. Sontag and M. Feinberg.

In Section 4.6 the steady state will be determined numerically for the model of glycolysis in *Trypanosoma brucei*. The computer program Matlab is used to determine this steady state, by determining the state trajectory numerically, until a steady state is reached. This is done under aerobic and under anaerobic conditions. The steady state is determined numerically, since no method is available, at the moment, to calculate it analytically. Before determining the steady state for the model of glycolysis in *Trypanosoma brucei* the method in Matlab will be explained first.

4.4 Steady state properties of a dynamical system

The phenomenon of steady state will be explained first. For a time-invariant positive system with constant input variable, u_s , a steady state is a state, in which a systems state trajectory will remain, when it is initiated in this state or when it reaches this state. So the state vector does not change when the system is in steady state. By this the differential equation for the state, x_s in steady state, is equal to zero, $\frac{dx_s}{dt} = f(x(t), u_s) = 0$.

A steady state can be reached for the system when the input is the same for all times, this is called a steady input. In this case also the output becomes constant, y_s , then the system consists of steady input and steady output. When the input variables change, a new steady state will be reached after a while and when the input variables are depending on time, the system will never reach a steady state.

In the case that a system of differential equations is a system without any input variables, a state for which $\frac{dx_e}{dt} = f(x(t)) = 0$, is called an equilibrium state. This is the state in which the state trajectory will remain, when it is initialized at this state or when it reaches this state.

The following definition is a definition of an equilibrium state and a definition of a steady state of a positive system, which can be used for systems for biochemical reaction networks.

Definition 4.8 [28]

1. Consider the system

$$\dot{x}(t) = f(x(t)), \quad x(t_0) = x_0.$$

An equilibrium state of this system is a state $x_e \in \mathbb{R}_+^n$ such that the state trajectory will remain at this value when initialized with it; or, equivalently,

$$0 = f(x_e).$$

2. Consider the system

$$\dot{x}(t) = f(x(t), u(t)), \quad x(t_0) = x_0.$$

A steady state of this system for a fixed steady input $u_s \in \mathbb{R}_+^m$ is a state $x_s \in \mathbb{R}_+^n$ such that when the system is initialized at this value and the input function is identical to the steady input value, $u(t) = u_s$ for all $t \in [t_0, \infty)$, then the state trajectory will remain at this value forever; or, equivalently, if

$$0 = f(x_s, u_s).$$

So for the rational positive system as in Chapter 3.2, that is, for a cell reaction network a steady state is defined as follows:

Definition 4.9 [28] Consider the rational positive system,

$$\begin{aligned} \frac{dx}{dt} &= B \text{Diag}(r(x(t), x_{ex})) u(t), \quad x(t_0) = x_0, \\ y(t) &= H \text{Diag}(r(x(t), x_{ex})) u(t). \end{aligned}$$

A steady state of the system associated with the external concentration vector $x_{ex,s} \in \mathbb{R}_+^{n_{ex}}$, and constant input $u(t) = u_s \in \mathbb{R}_+^m$ for all $t \in [t_0, \infty)$, is a vector $x_s \in \mathbb{R}_+^n$ which is a solution of the steady state equation

$$0 = B \text{Diag}(r(x_s, x_{ex,s})) u_s.$$

The steady outflow rate corresponding to this steady state is then defined as,

$$z_s = H \text{Diag}(r(x_s, x_{ex,s})) u_s \in \mathbb{R}_+^{n_z}$$

It has to be remarked that the use of terms differs in mathematics and biology. A steady state and equilibrium state in mathematics, in this case control and system theory, is not the same as the corresponding terms in biology. An equilibrium state in biology for a biochemical reaction refers to the situation where the rate of the reaction is the same in both directions. When the system is in steady state, the pathway flux through the enzyme equals the rate at which the enzyme catalyzes the reaction [21]. So in steady state the rates will be constant but the bio-chemical substances can still change in concentration.

Several methods are available to calculate a steady state. One of these methods is simulation of the continuous time system, which will be discussed in the next section. In Section 4.6 the state trajectory will be determined, for the model for *Trypanosoma brucei*, until a steady state will be reached.

Another method is solving the system $0 = f(x(t), u(t))$, for example by Maple, Mathematica or Matlab. To do this, rational equations can be reduced to polynomial equations, this method is discussed below when existence of a steady state is discussed. Another method is a Newton-like recursion method. This method is based on finding the roots of a function $f(x)$. These are the values of x for which $f(x) = 0$. First one has to make an initial guess for the value of the root, denoted by x_0 . If this is not a root of the equation, $f(x_0 \neq 0)$, this guess can be improved, with $x_i = x_{i-1} - \frac{f(x_i)}{f'(x_i)}$, for $i = 1, 2, \dots$. One can stop when $f(x_i)$ is sufficient close to zero [5].

Now that it is known what is meant by steady state, existence and uniqueness of a steady state can be discussed, as well as the questions about stability, asymptotical and globally asymptotical stability. Before discussing these questions we will give some explanations about these concepts.

If a steady state exists then the equation $f(x, u_s) = 0$ has at least one solution. A steady state is unique if this equation has exactly one solution. So the following definition can be given for existence and uniqueness of a steady state:

Definition 4.10 *Consider the system with steady input value $u(t) = u_s \in \mathbb{R}_n^+$, $\forall t \in [t_0, \infty)$,*

$$\dot{x}(t) = f(x(t), u(t)), \quad x(t_0) = x_0.$$

A steady state exists for this system if the equation

$$0 = f(x_s, u_s)$$

has a solution, $x_s \in \mathbb{R}_+^m$. The steady state is unique if this equation has precisely one solution.

A method to check whether a steady state exists to solve $0 = f(x_s, u_s)$, for $x_s \in \mathbb{R}_+^n$ when $u_s \in \mathbb{R}_+^m$ is known. Recall that $f(x_s, u_s)$ is a function that consists of differences between rate equations, which are rational polynomial functions. A polynomial in n variables with positive coefficients is denoted by

$$p(x) = \sum_{k \in \mathbb{N}^n} c_p(k) x_j^{k(j)}.$$

One can rewrite the terms of the differential equations in such a way that they have the same denominator. So the following equation

$$\frac{p_1 - p_2}{q_1} - \frac{p_3 - p_4}{q_2} = 0$$

has to be solved. Here p_1, p_2, p_3, p_4, q_1 , and q_2 are polynomials that are contained in the rate equations. Then

$$\frac{p_1 - p_2}{q_1} - \frac{p_3 - p_4}{q_2} = 0 \quad \Leftrightarrow$$

$$\frac{(q_2(p_1 - p_2) - q_1(p_3 - p_4))}{q_1 q_2} = 0 \quad \Leftrightarrow$$

$$(q_2 p_1 + q_1 p_4) - (q_2 p_2 + q_1 p_3) = 0$$

For small problems it is possible to solve such an equation. When the degree of the polynomial becomes high, the problem of finding the roots of a polynomial becomes very difficult quickly [15].

For example, for the model of glycolysis of *Trypanosoma brucei* several numerators become polynomials of a degree of four or higher. Already then it would be a lot of work to solve this problems with an algorithm.

In [28] one can find an algorithm for computation of a steady state, which is based on first transforming the stoichiometric matrix, by row operations, and after this finding the roots of the numerator, when all terms were brought under the same denominator. In this paper also an algorithm is described for computing a steady state of a continuous-time linear positive system, in this case the matrix has to be irreducible.

This algorithm is based on first computing a permutation matrix, P , in such a way that the matrix PAP^T is in Frobenius form, see [4]. After this a reduced system is obtained and can be solved. The question one can ask is: whether it is possible to extend this algorithm to a system that consists of rational positive rate equations? This question is still an open question.

For the model of glycolysis in *Trypanosoma brucei* the graph is not irreducible, one can find the graph of this system of differential equations in the Appendix A.5.1. The graph of a dynamical system is described by the following definition.

Definition 4.11 *The graph of a dynamical system,*

$$\begin{aligned}\dot{x} &= f(x(t), u(t)), x(t_0) = x_0 \\ y(t) &= h(x(t), u(t)),\end{aligned}$$

is defined by a set of vertices V , also called nodes and a set of lines, the edges E , $G:=(V,E)$. The set of vertices consists of the state and output variables. The edge (i, k) is a directed edge from node k to node i , $k \rightarrow i$, if \dot{x}_i depends on x_k , or $h_i(x(t), u(t))$ depends on x_k .

The graph is irreducible if and only if the graph is strongly connected, which means that one can travel from every node to every other node of the graph. A graph is a network of nodes and vertices, which will be explained in Section 5.3 about control in more detail.

One can easily check that for the graph of the model of glycolysis in *Trypanosoma brucei* it is not possible to travel from every node in the graph to every other node in the graph. The graph consists of a directed connection of two strongly connected subgraphs.

Next, stability, asymptotic stability and global asymptotic stability will be discussed. A steady state for a dynamical system is stable if all trajectories nearby stay close to the steady state. So when the initial value of x , x_0 at time t_0 , is chosen close to the steady state value, the state $x(t)$ stays close to this value $\forall t \in [t_0, \infty)$. The following definition is a definition of stability of a steady state.

Definition 4.12 [28] *Consider the system*

$$\begin{aligned}\dot{x}(t) &= f(x(t), u(t)), x(t_0) = x_0, \\ y(t) &= h(x(t), u(t)).\end{aligned}$$

A steady state, $0 = f(x_s, u_s)$ and $y_s = h(x_s, u_s)$, is stable if

$$\forall \epsilon \in (0, \infty) \exists \delta \in (0, \infty) \text{ such that}$$

$$\|x_0 - x_s\| < \delta \Rightarrow \|x(t) - x_0\| < \epsilon \forall t \in [t_0, \infty).$$

A steady state is asymptotically stable if the steady state is stable and it is locally attractive. So there exists a neighborhood of the steady state for which the state trajectory when started inside this neighborhood will reach the steady state as a limit. A steady state is called globally asymptotically stable if every solution, for any choice of initial value in the domain, converges to the steady state.

Definition 4.13 [28] Consider the system

$$\begin{aligned}\dot{x}(t) &= f(x(t), u(t)), x(t_0) = x_0, \\ y(t) &= h(x(t), u(t)).\end{aligned}$$

1. A steady state, $0 = f(x_s, u_s)$ and $y_s = h(x_s, u_s)$, is asymptotically stable if it is stable and if

$$\exists \delta \in (0, \infty) \text{ such that if } \|x(0) - x_s\| \leq \delta \text{ then } \lim_{t \rightarrow \infty} x(t) = x_s \forall x_0 \in \mathbb{R}^n.$$

2. A steady state, $0 = f(x_s, u_s)$ and $y_s = h(x_s, u_s)$, is globally asymptotically stable if

$$\lim_{t \rightarrow \infty} x(t) = x_s \forall x_0 \in \mathbb{R}^n.$$

For a biochemical reaction system x_0 has to be at least in \mathbb{R}_+^n . For the model of glycolysis in *Trypanosoma brucei* the domain of the state variables, is determined in Section 4.2.

The class of systems which are discussed in this paper, are rational positive systems for biochemical reaction networks. At this moment no concrete method to calculate stability, asymptotically stability and globally stability are found. Below some results from the article [23], by E.D. Sontag [10], by M. Feinberg, and [28] are discussed.

In [23] results for existence of a unique equilibrium, asymptotical stability, global asymptotic stability of this equilibrium are determined for biochemical reaction networks. These results are restricted to systems of differential equations with mass action kinetics,

$$\dot{x} = \sum_{i=1}^m \sum_{j=1}^m a_{ij} x_1^{b_{1j}} x_2^{b_{2j}} \dots x_n^{b_{nj}} (b_i - b_j).$$

In this equation $A = (a_{ij})$ is the matrix that consists of the rate constants and B is the matrix with consists of the reaction vectors, as described in Chapter 3. The matrix A has to be irreducible and the matrix B has to be positive. In [23] a theorem is given which explains, for a positive class S , a unique equilibrium exists, that this is asymptotically stable and whether it is globally asymptotically stable [23, p.1032]. What is meant by a positive class S , is described in this article. The theorem is proved in detail. An open problem is the problem of extending the theory for the above system to systems that occur using Michaelis-Menten reaction kinetics.

In [10], by M. Feinberg, the Deficiency zero and Deficiency one Theorems are discussed. The kinetics that is used for this paper is mass action kinetics. The deficiency zero theorem is also discussed in other articles of M. Feinberg

and F.J.M Horn, see [8], [9], [11], and [14]. Before giving these theorems first theory from [10] will be described.

A reaction network has rank s if there exists a linearly independent set of s reaction vectors for the network and there exists no linearly independent set of $s + 1$ reaction vectors. The reaction vectors are of the form described in Chapter 3. So the rank of a network is the number of elements in the largest set of reaction vectors for the network, which is independent.

A linkage class is the set of complexes in a separate part of the network. So the number of linkage classes is the number of separated parts of which the network form. The number of linkage classes is denoted by l , while the number of complexes in the network is given by n .

For each reaction network the deficiency, denoted by δ , can be calculated, which is $\delta = n - l - s$. Positive dependence of the reaction vectors is necessary for the existence of a positive steady state and is, in fact, sufficient to ensure the existence of rate constants for which the corresponding mass action equations admit a positive steady state.

Most of the results of the Deficiency zero Theorem and the Deficiency one Theorem holds for the system

$$\dot{c} = \sum_{\mathcal{R}} \mathcal{K}_{i \rightarrow j}(c)(y_j - y_i), \quad c \in \mathbb{R}_+^N,$$

in which $\mathcal{K}_{i \rightarrow j}$ are the rate equations and \mathcal{R} denotes the set of reactions in the network. So the sum is taken of over all reactions $y_i \rightarrow y_j$. For the results the rate equations are mostly of mass action kinetics. For a few results it is not necessarily that the rate equations are of mass action kinetics.

The Deficiency zero theorem tells that for a reaction network, not necessarily mass action, when the network is weakly reversible, the differential equations for the corresponding reaction system cannot admit a positive steady state. If the network is not weakly reversible, the differential equations cannot admit a cyclic trajectory along which all species concentrations are positive. Now when the network is weakly reversible then, for mass action kinetics, the differential equations for the corresponding reaction system have the following properties: there exists within each positive stoichiometric compatibility class precisely one steady state, this steady state is asymptotically stable, and there is no nontrivial cyclic trajectory along which all species concentrations are positive.

The Deficiency one theorem considers a mass action system, of which the corresponding network consists of l linkage classes, each containing one terminal strong linkage class. Suppose that the deficiency of the network and the deficiencies of the individual linkage classes satisfy the following conditions: i) $\delta_\theta \leq 1$, $\theta = 1, 2, \dots, l$; ii) $\sum_{\theta=1}^l \delta_\theta = \delta$. Then, no matter what positive values the rate constants take, the corresponding differential equations can admit

no more than one steady state within a positive stoichiometric compatibility class. If the network is weakly reversible, the differential equations admit precisely one steady state in each positive stoichiometric compatibility class.

For the model of glycolysis in *Trypanosoma brucei*, as given in Appendix A.2, the deficiency is equal to zero, since the number of complexes is equal to 42, the number of linkage classes is 19 and the rank of the reaction network is equal to 23. The network of reaction equations as given in this appendix is not weakly reversibly. This means that the equations cannot admit a cyclic trajectory along which all species concentrations are positive. This part of the Deficiency zero Theorem holds for a reaction network, which is not necessarily for mass action kinetics.

The third part of the Deficiency zero Theorem and the Deficiency one theorem holds for reaction networks, which are of mass action kinetics. A question that can be asked is: how to extend this result for all reaction networks, not necessarily mass action kinetics? In particular how to extend to reaction network, of Michaelis-Menten reaction kinetics.

In [28], results are available to check stability for linear systems. Also some results are described, which make use of Lyapunov functions to determine if an equilibrium state of zero is stable, asymptotically stable.

4.5 Numeric determination of the steady state

In the following Section the steady states of the model of glycolysis in *Trypanosoma brucei* will be determined numerically, under aerobic and anaerobic conditions as well. This is done since no other practical method exists to determine the steady state analytical. A steady state of a dynamical system can be determined numerically with the help of Matlab, this will be described in this Section. The Matlab program will be given and the method used by Matlab will be discussed.

To determine a steady state in Matlab two files have to be made, one file consisting of the system of differential equations, and one file consisting of the program that solves the system and the program for plotting the state trajectory. The solver that is mostly used, and will be used to solve the model for glycolysis in *Trypanosoma brucei*, is ODE45. This solver solves non-stiff differential equations, with a medium-order method. This method is based on an explicit Rung-Kutta formula. This is a one-step solver to compute $y(t_n)$. This method uses the solution of the time point immediately before, $y(t_{n-1})$. The ODE45 solver is the best function for a variety of problems [27].

The Runge-Kutta method is an improved version of Euler's method. For a

differential equation $\frac{dy}{dt} = f(y(t))$ it holds that,

$$\begin{aligned} t_{k+1} &= t_k + \Delta t \\ y_{k+1} &= y_k + f(t_k, y_k) \Delta t. \end{aligned}$$

To calculate y_{k+1} from y_k the step that has to be taken in the Runge-Kutta method is

$$y_{k+1} = y_k + \left(\frac{m_k + 2n_k + 2q_k + p_k}{6} \right) \Delta t,$$

in which m_k , n_k , q_k , and p_k are four slopes that are given by the function $f(x(t))$. A weighted average is taken to calculate these slopes, where the slopes from \tilde{t} are weighted twice as heavy as the other slopes. To calculate these slopes intermediate variables are used. The slopes and the intermediate variables used in this method are

$$\begin{aligned} m_k &= f(t_k, y_k), \\ n_k &= f(\tilde{t}, \tilde{y}_k), & \tilde{t} &= t_k + \frac{\Delta t}{2}, & \tilde{y}_k &= y_k + m_k \frac{\Delta t}{2}, \\ q_k &= f(\hat{t}, \hat{y}_k), & \hat{y}_k &= y_k + n_k \frac{\Delta t}{2}, \\ p_k &= f(t_{k+1}, \bar{y}_k), & \bar{y}_k &= y_k + q_k \Delta t. \end{aligned}$$

So the Runge-Kutta method will also go halfway along the t-axis, while the Euler method does not. One can find the above description about the Runge-Kutta method in more detail in [5].

Now a system is said to be stiff when the solution of a system of differential equations contains components which change at significant different rates for given changes in the dependent variable. Whether a procedure that is applied to solve these systems has success depends on the eigenvalues of and in particular the ratio of the smallest and the largest eigenvalues [17].

To obtain this ratio, for a set of differential equations $\dot{x}(t) = f(x(t))$ the derivative has to be taken with respect to x , $\frac{df(x)}{dx}$. Next the value has to be inserted of the state at which one wants to obtain the derivative. Afterwards the eigenvalues have to be calculated, from which the eigenratio can be calculated as

$$\frac{|\lambda_{max}|}{|\lambda_{min}|},$$

with λ_{max} and λ_{min} , respectively, the largest and the smallest eigenvalue of the matrix described above.

Now to determine a steady state numerically with Matlab, first a function is needed that contains the right hand sides of the set of differential equations. This function can be made in a Matlab file. One have to define this function with 'function' and has to give it a name. So the function is the following:

```
function F='function name'(t,y)
'Set of differential equations and algebraical equations'
```

The name of the file is the same as the name of the function and will be used in the second file, for solving the system. For the example of *Trypanosoma brucei* y , will be denoted by x , since y is used as output vector.

In the second file one solves the system of differential equations given in the first file. The output of the solver is a column vector of time points, called T , and array with solutions, called Y . In Y each row corresponds to the solution at the corresponding time in the corresponding row in T . The code to solve the system is the following:

```
[t,y] = 'name solver'('function name','tspan','y0','options')
```

The name of the solver used in the following section is ODE45, but in Matlab one can find a number of other solvers.

As one can see in the function which solves the system a horizon has to be specified. This is the integration interval, $[t_0, t_f]$, t_0 is the initial time and t_f is the final time. The solver uses t_0 as initial time and integrates from this time to the final time. The solver returns a solution for every integration step, when one specified only the initial and the final time in this interval. When one specifies more time points, the solver will give only the solutions evaluated at the given time points. It can happen that a solver does not necessarily step precisely to a time point, which is given in the horizon. The solutions produced at the specified time points are of the same order of accuracy as the solutions computed at the internal time points. The time values must be in order, this order can be smaller or larger. The `tspan` can be given by

```
tSpan=['value t initial' 'value t final'];
```

One also has to specify the initial conditions for the set of differential equations, this is y_0 . This is a n vector of initial values at t_0 , with $n \in \mathbb{N}$ the number of unknown variables, also the number of differential equations.

```
yInitial=['y_1(0)';...;'y_n(0)'];
```

With the values in options, arguments can be given, such as for example for the relative error tolerance, 'RelTol' and for the absolute error tolerance 'AbsTol', one can find these in the Matlab manual. With the help of `odeplot` one can plot the solution of the solver, the state trajectory. One can tell from which trajectory, column, one wants to obtain a plot, and which part of the trajectory, columns.

```
plot(t,y('row','column'))
```

In the next section the above method will be used to determine the steady state for the model of glycolysis in *Trypanosoma brucei*, both under aerobic and under anaerobic conditions.

4.6 Steady state for the model of *Trypanosoma brucei*

In this section the steady state for the model of glycolysis in *Trypanosoma brucei* will be determined numerically. First the system of differential equations is converted from Maple to Matlab, this can be copied easily. The method described above is used to determine the steady state. The solver which is used in Matlab is ODE45, for non-stiff systems of differential equations.

As described in the above section, two Matlab files are obtained. The first file consists of a function called 'trypbruc'. This function first contains a list of input variables, with their values. Afterwards the set of differential equations is given in this function. With dx_i the differential equation $\frac{dx_i}{dt}$ is meant, for $i \in \{1, 30, 5, 31, 12, 35, 16, 25, 36, 37\}$. Then the vector F is the vector of differential equations of the system for glycolysis in *Trypanosoma brucei*. This function can be found in Appendix A.5.2. The name of the file has to be the 'function name'.m. So the name of this file is 'trypbruc.m'.

In Appendix A.5.2 the program which determines the steady state is given. First the time set is defined as $[tInitial, tFinal]$ in minutes. Then the initial value for the state variables has to be defined. This is the value at $t = 0$ and can be taken randomly in the domain of the system. Further the function name has to be given and options for the absolute and the relative tolerance. After this the method 'ode45' is applied to determine the steady state trajectory for the state variables, with given function, tSpan, Initial state values, and options. After this the steady state trajectory are plotted. To plot the commands subplot and plot are used. Finally this program gives the values of the state variables and the output variables at the final t value.

For the model of glycolysis in *Trypanosoma brucei* two different conditions are discussed. Glycolysis will take place under aerobic and under anaerobic conditions. Under aerobic conditions V_{max} for the enzyme GK is assumed to be zero, this means that the reaction from Gly-3-P into DHAP does not occur, see Figure 3.1. In the model in this report this results in u_{17} to be zero. Under anaerobic conditions the reaction catalyzed by GPO does not occur, V_{max} is equal to zero for this enzyme. So in this report u_{15} will be put to zero in this case in state of V_{max} .

Below a steady state will be determined for aerobic and anaerobic conditions, respectively. It will be seen that different steady state vectors will be reached for both cases.

As stated in the introduction of this section for aerobic conditions u_{17} is put to zero. The other input variables are equal to one, since the steady state of the complete model without adjustments is used. In Section 5.4, adjustments are applied on input variables to control the output of ATP.

The steady state has been determined, for several initial states. It is seen that for all possibilities tried the same steady state will be reached. So we conjecture that there exists a unique steady state, but we cannot prove this. When initial values are taken close to steady state, it is obtained that the system will reach steady state quicker than when initial values are taken far from steady state, this is as expected.

In Appendix A.5.2 results are denoted, in the form of figures, in which one can see how the state trajectories of the state variables will reach steady state. Figures of state trajectories are given for two different final times, namely 1 minute and 10 minutes. So one can see how a steady state will be reached. In the appendix one can find figures in which steady state is determined for the vector of initial values which is the 1 vector, $x_0 = [1, 1, 1, 1, 1, 1, 1, 1, 1, 1]$. Determinations of steady state with other initial values will not be given in the appendix of this report.

After one minute almost all states are at steady state or close to steady state and after 10 minutes all state variables except x_{16} have reached their steady state values. After 45 minutes also x_{16} has reached steady state.

Since under anaerobic conditions the reaction from Gly-3-P cannot take place, since oxygen is needed for this reaction, u_{15} is assumed to be zero. Under this condition Gly-3-P is converted into glycerol [2]. In Appendix ?? figures are plotted for the state trajectory, with initial value $x_0 = [1, 1, 1, 1, 1, 1, 1, 1, 1, 1]$, under anaerobic conditions. This is done for $t \in [0, 1]$ and for $t \in [0, 5]$ minutes. Already within two minutes a steady state is reached, which is much quicker than under aerobic conditions.

By use of the vector of initial values of $x_0 = [1, 1, 1, 1, 1, 1, 1, 1, 1, 1]$ the eigenratio is equal to 1789.0947 for the aerobic case, for the anaerobic case the eigenratio is equal to 247.7314. So under aerobic conditions the eigenratio is much higher than under anaerobic conditions, for this initial vector. This because of the difference between the largest and the smallest eigenvalue is large under aerobic conditions. This can be the reason, that it takes more time before the system reached steady state under aerobic conditions. Actually the method to determine the steady state works, despite the high eigenratio, which means that the system is probably stiff.

The steady state values that were found are very close to the steady state values determined, also numerically in [2] from which one can conclude that

the model is converted correctly. The relative difference is 0.0049, this is the Euclidean norm of the difference of both results divided by the results in this report. The relative difference under anaerobic conditions is 0.0306.

Sensitivity of the system with respect to the parameters can also be a problem. A system is called sensitive when a large change in steady state occurs, while the parameters have a small change. One is interested in $\frac{dx(t)}{dp_k}|_{x_s}$. This is not checked in this report.

In Table 4.1 one can find the results of the variables in steady state, for both the aerobic condition and the anaerobic condition. Here one can see that $x_6 = 0.7817$, $x_{17} = 2.8010$, $x_1 = 0.0561$, and $x_{16} = 21.4393$, under aerobic conditions. So in steady state the concentration of ATP in the glycosome is much smaller than the concentration in the cytosol. Also in relation to the concentration of ADP the concentration of ATP in the glycosome is much smaller than in the cytosol. The concentration of glucose inside the glycosome is low, namely 0.0561 *mM*.

Under anaerobic conditions $x_6 = 0.4071$, $x_{17} = 2.0329$, $x_1 = 0.1023$, and $x_{16} = 1.5760$. The concentration of glucose inside the glycosome, under anaerobic conditions, is about twice the concentration under aerobic conditions. So there is an increase of the glucose uptake from outside the cell. The concentration of ATP in the glycosome is almost the half of the concentration under aerobic conditions, this is not the case with the concentration of ATP in the cytosol under anaerobic conditions. But for both the relation ATP-ADP is lower under anaerobic conditions than under aerobic conditions. The concentration of pyruvate is much smaller under anaerobic conditions than under aerobic conditions. This because under aerobic conditions glucose was converted into pyruvate completely, while under anaerobic conditions both pyruvate and glycerol were produced, in equimolar amounts [2].

Table 4.1: the steady state concentrations under aerobic and anaerobic conditions

| State variable | Steady state concentration (mM) aerobic | Steady state concentration (mM) anaerobic |
|----------------|---|---|
| x_1 | 0.0561 | 0.1023 |
| x_6 | 0.7817 | 0.4071 |
| x_7 | 1.6251 | 1.3913 |
| x_{16} | 21.4393 | 1.5760 |
| x_{17} | 2.8010 | 2.0329 |
| x_{18} | 2.8010 | 1.4254 |
| x_{36} | 3.1884 | 2.2056 |
| x_{37} | 6.5570 | 5.4912 |

In this chapter dynamical system properties are discussed. First positivity of a rational positive system is discussed. In Section 4.2 positivity is obtained for the system of glycolysis in *Trypanosoma brucei*. Afterwards the steady state property is discussed in Section 4.4. In this section first the concept is explained, after this several methods to compute steady states are discussed. Also in this section questions about stability, asymptotical stability, and global asymptotical stability of a steady state are discussed. For this discussion several articles are used. Finally in Section 4.5 a method to determine a steady state trajectory of the state numerically by Matlab is described. In Section 4.6 this method is applied to the model of glycolysis in *Trypanosoma brucei*. Different results are obtained for aerobic and anaerobic conditions.

We saw that almost the same results are reached as in [2], which means that the model is converted correctly.

Chapter 5

Control of Dynamical Systems

This chapter deals with control of dynamical systems. Motivations for this subject are problems that arise in drug design, food processing, waste water treatment, and other biotechnology. Control theory can be used in this context. The problem is how to develop effective medicines and to improve food production. In this chapter we successively discuss the motivation in more detail, the problems, and the approaches. Finally one of these approaches is discussed in more detail.

5.1 Motivation

In this section control of dynamical systems for biochemical reaction networks will be motivated. There are several areas in which control is useful. Two of these areas are the area of developing medicines and the area of biotechnology.

Medicines or drugs are synthesized in a process referred to as drug design. A good drug has the desired effect combined with as little side effects as possible. To achieve this objective control theory can be used. The question is how to determine the input to reach a particular output. Medicines are developed in the pharmaceutical industry by several companies. Examples of companies that develop medicines are Duphar, in Weesp, and Orgenon, in Oss, in the Netherlands.

The approach used for drug design is to determine chemical substances that inhibit one or more enzymes in a virus, parasite, bacterium or a micro-organism with the goal disabling this organism. It is difficult to choose target enzymes that will inhibit the organism but not the host in which the organism is located. Furthermore, one cannot always predict how inhibiting

one enzyme effects the complete network. In the next section approaches of control of biochemical models for biochemical reaction networks, especially control for drug design, will be discussed.

Another area where control is useful is that of food production in biotechnology. For example one can think on yeast, which is used for brewing beer and for bread dough. Control of the circumstances is desirable to obtain optimal growth of biomass and to work most efficiently to reduce costs, [26]. One wants to control the production by influencing the micro-organism to increase the production rate. An example of a company that works with this kind of food production is Gist Brocades, in Delft, the Netherlands.

An idea is to make mathematical models for these problems, and to apply control theory to these models. For drug design this approach is called network-based drug design or model-based drug design. Problems are, how to determine medicines which work effectively and, for food production, how to control the models in such a way that the amount of biomass grows optimally. To apply control theory to these problems one has to define the goals first. These are the so called control objectives.

The general problem is therefore how to influence a biochemical reaction network to achieve the desired control objectives. An example of a control objective is putting particular outflows zero by changing the input trajectory. In Section 5.3 this will be explained and in Section 5.4 this will be applied to the model of glycolysis in *Trypanosoma brucei*. Another control objective is changing the input trajectory, to increase particular outflows. This is not discussed in this paper.

5.2 Problems and approaches

In this section we want to explain problems to control a specific output, by controlling the input vector. This goal is to obtain a specific output variable or for a specific output variable to become zero by putting one or more input variables equal to zero. The latter control problem can be used for drug design.

After discussing a few problems four approaches will be discussed to solve the control problem for drug design. Also the advantages and disadvantages of these four approaches will be described. The approaches that will be discussed in this section are: 1) the method of simulation of the steady state when putting one or a combination of several input variables equal to zero, randomly; 2) metabolic control theory; 3) control design via abstraction and graph algorithms; 4) control theory for zeroing outputs.

The next section concerns rational drug design. We want to focus on the approach to control design that uses graph algorithms, because this approach

is applied in this paper to the model of glycolysis in *Trypanosoma brucei*.

The problems discussed in the last section are problems of control of biochemical reaction systems. One is interested to know how to adjust the input trajectory, to determine a particular output variable. So actually what we want is to control the output variables by changing the input variables. We want to develop an efficient method to control the output, an algorithm called a control law which tells us how to control the output. We need to determine an input trajectory, such that one or several control objectives, which are the outputs to be controlled, are satisfied.

As mentioned above Rational drug design, for finding medicines against a virus, parasite, bacterium or a micro-organism, is in overall based on disabling the organism. To do this one wants to inhibit one or more enzymes in the virus. The input trajectory can be a trajectory, which depends on the state variables and the output variables, which are time dependent. While in the problem for drug design discussed in this report one or more of the input variables are set to zero, and by this these variables do not depend on time. So for the first problem $u(t) = g(x(t), y(t))$ is obtained and for the second problem $u_i(t) \equiv 0$, for some $i \in 1, \dots, n, \forall t \in [t_0, \infty)$.

In this section four of methods for rational drug design will be discussed. One of these methods will be used for the example glycolysis in *Trypanosoma brucei* in this report. For this reason the next section will focus on this method. However we will discuss the four approaches to rational drug design first.

1) The first approach is the method of simulation. To apply this method one has to put one or more input variables to zero and then simulate the output trajectory for example with Matlab, Maple or Mathematica. Then one can conclude from the simulation what is happening with the output variables of interest. In fact this is simply a method of trial and error.

When the number of different input variables is equal to $m \in \mathbb{N}$, first one can start to put one of the input variables equal to zero. After this one can do the same for two input variables. So when $u \in \mathbb{R}_+^m$ then 2^m possibilities arise and this is practically too complex for huge dynamical systems. For small dynamical systems this method is easy to use, since for $u_i = 0$, for some $i \in 1, \dots, n, \forall t \in [t_0, \infty)$ it is easy to determine the steady state of such a system and the steady outflows as well.

A disadvantage of this method is that it is unclear how to select $\{u_i = 0, i \in I \subset \mathbb{Z}_m\}$. For this reason the amount of possibilities rises very quickly, since it is equal to 2^m . A method mentioned later, uses a way to determine $I \subseteq \mathbb{Z}_m$ more efficiently and uses simulation afterwards to check verification of the control objective. This way of working saves computation time, but also makes use of the same simulation method.

2) A second method to control specific output variables for drug design is metabolic control theory. Metabolic control theory is based on the question which step in the biochemical reaction network limits the steady state flux. The idea of metabolic control theory is to see whether the change of activity of an enzyme i has an effect on the steady state flux. The flux when the system is in state is called J .

So suppose changes in an external parameter of the system provide a change in a local rate v_i . When the enzyme is isolated, what is then the corresponding effect on the system flux J , when the enzyme is present in the whole system, [7]? In metabolic control theory one wants to understand regulation of metabolic networks by the genetic network.

The results of metabolic control analysis gives information about the effect on the flux by inhibition of an individual enzyme. Enzymes are not isolated in the reaction system: they interact through the metabolite concentrations. So inhibition of an enzyme in a pathway may result in an increase of the concentration of its substrates and/or a decrease of the concentration of its products.

Next metabolic control theory will be described. The information about metabolic control is obtained from the mini review 'Metabolic control analysis of glycolysis in trypanosomes as an approach to improve selectivity and effectiveness of drugs' by B. Bakker et al [3], and from chapter 12 of the book 'Fundamentals of Enzyme Kinetic' by Athel Cornish-Bowden [7]. Afterwards advantages and disadvantages of this method will be discussed. Finally results of metabolic control theory on the model of glycolysis in *Trypanosoma brucei* will be discussed briefly.

Metabolic control analysis is one of the methods to analyze the behavior of metabolic systems. Metabolic control theory was first published by Kacser and Burns (1973) and Heinrich and Rapoport (1974). The flux control coefficient is used to determine the effect of the state flux, due to a change of enzyme activity of a particular enzyme rate. The rate of an enzyme is a local property of the system because it refers to an enzyme which is isolated from the reaction network. The fluxes of the system in steady state and metabolic concentrations in networks are called system properties [7].

The flux control coefficient, denoted by C_i^J of an enzyme i is defined as the relative change of the enzyme activity, r_i , that is responsible for this change in flux at constant activities of all other enzymes.

These definitions of a flux control coefficient now allow for a precise statement of the circumstances in which an enzyme could be said to catalyze the rate-limiting step of a pathway. Such a description would be reasonable if any variation in the activity of the enzyme produced a proportional variation in the flux through the pathway and in terms of equations this would mean that such an enzyme had $C_i^J = 1$. Mathematically the flux control

coefficient is described as follows:

$$C_i^J = \frac{\left(\frac{\partial \ln J}{\partial \ln p}\right)_{ss}}{\frac{\partial \ln v_i}{\partial \ln p}} = \frac{v}{J} \cdot \frac{\left(\frac{\partial J}{\partial p}\right)_{ss}}{\frac{\partial v_i}{\partial p}}.$$

In this equation p is a parameter, which for example can be an inhibitor concentration, which affects the activity of enzyme i specifically. The partial differentials are taken for the flux and for the rate of the reaction catalyzed by enzyme i with respect to p .

When an enzyme has a flux control coefficient equal to 1, this enzyme is the rate limiting factor for the whole reaction network. If an enzyme has a flux control coefficient of 0, the rate for the reaction that is catalyzed by this enzyme is not rate limiting at all. For reaction networks it is possible to find the control coefficient experimentally. Values that are possible are values between 0 and 1.

In an ideal pathway for biochemical reactions the sum of the flux control coefficients of all enzymes is equal to 1: $\sum_{i=1}^m C_i^J = 1$, here $m \in \mathbb{N}$ is the total number of enzymes. So when one of the enzymes has a high flux control coefficient, the others must have low control coefficients and vice versa, [3].

The theory above describes the use of metabolic control theory to answer the question which enzymes is the most effective to reach a specific output variable. So metabolic control theory can be used as an approach to rational drug design. This method is easy to compute and it is an effective method at steady state values. To use this method one calculates the derivative of the flux in steady state with respect to p . This means that $\frac{\partial J}{\partial p}$ is calculated in (u_s, x_s, y_s) . So this metabolic control coefficient is a local criterium that holds only in a small neighborhood of (u_s, x_s, y_s) . At different steady state values the Jacobians can be different. To overcome this, the Jacobians have to be computed at several steady state values. This requires more computations, which means additional work.

In her thesis B. Bakker has asked the question: what controls glycolysis in *Trypanosoma brucei*. In Section 5.3 we will discuss this question for the third method, the following method to be described. In Section 5.4 this method will be described for the glycolysis in *Trypanosoma brucei*.

3) The third approach to rational drug design is the approach applied as an example on the model of glycolysis in *Trypanosoma brucei*. In this section this method is discussed briefly.

The method of control design by abstraction and graph algorithms, makes use of the graph of the biochemical network associated to the dynamical system. The next section describes how the graph of the network is determined. This will be done with the help of the reaction network and the rate equations belonging to this network.

The nodes of the graph are the state variables of the system and the outflow variables. The problem of rational drug design is equivalent to determining a cut set in the graph. A cut set is a set of edges such that when removed from the graph, no path from inflow to outflow exists. So after having the graph, first the cut set method is used to delete edges corresponding with the inputs that have to become zero.

After applying the cut set method, one has to check if there still exists a path from inflow to outflow. This method can be used to determine which input variable, or variables one has to put to zero for zeroing the outflow. The outflow is zero when there does not exist a path from inflow to outflow. The simulation method described above can be used to check whether the outflow variables indeed become zero.

Now the possibilities to put input variables zero are less for simulation, then when this method is used from the beginning. This method is useful because the abstraction of the graph, in this case the graph, is easy to compute. It is also useful that there are algorithms available for computing cut sets. An algorithm for computing cut sets is discussed in the following section. Another advantage of this method is that it does not depend on numerical values of parameters, which are not always estimated correctly or reliably.

A disadvantages of this method is the fact that the graph has to be defined by the modeler. This can be difficult when the system is large. In this case the graph can be divided into subgraphs. But even then the modeler has to define the subgraphs and implement them in a computer program like Maple, this method is very laborious. Another disadvantage of this approach is the computational complexity of algorithms for finding a cut set.

4) The fourth approach described in this paper is the method of mathematical control theory for zeroing outputs. Assume that the following dynamical system exists:

$$\begin{aligned}\dot{x} &= f(x(t), u(t)), \\ z(t) &= h(x(t), u(t)).\end{aligned}$$

This method is based on zeroing specific outflow variables to solve the following equation:

$$0 = h(x(t), g(x(t))),$$

where $g(x(t))$ is the input function, which depends on the state vector of the system. So one has to search for a state vector, x , for which the output function, h , becomes zero.

Actually, the systems discussed in this paper, are rational positive systems. At this moment there is no control and system theory available. There exist

contributions to control of bilinear, polynomial systems, and linear positive systems in the area of control and system theory. This should be seen in contrast to metabolic control theory, where methods are available to control specific objectives of a rational positive system.

In article [23] of Eduardo D. Sontag, several results are explained for regularity under assumption of a particular hypothesis, denoted by H_k . These results are given for dynamical systems of chemical networks, restricting the attention of ‘mass action kinetics’,

$$\dot{x} = \sum_{i=1}^m \sum_{j=1}^m a_{ij} x_1^{b_{1j}} x_2^{b_{2j}} \dots x_n^{b_{nj}} (b_i - b_j).$$

In that article it is remarked that most of the results in that article can be applied to Michaelis-Menten kind reactions of the form:

$$r = V^+ \frac{\frac{[S]}{K_s}}{1 + \frac{[S]}{K_s}}.$$

But to extend this method to Michaelis-Menten rate equations consisting of more than one substrate is difficult as it is mostly not possible to write the set of differential equations in the form above. One has to think about a way to extend the theory in this article to dynamical systems of chemical networks to Michaelis-Menten reaction kinetics. We do not know whether this is possible at the moment. So the approach of using system theory to zeroing the output is not possible at the moment. Theory in the area of control theory has to be developed for this problem.

In this section four of the approaches to rational drug design have been discussed. The method in this paper for the glycolysis in *Trypanosoma brucei* is the third method: control design via abstraction and application graph algorithm. In the next section control to rational drug design will be described in more detail.

5.3 Control for rational drug design

In this section the graph theoretic method for control to rational drug design will be discussed in more detail. In the next section this method will be applied to the model of glycolysis in *Trypanosoma brucei*. This method makes use of the graph of the biochemical network. Afterwards the cut set method is applied to this graph. This method is described below in this section. If a cut set has been determined then it can be verified that there does not exist a path between inflow and outflow. Finally results will be checked with the help of simulation of a new steady state.

The problem for which the following procedure is an approach is the problem of rational drug design described in Section 5.2. The control objective is to zero one or more particular output variables. The problem is which input variables to put to zero, to zero pre specified output variables. So the goal is to control the output variables by changing the input variables.

First a graph will be described for the biochemical network of interest. A graph is a set of objects, which are called vertices and edges. The vertices are connected by arrows which are called edges, which can be directed or undirected. A graph can now be described by a set of vertices, denoted by V and a set of unordered or ordered pairs of distinct edges, denoted by E . Usually the sets E and V are finite sets. An undirected graph G can be described by the pair $G := (V, E)$. A directed graph G is an ordered pair $G := (V, E)$ with V a set of vertices and E a set of ordered pairs of vertices, which are called directed edges. An edge $e = (x, y)$ is directed from node x to node y [12]. The following two examples are examples of an undirected and of a directed graph.

Example 5.1 *This is an example of a directed graph. The edges between the vertices do not have any direction. The set of vertices V and the set of edges E are*

$$V = \{1, 2, 3, 4, 5, 6\},$$

$$E = \{\{1, 2\}, \{1, 5\}, \{2, 3\}, \{2, 5\}, \{3, 4\}, \{4, 5\}, \{4, 6\}\}.$$

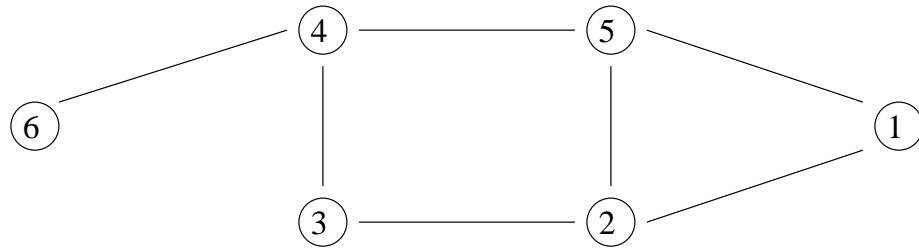

Figure 5.2: an example of a undirected graph.

Example 5.2 The graph below is an example of a directed graph. Between some vertices there is an edge in both directions. The sets of vertices V and the set of edges E are

$$V = \{1, 2, 3, 4, 5, 6\},$$

$$E = \{\{3, 2\}, \{2, 1\}, \{5, 2\}, \{3, 4\}, \{4, 3\}, \{1, 5\}, \{5, 1\}, \{4, 5\}, \{6, 4\}\}.$$

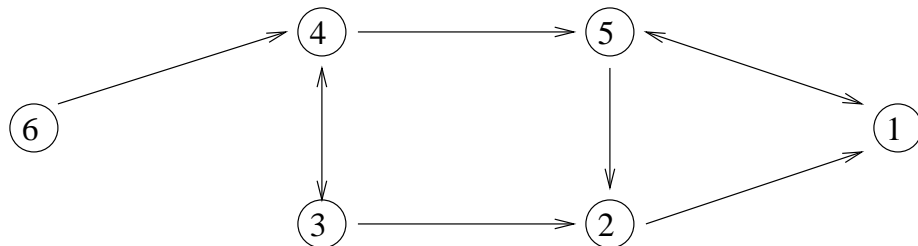

Figure 5.2: an example of a directed graph.

A dynamical system of a biochemical reaction network can be converted in a graph. The graph of the system

$$\dot{x}(t) = B \cdot \text{Diag}(r(x(t), x_{ex}(t)))u(t),$$

$$y(t) = H \cdot \text{Diag}(r(x(t), x_{ex}(t)))u(t),$$

as used in this approach will be explained now. The nodes of the graph are the state variables of the system, the complexes of state variables and the outflow variables.

A edge from one reaction complex, i , to another, complex j exists if there exists a biochemical reaction which consumes complex i and produces complex j , $i \rightarrow j$. There exists a dotted edge from a state or output variable to a complex if the state or output variable is one of the substrates or products in the complex. Furthermore a dotted edge exists if a complex is produced and after this one of the products will be a consumer for a next reaction there is an edge from the complete complex to that particular product.

So edge (i, k) , $k \rightarrow i$ exists if either there exists a reaction from complex k to complex i , or k is part of complex i and the complex is consumed or i is part of the complex k and i is consumed after production of the complex k . Here $i, k \in I$, which is the set of nodes. The edges in the graph are labelled by u_i , $i = 1, \dots, 21$, the input variables of the reactions catalyzed by the enzymes. The graph described above is different from the graph of the system, which is described in Section 4.4.

If a path in the graph exists from the inflow to an output variable of interest it is possible to produce this output variable. When there does not exist a

path from the inflow to the output variable the output variable will be zero. So when a particular input variable is put to zero some edges will be deleted. The question is which inputs to put to zero for zeroing a particular output. We will see below that this problem is equivalent to determining a cut set in the graph.

For the example of glycolysis in *Trypanosoma brucei* this is not so useful, because for this example the problem can be solved directly from the graph as will shown below in Section 5.4. Actually, solving the problem directly from the graph means checking all possibilities. When the model is large this takes a lot of computation time. But the computation time for checking if a path exists is less than the time it takes to simulate every possibility.

Now the cut set method will be described.

Definition 5.3 *An edge-colored directed graph is a tuple (V, E, C) consisting a set of vertices, V , a set of directed edges $E \subseteq V \times V$, and a set of colors $C = \{c_1, \dots, c_p\}$. Each edge is assigned a color of the set C and by E_i the set of edges having color $c_i \in C$ is denoted. For any subset $I \subseteq C$ denote $E_I = \cup_{i \in I} E_i$. If $v_0, v_1 \in V$ and if there exists a path from vertex v_0 to vertex v_1 in the graph, then call $I \subseteq C$ a colored cut-set if in the new graph $(V, E \setminus E_I, C)$ there does not exist a path from v_0 to v_1 .*

Note that the graph of a reaction scheme can be considered as an edge-colored directed graph where the colors correspond to the different enzyme concentrations or, equivalently, the input components u_i for $i \in I \subseteq \mathbb{Z}_m$.

Problem 5.4 *The minimal colored cut-set problem.*

Consider an edge-colored directed graph (V, E, C) and two vertices $v_0, v_1 \in V$ for which there exists a path from vertex v_0 to vertex v_1 in the graph. Determine for these vertices a colored cut-set $I^ \subseteq C$ such that for any other colored cut-set $I \subseteq C$ for the same vertices the following inequality holds: $|I^*| \leq |I|$. Here $|I|$ denotes the size of the cut-set $I \subseteq C$.*

The problem above is a generalization of the minimum cut-set and the minimum multi-cut-set problem discussed in [1, 4.1.3]. In a multi-cut-set problem there are not two initial and terminal vertices but two subsets of vertices: one for the initial and one for the terminal vertices. From the above mentioned association of the graph of a reaction network with an edge-colored directed graph it follows that instances of the main problem can be converted into instances of Problem 5.4. The minimal sensor selection problem and a problem for communicating decentralized diagnoses can also be converted in the latter problem, see [19].

For the following discussion the reader has to be informed about the theory of computation and complexity as developed in mathematics and computer

science. Logicians and computer scientists specify the computation of problems in terms of a *Turing machine*. A problem is then termed *decidable* if any instance of the problem when programmed on a Turing machine will halt after a finite number of steps. See the book [22] for the full story. If a problem is decidable then it is of interest to know how the computation time depends on the problem parameters. The time is specified in terms of the order of the steps needed and classified in terms of classes. One such class is $\text{dtime}(t(n))$ which refers to the a time of order $O(t(n))$ on a deterministic Turing machine. Recall that one writes that $f(n) \in O(g(n))$ where $f, g : \mathbb{N} \rightarrow \mathbb{R}_+$ if there exist $c, n_0 \in \mathbb{Z}$ such that for all $n \geq n_0$, $f(n) < g(n)$. Below the case of $\text{dtime}(n^{\text{polylog } n})$ is used where $\text{polylog } n$ stands for $\log^k(n)$ for a $k \in \mathbb{Z}_+$. For example, for $k = 2$, $\text{polylog } n = \log \log n$.

Definition 5.5 Consider a minimization problem P , optimal solution map $S^* : P \rightarrow \mathbb{R}$, and an approximation algorithm $A : P \rightarrow \mathbb{R}$.

Call A an r -approximate algorithm, with $r \in \mathbb{Q}$, if

$$\frac{A(p)}{S^*(p)} \leq r, \quad \forall p \in P.$$

For concepts and theory on approximation and on the computation of combinatorial optimization problems see the book [1].

Theorem 5.6 Problem 5.4 admits no $2^{\log^{1-\epsilon} n}$ approximations for any $\epsilon \in (0, \infty)$ unless $\text{NP} \subseteq \text{dtime}(n^{\text{polylog } n})$.

See [18] for the proof of this theorem. It is believed that the inclusion relation of the theorem does not hold but currently there is no proof for this. The lower bound is considered to be a very poor lower bound. For algorithms to approximate the solution of a minimal colored cut-set problem, see the paper [20].

The conclusion of the discussion above is that the problem of determining a subset of enzymes to inhibit so as to cut the production of a particular chemical compound is of very high complexity. But for particular instances of the problem the computation may not be that large as is the case for the example of *Trypanosoma brucei*.

The method described above is a method to find a subset of the input variables, which have to be put to zero, to zero the output variable of interest. This method will be checked by the method of simulation. Put in the Matlab program described in Section 4.4 these particular input variables equal to zero and determine the state trajectory numerically, until a steady state is reached.

In the next section control design for glycolysis in *Trypanosoma brucei* will be discussed. The results of this method will also be compared with the results of metabolic control theory.

5.4 Control design for glycolysis in *Trypanosoma brucei*

As has been mentioned, *Trypanosoma brucei* is a unicellular, eukaryotic parasite. It causes the African sleeping disease. Most people that suffer from this disease will die if the infection is untreated. When *Trypanosomes* live in the bloodstream of humans its supply of ATP depends on glycolysis only. So when glycolysis cannot take place, *Trypanosoma brucei* do not have any energy supply. Because of this, the pathway of glycolysis can be important for rational drug design. The purpose of this section is zeroing the ATP concentration in the glycosome and the ATP concentration in the cytosol. The idea is to do this by zeroing one or more input variables. So the problem is which input variable, or variables to put zero to zero the ATP concentrations under aerobic and anaerobic conditions.

To reach this objective the graph theoretical method will be used. First a graph of the system has to be made. Using the above described method. In Maple a program will be used which determines if there exists a path from a given starting point to a given end point. In this paper we determine if a path from glucose outside the cell to ATP in the glycosome or to ATP in the cytosol exists. In the Maple program, input variables can be adjusted to zero. This can be done by hand or by trying all combinations using another program, denoted in the appendix. This way one or more input variables can be set to zero. After putting input variables equal to zero, one can determine if there still exists a path still exists from glucose to ATP. In this paper we will see that it is enough for the model of glycolysis in *Trypanosoma brucei* to do this for only one or two input variables. The program will also give the existing path from glucose to ATP in the glycosome or to ATP in the cytosol.

When it is known that there does not exist a path from glucose to ATP in the glycosome and in the cytosol, the steady state will be determined numerically with Matlab. Here the same method is used as in Section 4.5. After plotting the state trajectory it is checked whether the concentration of ATP in the glycosome and in the cytosol becomes zero. We will see what happens with the concentration of glucose in the cytosol and the concentration of pyruvate, for example.

The edges of the reaction equations are labelled by the input variables in such a way that when these particular input variables are put to zero, the edges have to be deleted. This can be done with a Maple program. For the glycolysis of *Trypanosoma brucei* it is not very difficult to determine the graph, but for very large systems this can be a problem.

The graph obtained for this method consists of 52 complexes, which are the nodes, consisting of 30 species in total. The number of edges is 117. An edge

can be labelled by more than one input variable. Below a part of the first part of the graph will be described shortly. One can find the list of nodes and the list of edges in Appendix A.6.1 In this appendix also the complete graph is given.

Glucose outside the cell is transported to the inside of the glycosome from the glycosome outside the cell. Thus an edge exists from S_2 , which is glucose outside the cell to S_1 , which is glucose inside the cell. These edges are labelled by the input variable u_1 , which belongs to a glucose transporter. So when u_1 is zero no path exists between S_2 and S_1 . The following reaction is the reaction of glucose in the glycosome with ATP to Glc-6-P and ADP, catalyzed by the enzyme hexokinase. First dotted edges from S_1 and S_6 to S_1 are added, since the products S_1 and S_6 is used as substrates for the complex $S_1 + S_6$. Afterwards an edge is added from the complex $S_1 + S_6$ to the complex $S_3 + S_7$. This edge and this dotted edge are labelled by input variable u_2 , which belongs to hexokinase.

Below the Maple programs to determine whether a path in this graph exists between glucose and ATP will be described. First the program in general and after that the program for the model of *Trypanosoma brucei* will be described. One can find the program in Appendix A.6.2.

In Maple, the ‘networks’ and ‘linalg’ packages are used. The package networks is needed for using graph theory and the linalg package is used for linear algebra. First a function is made, which is called ‘PathExists’, with parameters G , the graph, v_1 the begin node and v_2 the end node. In this function first the set of different sets of components of the graph will be made. So a set of sets, denoted by C will be returned. A path from v_1 to v_2 exists when both nodes are in the same component set, denoted by c . With the command ‘member’ it can be checked if $v_1 \in c$. The function ‘PathExists’ is the same for every graph.

In the next function, the main function, the graph of the system as defined in this section has to be adjusted in the case that one or several input variables are set to zero. Before doing this the graph has to be defined. The input vector is the parameter of this function, denoted by U . So this vector has to be given by applying the function. Then, with the help of if-statements, the graph is adjusted. In these statements it is specified which edge or edges have to be deleted when a particular input variable is equal to zero. After changing the graph a shortest path tree T can be made of the new graph, the command ‘shortpathtree’ is used for this. Finally for T is checked if there exists a path from v_1 to v_2 . When a path exists, this path will be determined and printed. Otherwise it will be printed that no path exists.

A graph can be defined with the command ‘new(Gf)’, where Gf is the name of the graph. In the model of *Trypanosoma brucei*, this can be cho-

sen freely. With the command ‘addvertex(,Gf)’ vertices can be added. For the model of glycolysis in *Trypanosoma brucei* there are 52 vertices. By ‘addedge([],names=[],Gf)’ edges can be added, 116 in the case of *Trypanosoma brucei*. If wanted, one can specify names for the edges. The list of vertices and edges of the appendix is used to define the graph in Maple.

Finally the functions ‘FindPath’ are determined. First FindPath1 is a function, that sets one of the input variables equal to zero and then determines if a path exists. Then it returns a vector k , with $k_i = 0$ if no path exists if $u_i = 0$ and $k_i = 1$ if there still exists a path if $u_i = 0$. In the example of *Trypanosoma brucei* $i = 1, \dots, 21 \in \{1, 2, \dots, 21\}$.

In FindPath2 combinations of two input variables will be set to zero. When $k_i = 0$ for a particular i it means that when $u_i = 0$ no path exists from the input node to the output node. This means that for every combination of two input variables set to zero that contains this particular u_i , the result will be that no path exists. So only combinations are taken for which both k_i and k_j , $i, j \in \{1, \dots, 21\}$. This way combinations of input variables to be put zero are found.

This can also be done for three or more combinations. These functions are not given in the appendix, since for the model of glycolysis in *Trypanosoma brucei* it produces no extra combinations of u_i to put to zero. Actually, for this method the amount of possibilities can become large. So for large systems it is better to use the cut set method described in the last section.

Now the method described above is applied under aerobic and under anaerobic conditions. First u_{17} is assumed to be zero and afterwards u_{15} is assumed zero. For the model of glycolysis in *Trypanosoma brucei* 21 input variables are available. First one of the input variables is put to zero, and subsequently this two or more input variables are put to zero.

Under aerobic conditions, where besides u_{17} only one of the input variables $u_1, u_2, u_3, u_4, u_5, u_7$ or u_8 is put to zero or combinations of variables, consisting of one of these variables, no path exists from glucose to ATP in the glycosome. This can also be seen in the graph directly, since the graph of this particular system is synoptic. When combinations of two enzymes are put to zero, which do contain one of the above input variables, no extra possibilities occur. When $u_1, u_2, u_3, u_4, u_5, u_7, u_8, u_9, u_{10}$, or u_{11} are equal to zero no path exists from glucose to ATP in the cytosol. Thus when $u_1, u_2, u_3, u_4, u_5, u_7$ or u_8 are zero, there exists no path to both ATP in the glycosome and ATP in the cytosol.

For the anaerobic case, $u_{15} = 0$ is set to zero. Now when u_1, u_2, u_3, u_4 or u_5 is set to zero, no path exists from glucose in the glycosome to glucose in the cytosol. For combinations of setting to zero different input variables no path exists from glucose to ATP in the glycosome when both u_6 and u_7 are equal to zero or when both u_8 and u_9 are zero. When $u_1, u_2, u_3, u_4, u_5, u_7$,

u_8 , u_9 , u_{10} , or u_{11} is zero no path exists from glucose to ATP in the cytosol. So when u_1 , u_2 , u_3 , u_4 or u_5 is zero no path exists for glucose to ATP in the glycosome and ATP in the cytosol.

It is expected that for these input variables or combinations of two input variables, when they are set to zero, no path exists and the steady state of ATP in the glycosome and the steady state for ATP in the cytosol. To check this the steady state is determined numerically with the help of Matlab. The method of Section 4.5 is used to compute this.

Under aerobic conditions the steady state variables will be determined for the case that u_1 is zero, so the glucose transport from inside to outside the cell and vice-versa is blocked. For the case that u_4 is equal to zero, the reaction from Fru-6-P and ATP to Fru-1,6-BP and ADP is blocked. For the anaerobic case the steady state will be determined for the case that u_1 is set to zero and for the case that both u_6 and u_7 are zero. Since no rate equation exists for the reaction catalyzed by TIM, only u_7 has to be set zero, besides u_{15} . The initial vector is chosen as $[1, 1, 1, 1, 1, 1, 1, 1, 1, 1]$. It is also an idea to choose this vector as a vector of state variables, when one is interested in how the steady state is changes.

The steady state values are given in Tables A.6.2 and A.6.3. The following two tables are tables of the output variables of interest and state variables that are involved in the reaction that is blocked.

Table 5.1: the steady state concentrations under aerobic conditions.

| State variable | steady state conc. (mM) aerobic | Steady state conc. (mM) aerobic ($u_1 = 0$) | Steady state conc. (mM) aerobic ($u_4 = 0$) |
|----------------|---------------------------------|---|---|
| x_1 | 0.0561 | 0.0000 | 4.9994 |
| x_3 | 0.4411 | 0.0000 | 93.0232 |
| x_4 | 0.1279 | 0.0000 | 26.9767 |
| x_5 | 25.7975 | 14.8155 | 0.0000 |
| x_6 | 0.7817 | 3.9000 | 0.0000 |
| x_7 | 1.6251 | 0.0000 | 0.0000 |
| x_{12} | 0.0280 | 108.2661 | 0.0000 |
| x_{16} | 21.4393 | 0.0000 | 0.0000 |
| x_{17} | 2.8010 | 0.0000 | 0.0000 |
| x_{18} | 2.8010 | 0.0001 | 0.0000 |
| x_{36} | 3.1884 | 7.8000 | 0.0000 |
| x_{37} | 6.5570 | 0.0000 | 0.0000 |

Under aerobic conditions, when u_1 is zero, it took some minutes until a steady state was reached. In this case x_1 , which is the concentration of glucose in the cell, became zero. This is expected, since the glucose transporter is inhibited by putting x_1 equal to zero. The differential equation $\frac{dx}{dt}$ will depend only on input variable u_2 now. The only reaction which takes place with glucose as its product is the reaction from glucose to Glc-6-P. In the case that only u_1 is zero, x_3 and x_4 also become zero. A strong decrease in x_5 is obtained, from 25.7975 *mM* to 0.0843 *mM*. So putting u_1 zero does not only effect x_1 but the other reactions too.

The steady state variable that is obtained for x_{12} is unusually high, while the steady state values of x_{14} , x_{15} , and x_{16} are lower when $u_1 = 0$ as before, so accumulation of x_{12} takes place. I can not directly explain this result, since $\frac{dx_{12}}{dt}$ consists of u_7 and u_8 and not of u_1 . However, it may be explained biologically. This point has to be discussed with biologists. It can be seen that when u_1 is zero, the steady state of the output variables x_6 become 3.9 *mM* and the steady state for x_{17} became zero. This is as expected from the graph theoretical point of view, since x_{36} became 7.8 *mM* and x_{37} became zero. So the output variable x_6 will not become zero.

When besides u_{17} only u_4 is set to zero x_1 will become almost 5 *mM*. This is almost the same as the glucose concentration outside the cell in steady state. Accumulation of x_3 and x_4 , which are the Glc-6-P and the Fru-6-P concentrations respectively, can be obtained. This is as expected since Fru-1,6-BP production is inhibited. The output concentrations x_6 and x_{17} became zero, which is what we want. In steady state the concentration of pyruvate in the cytosol will becomes zero, so no pyruvate is available. Also,

most of the other state variables became zero.

Table 5.2: the steady state concentrations under anaerobic conditions.

| State variable | steady state conc. (mM) anaerobic | Steady state conc. (mM) anaerobic ($u_1 = 0$) | Steady state conc. (mM) anaerobic ($u_7 = 0$) |
|----------------|-----------------------------------|---|---|
| x_1 | 0.1024 | 0.0000 | 4.9987 |
| x_5 | 2.3466 | 0.8670 | 14.6774 |
| x_6 | 0.4071 | 3.9000 | 0.0000 |
| x_7 | 1.3913 | 0.0000 | 0.0020 |
| x_{10} | 0.0275 | 0.0233 | 0.1731 |
| x_{12} | 0.0097 | 0.5463 | 0.0000 |
| x_{16} | 1.5760 | 0.0000 | 0.0000 |
| x_{17} | 2.0329 | 0.0000 | 0.0000 |
| x_{18} | 1.4252 | 0.0192 | 0.0000 |
| x_{36} | 2.2056 | 7.8000 | 0.0002 |
| x_{37} | 5.4912 | 0.0193 | 0.0000 |

Under anaerobic conditions when, besides u_{15} also u_1 is set to zero, the glucose concentration in the glycosome will become zero, which is expected. The output concentration x_6 , which is ATP in the glycosome, will become 3.9 *mM* while x_{17} became 0. So the output x_6 will not become zero. Now when u_7 is set to zero, an increase in the concentration of GA-3-P in the cytosol, x_{10} is found while a decrease is found for the concentration of 1,3-BPGA, x_{12} , this as expected. Furthermore, the output variables x_6 and x_{17} will both become zero. Also, the concentration of pyruvate in the cytosol is zero in steady state.

Above we discussed the graph theoretical method to control the output variable ATP. Afterwards simulation was used to check whether the ATP concentration became zero indeed. In several cases this was the case. However, when u_1 is set to zero the steady state concentration for ATP in the glycosome became 3.9 *mM*. Also, some for me unexpected results occurred. Further research is needed to understand these results. It is useful to discuss this with biologists.

Actually it is more plausible for drug design to inhibit more enzymes, entirely or partly. One also has to consider the glycolysis of the host of *Trypanosoma brucei* and concentrate at the differences. So for the results above it is necessary to compare the results with results of glycolysis in humans and to discuss the results with biologists. Mathematically, every possibility to put input variables zero is possible, but biologically this is not the case. We have seen in this chapter that further research is also needed for the other methods which can be used to calculate or determine the steady state of a rational positive system.

Another area of research for drug design is changing input variables to increase the output variables or to reach a particular value for one or more output variables. I did not discuss this problem in this report. An idea is to solve this problem with the same kind of methods as the problem of zeroing one or more output variables.

Chapter 6

Conclusions

This chapter discusses the results and the main question of this report shortly. Furthermore several questions are mentioned. The aim of the project is development of control theory for biochemical reaction networks. For the model of glycolysis in *Trypanosoma brucei* development of control theory with respect to drug design is of special interest. For this purpose we want to set one or several input variables equal to zero, such that the output variable ATP will become zero. The main ideas have been mentioned in Chapter 5. Before discussing the main questions first a dynamical system is formulated in Chapter 3, and the system properties, positivity of the system and steady state of the system are discussed in Chapter 4.

In this report the model of glycolysis from [2] is converted to a dynamical system, as defined in system theory in Chapter 3. The biochemical model consists of 19 classes of reaction equations, 32 chemical species, and the number of complexes is 42. Reaction vectors are determined for these complexes, as defined in [10] by M. Feinberg. The dynamic system consists of 21 input variables, 37 state variables and 6 output variables. Most of the state variables are concentrations in the glycosome and in the cytosol, but there are also several state variables which consist in the mitochondrion or which are external concentrations. The complete system consists of 10 differential equations, including rate equations and a set of algebraic equations, which are moiety-conservation relations, equations for pools of species, and equilibrium equations.

For the model of glycolysis in *Trypanosoma brucei* all the state variables are expressed in the ten state variables, for which a differential equation is obtained. After this the system of differential equations can be rewritten in a system of ten differential equations, with ten unknown state variables. Finally, the output variables are discussed. These are the concentrations of species which are produced, but not consumed, and of the species of interest. The last are for the model of glycolysis ATP in the glycosome and ATP in

the cytosol.

It is not completely clear whether the system is easier to solve after reduction of state variables. Actually, when the states of the differential equations are found, the other states can be easily determined with the help of the algebraic equations from the known state variables. This holds for the model of glycolysis of *Trypanosoma brucei*, but does not hold for every dynamical system for a cell reaction network. The system cannot always be reduced to a set of k differential equations in k unknowns.

In Chapter 4 two dynamical system properties are discussed, positivity of the system and the property of steady state. First the condition positivity is explained. Afterwards this is checked for the model of glycolysis in *Trypanosoma brucei*. It turned out that the state set of the dynamical system obtained for this model is positive, but also consists of several upper boundaries. The state variables x_{36} and x_{37} , which stand for $[P]_g$ and $[P]_c$, respectively, have to be in $(0, 7.8000)$ both, since x_6 , x_7 , x_8 , x_{17} , x_{18} , and x_{19} have to be positive. The state variable x_{25} has to be less than or equal to 4, for x_{24} to be positive. The sum $\frac{x_{31}}{0.0430} + x_{30} + 2x_5 + x_{12} + x_{36}$ has to be less or equal to 120, for x_{11} , x_{21} , and x_{28} to be positive. It turned out that this is the case.

In Section 4.3 the property steady state is explained first. Several methods are discussed to determine a steady state. These methods are solving the equation $f(x, u) = 0$, determining the steady state numerically with the help of computer programs as Maple, Matlab, or Mathematica, using a Newton-like recursion method and finding the roots of the system in an algebraic way. Most of the methods work very well for linear systems, but for nonlinear systems, such as the system for glycolysis in *Trypanosoma brucei* it is difficult.

For the method to determine the roots of the system, the differential equations had to be converted in equations with one denominator the numerators became very large and difficult to solve. For the example of glycolysis of *Trypanosoma brucei* the trajectories of the states are determined numerically, until a steady state is reached. The same steady state values are found as in [2], but to determine the whole state trajectories with the computer program Matlab took more time than expected for several choices of initial values.

Further in this section the phenomenons stability, asymptotical stability, and global asymptotic stability were discussed. For rational positive systems no direct solution exist to determine this phenomenons for positive rational systems, but theory is available about methods for linear systems and for systems of biochemical reaction networks, which consist of mass-action kinetics, in state of Michaelis-Menten reaction kinetics.

One of the methods for a linear system makes use of irreducibility of the

graph of a linear positive system, [30]. Apart from the fact that the system for glycolysis in *Trypanosoma brucei* is not linear, the graph of the system is not irreducible as well. In [23] and [10], by respectively, E.D. Sontag and M. Feinberg, results were shown for systems of biochemical reaction kinetics, consisting of mass-action kinetics. In [10] the Deficiency zero and Deficiency one Theorems are formulated. In this report it is checked that the deficiency of the biochemical network for glycolysis in *Trypanosoma brucei* is of deficiency zero. An idea for further research, can be to extend the results in these articles to positive rational systems, or to prove whether this is possible.

Finally in Chapter 5, control of dynamical systems is discussed. Motivations of control of dynamical systems can be found in the area of biotechnology and in the area of drug design. In this report we focussed on control of dynamical system, with respect to drug design. The main research question is how: to control one or several of the output variables by controlling one or more input variables? First four approaches to solve this question are discussed. These are: 1) the method of simulation of the steady state, when putting random one or combinations of input variables equal to zero; 2) metabolic control theory; 3) control design via abstraction and graph algorithms; 4) control theory for zeroing outputs. The third method is explained in detail, the other methods are mentioned shortly.

The first method is a good method to determine a steady state, since it is relatively easy to simulate a steady state when one or more input variables are changed, but the number of possibilities to put one of several input variables zero is large. For the second method metabolic control coefficients have to be calculated. This is relatively easy. Since the control coefficients hold in the neighborhood of a steady state, the Jacobian can be different at different steady state values. The third method is applied on the model of glycolysis of *Trypanosoma brucei* in Section 5.4. One of the disadvantages of this method is the fact that the graph has to be defined by the modeler. This can be difficult when the system becomes large. Another disadvantage is the complexity of the cut set algorithm, which is explained in Section 5.3. The fourth approach is the approach of control theory for drug design. Several results are available for linear positive systems or for dynamical systems for biochemical reaction networks consisting of mass-action kinetics. To discuss this last result [23] is used.

In Section 5.3 control design via abstraction and graph algorithms is discussed in more detail. The aim is zeroing one or more output variables by zeroing one or more input variables. In this section the cut set method explained.

This method is in Section 5.4 applied on the system of glycolysis in *Trypanosoma brucei*. First a graph of the system has to be made, how to do this is explained in this section. Afterwards one or several of the input va-

riables are put to zero and determined if a path exists between the chosen input and output variables. It turned out that it is enough to do this for putting only one input variable equal to zero or two input variables. The results under aerobic conditions are different from the result of anaerobic conditions. When no path exist from input variable to output variable simulation is used to check whether indeed the ATP concentration became zero. In several cases this was the case. But when u_1 is set to zero the steady state concentration for ATP in the glycosome became 3.9 *mM*. Also some unexpected results occur. Further research is needed to understand these results. It is useful to discuss this with biologists.

As a conclusion several input variables are found, for which the ATP concentration becomes zero, when putting one of these input variables zero. It is known now which input variables to put zero, to zero the output variable ATP. But one cannot always conclude this directly by only using the graph theoretical method, simulation has to be used also.

To give a correct answer on the main question more research is needed, namely for the results of control of ATP it is necessary to compare these results with results of glycolysis in host cells. In the area of control more research and discussions with biologists are needed. Another area of research for drug design is changing input variables to increase the output variables, or to reach a particular value for one or more output variables. I did not discuss this problem in the report. An idea to solve this problem is to use the same kind of methods as the problem of zeroing one or more output variables.

Appendix A

Glycolysis of Trypanosoma Brucei

A.1 Introduction

In this appendix of my report, ‘Modelling and Control, of Glycolysis in Trypanosoma brucei’, the results of the model of glycolysis in Trypanosoma brucei are given. These results are explained in the report itself, in which I refer to this appendix.

The main problem of my research is development of control theory for biochemical reaction networks, in particular due to rational drug design.

In Section A.2 the biochemical model is formulated for glycolysis in Trypanosoma brucei. The mathematical model, such as used in dynamical system theory is determined in Section A.3. In this section first notations are denoted, afterwards the differential equations, and the algebraic equations are discussed. After this reduction of state variables is applied and the system after reduction of state variables is denoted. Finally the output variables are determined.

In the following two sections, respectively, the system property positivity is checked and the steady state is determined for the dynamical system of glycolysis in Trypanosoma brucei. This is done in Section A.4. In Section A.5 first the graph of the system will be determined in Subsection A.5.1. In Subsection A.5.2 the steady state will be determined numerically. First the Matlab programs are denoted in this subsection and afterwards the steady state results are denoted in tables and figures, for both the aerobic case and the anaerobic case.

The last section, Section A.6 is about control of the output variable ATP. A graph theoretical method is applied for zeroing the ATP concentration. In Subsection A.6.1 the graph, as used for the method, is formulated, and

in Subsection A.6.2 the Maple program is denoted for the graph theoretic approach, which is discussed in my report. In Subsection A.6.3 results of determining the steady state numerically, after setting several input variables equal to zero, are denoted in two tables, one for the steady state under aerobic conditions, and one for the steady state under anaerobic conditions.

In Section B a list of all equations of which the dynamical system for glycolysis in *Trypanosoma brucei* consists is denoted, and in Section C a list of abbreviations is denoted.

A.2 Biochemical model

In Chapter 3 a biochemical model is made for glycolysis in *Trypanosoma brucei*, this is done in Section 3.2. The model consist of a network of biochemical reaction equations. The molecules that occur in the network are the species, and the complexes are the total of molecules that occur on both side of a biochemical reactions.

The following network of biochemical reaction equations is considered for the glycolysis in *Trypanosoma brucei*:

1. $\text{Glc}_{ex} \longleftrightarrow \text{Glc}_c \longleftrightarrow \text{Glc}_g$
2. $\text{Glc}_g + \text{ATP}_g \longrightarrow \text{Glc-6-P}_g + \text{ADP}_g$
3. $\text{Glc-6-P}_g \longleftrightarrow \text{Fru-6-P}_g$
4. $\text{Fru-6-P}_g + \text{ATP}_g \longrightarrow \text{Fru-1,6-BP}_g + \text{ADP}_g$
5. $\text{Fru-1,6-BP}_g \longleftrightarrow \text{DHAP}_g + \text{GA-3-P}_g$
6. $\text{DHAP}_g \longleftrightarrow \text{GA-3-P}_g$
7. $\text{GA-3-P}_g + \text{NAD}_g^+ \longleftrightarrow \text{1,3-BPGA}_g + \text{NADH}_g$
8. $\text{1,3-BPGA}_g + \text{ADP}_g \longleftrightarrow \text{3-PGA}_g + \text{ATP}_g$
9. $\text{3-PGA}_g \longleftrightarrow \text{3-PGA}_c \longleftrightarrow \text{2-PGA}_c \longleftrightarrow \text{PEP}_c$
10. $\text{PEP}_c + \text{ADP}_c \longrightarrow \text{Pyruvate}_c + \text{ATP}_c$
11. $\text{Pyruvate}_c \longrightarrow \text{Pyruvate}_{ex}$
12. $\text{DHAP}_g + \text{NADH}_g \longleftrightarrow \text{Gly-3-P}_g + \text{NAD}_g^+$
13. $\text{DHAP}_c + \text{Gly-3-P}_g \longleftrightarrow \text{DHAP}_g + \text{Gly-3-P}_c$
14. $\text{Gly-3-P}_c + \frac{1}{2} \text{O}_{2m} \longleftrightarrow \text{DHAP}_c + \text{H}_2\text{O}_m$
15. $\text{Gly-3-P}_g + \text{ADP}_g \longleftrightarrow \text{Glycerol}_g + \text{ATP}_g$
16. $\text{Glycerol}_g \longleftrightarrow \text{Glycerol}_c \longleftrightarrow \text{Glycerol}_{ex}$
17. $\text{ATP}_c \longleftrightarrow \text{ADP}_c + \text{P}_c$
18. $2 \text{ADP}_g \longleftrightarrow \text{ATP}_g + \text{AMP}_g$
19. $2 \text{ADP}_c \longleftrightarrow \text{ATP}_c + \text{AMP}_c$

The chemical species considered in [2] are:

| | | | | | |
|----------|---|-----------------------|----------|---|------------------------|
| S_1 | = | Glc_g | S_{21} | = | Gly-3-P_c |
| S_2 | = | Glc_{ex} | S_{22} | = | H_2O_m |
| S_3 | = | Glc-6-P_g | S_{23} | = | O_{2m} |
| S_4 | = | Fru-6-P_g | S_{24} | = | NAD^+_g |
| S_5 | = | Fru-1,6-BP_g | S_{25} | = | NADH_g |
| S_6 | = | ATP_g | S_{26} | = | Glycerol_{ex} |
| S_7 | = | ADP_g | S_{27} | = | Pyruvate_{ex} |
| S_8 | = | AMP_g | S_{28} | = | Gly-3-P |
| S_9 | = | DHAP_g | S_{29} | = | DHAP |
| S_{10} | = | GA-3-P_g | S_{30} | = | Hexose-P_g |
| S_{11} | = | Gly-3-P_g | S_{31} | = | Triose-P |
| S_{12} | = | $1,3\text{-BPGA}_g$ | S_{32} | = | 3-PGA_c |
| S_{13} | = | Glycerol_g | S_{33} | = | 3-PGA |
| S_{14} | = | 3-PGA_g | S_{34} | = | 2-PGA_c |
| S_{15} | = | PEP_c | S_{35} | = | N |
| S_{16} | = | Pyruvate_c | S_{36} | = | P_g |
| S_{17} | = | ATP_c | S_{37} | = | P_c |
| S_{18} | = | ADP_c | S_{38} | = | Glc_c |
| S_{19} | = | AMP_c | S_{39} | = | Glycerol_c |
| S_{20} | = | DHAP_c | | | |

Now the network of biochemical reaction networks can be rewritten as follows:

1. $S_2 \longleftrightarrow S_{38} \longleftrightarrow S_1$
2. $S_2 + S_6 \longrightarrow S_3 + S_7$
3. $S_3 \longleftrightarrow S_4$
4. $S_4 + S_6 \longrightarrow S_5 + S_7$
5. $S_5 \longleftrightarrow S_9 + S_{10}$
6. $S_9 \longleftrightarrow S_{10}$
7. $S_{10} + S_{24} \longleftrightarrow S_{12} + S_{25}$
8. $S_{12} + S_7 \longleftrightarrow S_{14} + S_6$
9. $S_{14} \longleftrightarrow S_{32} \longleftrightarrow S_{34} \longleftrightarrow S_{15}$
10. $S_{15} + S_{18} \longrightarrow S_{16} + S_{17}$
11. $S_{16} \longrightarrow S_{27}$

12. $S_9 + S_{25} \longleftrightarrow S_{11} + S_{24}$
13. $S_{20} + S_{11} \longleftrightarrow S_9 + S_{21}$
14. $S_{21} + \frac{1}{2}S_{23} \longleftrightarrow S_{20} + S_{22}$
15. $S_{11} + S_7 \longleftrightarrow S_{13} + S_6$
16. $S_{13} \longleftrightarrow S_{39} \longleftrightarrow S_{26}$
17. $S_{17} \longleftrightarrow S_{18} + S_{37}$
18. $2S_7 \longleftrightarrow S_6 + S_8$
19. $2S_{18} \longleftrightarrow S_{17} + S_{19}$

The set of species considered in this network is

$$S = \{S_1, \dots, S_{27}, S_{32}, S_{34}, S_{37}, S_{38}, S_{39}\}.$$

The number of species, n , is equal to 32 in the example of *Trypanosoma brucei*.

The set of complexes for this network is

$$\begin{aligned} C = \{ & S_2, S_{38}, S_1, S_2 + S_6, S_3 + S_7, S_3, S_4, S_4 + S_6, S_5 + S_7, \\ & S_5, S_9 + S_{10}, S_9, S_{10}, S_{10} + S_{24}, S_{12} + S_{25}, S_{12} + S_7, \\ & S_{14} + S_6, S_{14}, S_{32}, S_{34}, S_{15}, S_{15} + S_{18}, S_{16} + S_{17}, \\ & S_{16}, S_{27}, S_9 + S_{25}, S_{11} + S_{24}, S_{20} + S_{11}, S_9 + S_{21}, \\ & S_{21} + \frac{1}{2}S_{23}, S_{20} + S_{22}, S_{11} + S_7, S_{13} + S_6, S_{13}, \\ & S_{39}, S_{26}, S_{17}, S_{18} + S_{37}, 2S_7, S_6 + S_8, 2S_{18}, S_{17} + S_{19}\}. \end{aligned}$$

The number of complexes, m , is equal to 42 for the glycolysis in *Trypanosoma brucei*.

There are in total 42 reaction equation considered for this example. From these equations 19 of them are reversible, this gives 38 reaction equations, and 4 of the equations are irreversible. The number of different parts of the network is 19, these parts are called linkage classes, as described in Section 3.1.

As discussed in Section 3.2 the reaction vectors of this network can be determined. The stoichiometric coefficient of all the species, that plays a role in the specific reaction is denoted in the reaction vector. For each reaction equation a reaction vector is obtained. Note that when the reaction equation is reversible the reaction vectors are dependent. With b_i the reaction vector of reaction i is denoted for $i = 1, \dots, 42$.

Reaction vectors:

$$b_1 = e_{38} - e_2$$

$$b_2 = e_2 - e_{38}$$

$$b_3 = e_1 - e_{38}$$

$$b_4 = e_{38} - e_1$$

$$b_5 = e_7 + e_3 - e_2 - e_6$$

$$b_6 = e_4 - e_3$$

$$b_7 = e_3 - e_4$$

$$b_8 = e_7 + e_5 - e_4 - e_6$$

$$b_9 = e_9 + e_{10} - e_5$$

$$b_{10} = -e_9 - e_{10} + e_5$$

$$b_{11} = e_{10} - e_9$$

$$b_{12} = e_9 - e_{10}$$

$$b_{13} = e_{10} + e_{24} - e_{12} - e_{25}$$

$$b_{14} = -e_{10} - e_{24} + e_{12} + e_{25}$$

$$b_{15} = e_{14} + e_6 - e_{12} - e_7$$

$$b_{16} = e_{12} + e_7 - e_{14} - e_6$$

$$b_{17} = e_{32} - e_{14}$$

$$b_{18} = e_{14} - e_{32}$$

$$b_{19} = e_{34} - e_{32}$$

$$b_{20} = e_{32} - e_{34}$$

Reaction vectors continued:

$$\begin{aligned}b_{21} &= e_{15} - e_{34} \\b_{22} &= e_{34} - e_{15} \\b_{23} &= e_{16} + e_{17} - e_{15} - e_{18} \\b_{24} &= e_{27} - e_{16} \\b_{25} &= e_{11} + e_{24} - e_9 - e_{25} \\b_{26} &= e_9 + e_{25} - e_{24} - e_{11} \\b_{27} &= e_{21} + e_9 - e_{11} - e_{20} \\b_{28} &= e_{11} + e_{20} - e_9 - e_{21} \\b_{29} &= e_{20} + e_{22} - \frac{1}{2}e_{23} - e_{21} \\b_{30} &= \frac{1}{2}e_{23} + e_{21} - e_{20} - e_{22} \\b_{31} &= e_{13} + e_6 - e_7 - e_{11} \\b_{32} &= e_{11} + e_7 - e_6 - e_{13} \\b_{33} &= e_{39} - e_{13} \\b_{34} &= e_{13} - e_{39} \\b_{35} &= e_{26} - e_{39} \\b_{36} &= e_{39} - e_{26} \\b_{37} &= e_{18} + e_{37} - e_{17} \\b_{38} &= e_{17} - e_{18} - e_{37} \\b_{39} &= e_6 + e_8 - 2e_7 \\b_{40} &= 2e_7 - e_6 - e_8 \\b_{41} &= e_{17} + e_{19} - 2e_{18} \\b_{42} &= 2e_{18} - e_{19} - e_{17}\end{aligned}$$

The deficiency of the network as discussed in [10], of M. Feinberg, and in Section 4.4, is equal to zero, since the number of complexes is equal to 42, the number of linkage classes is 19 and the rank of the reaction network is equal to 23.

A.3 Mathematical model

In this section the mathematical model of the biochemical reaction network of *Trypanosoma brucei* will be formulated. First several notations will be given. After this the rate equations, the differential equations and the algebraic equations are defined. The dynamical system is a reformulated system of the mathematical model in [2].

A.3.1 Notations, definitions, terminology

List of notations used in the equations:

$$\begin{aligned} t &= \text{total,} \\ en &= \text{enzyme,} \\ ex &= \text{extern,} \\ g &= \text{glycosomal,} \\ c &= \text{cytosolic,} \\ m &= \text{mitochondrial,} \\ u_i &= \text{input variable belonging to rate } i, u_i : T \rightarrow \mathbb{R}_+ \forall i \in \mathbb{Z}_{21}, \\ x_i &= \text{concentration of chemical substance } i, \\ u &= \begin{pmatrix} u_1 \\ \vdots \\ u_{21} \end{pmatrix} \in \mathbb{R}_+^{N_{en}} = \mathbb{R}_+^{21}, N_{en} = 21, \text{ and} \\ x &= \begin{pmatrix} x_1 \\ \vdots \\ x_{37} \end{pmatrix} \in \mathbb{R}_+^{37}, N = 37. \end{aligned}$$

List of functions which represent the input variables, represent the enzyme concentrations:

- u_1 = Transport of glucose across the plasma membrane.
- u_2 = HK
- u_3 = PGI
- u_4 = PFK
- u_5 = ALD
- u_6 = TIM
- u_7 = GAPDH
- u_8 = PGK
- u_9 = PGM
- u_{10} = ENO
- u_{11} = PYK
- u_{12} = Pyruvate transport across the plasma membrane.
- u_{13} = GDH
- u_{14} = Transport of Gly-3-P across the glycosomal membrane.
- u_{15} = GPO
- u_{16} = Transport of DHAP across the glycosomal membrane.
- u_{17} = GK
- u_{18} = Transport of glycerol across the glycosomal membrane and the plasma membrane.
- u_{19} = ATP utilization.
- u_{20} = Glycosomal AK.
- u_{21} = Cytosolic AK.

List of functions which represent the states of the system, in particular, the concentrations of chemical substances:

| | | | | | |
|----------|---|-------------------------|----------|---|--------------------------|
| x_1 | = | $[\text{Glc}]_g$ | x_{20} | = | $[\text{DHAP}]_c$ |
| x_2 | = | $[\text{Glc}]_{ex}$ | x_{21} | = | $[\text{Gly-3-P}]_c$ |
| x_3 | = | $[\text{Glc-6-P}]_g$ | x_{22} | = | $[\text{H}_2\text{O}]_m$ |
| x_4 | = | $[\text{Fru-6-P}]_g$ | x_{23} | = | $[\text{O}_2]_m$ |
| x_5 | = | $[\text{Fru-1,6-BP}]_g$ | x_{24} | = | $[\text{NAD}^+]_g$ |
| x_6 | = | $[\text{ATP}]_g$ | x_{25} | = | $[\text{NADH}]_g$ |
| x_7 | = | $[\text{ADP}]_g$ | x_{26} | = | $[\text{Glycerol}]_{ex}$ |
| x_8 | = | $[\text{AMP}]_g$ | x_{27} | = | $[\text{Pyruvate}]_{ex}$ |
| x_9 | = | $[\text{DHAP}]_g$ | x_{28} | = | $[\text{Gly-3-P}]$ |
| x_{10} | = | $[\text{GA-3-P}]_g$ | x_{29} | = | $[\text{DHAP}]$ |
| x_{11} | = | $[\text{Gly-3-P}]_g$ | x_{30} | = | $[\text{Hexose-P}]_g$ |
| x_{12} | = | $[\text{1,3-BPGA}]_g$ | x_{31} | = | $[\text{Triose-P}]$ |
| x_{13} | = | $[\text{Glycerol}]_g$ | x_{32} | = | $[\text{3-PGA}]_c$ |
| x_{14} | = | $[\text{3-PGA}]_g$ | x_{33} | = | $[\text{3-PGA}]$ |
| x_{15} | = | $[\text{PEP}]_c$ | x_{34} | = | $[\text{2-PGA}]_c$ |
| x_{16} | = | $[\text{Pyruvate}]_c$ | x_{35} | = | $[\text{N}]$ |
| x_{17} | = | $[\text{ATP}]_c$ | x_{36} | = | $[\text{P}]_g$ |
| x_{18} | = | $[\text{ADP}]_c$ | x_{37} | = | $[\text{P}]_c$ |
| x_{19} | = | $[\text{AMP}]_c$ | | | |

List of concentrations in

- the glycosome:
 $x_1, x_3, x_4, x_5, x_6, x_7, x_8, x_9, x_{10}, x_{11}, x_{12}, x_{13}, x_{14}, x_{24}, x_{25}, x_{30}$ and x_{36} ;
- the cytosol:
 $x_{15}, x_{16}, x_{17}, x_{18}, x_{19}, x_{20}, x_{21}, x_{32}, x_{34}$ and x_{37} ;
- the mitochondrion:
 x_{22} and x_{23} ;
- extern:
 x_2, x_{26} and x_{27} ;
- overall (in glycosome, cytosol and total):
 x_{28}, x_{29} and x_{33} ;
- average concentration over glycosome and cytosol:
 x_{31} and x_{35} .

Number of state variables of the biochemical reaction network:

$37 - 3 = 34$. Here x_2, x_{26} and x_{27} are exclude, because they are external concentrations.

A.3.2 Rate equations

In this subsection the rate equations for the reaction network are denoted. Most of the rate equations are of Michaelis-Menten kinetic. For several reaction equations no rate equation is available, because these equations are assumed to be in equilibrium. The rate equations are denoted by r_i , for $i \in \{1, 2, 4, 5, 7, 8, 11, 12, 13, 15, 17, 19\}$, where r_i corresponds with the input variable u_i . In this report the enzyme rate v in $nmol\ min^{-1}(mg\ cell\ protein)^{-1}$ is denoted by $r_i u_i(t)$, $v = r_i u_i(t)$.

The following constants are used for the total, the glycosomal, and the cytosolic volume:

$$\begin{aligned} c_{tot} &= V_{tot} &= \text{total cell volume} &= 5.7\ \mu l(mg)^{-1} \\ c_g &= V_g &= \text{volume glycosome} &= 0.2451\ \mu l(mg)^{-1} \\ c_c &= V_c &= \text{volume cytosol} &= 5.4549\ \mu l(mg)^{-1}. \end{aligned}$$

The other constants are denoted by $c_{i,j}$, is the j -th constant in rate equation r_i . The constants $k_{i,l}$ is the constant of specie S_l in rate equation r_i .

1. Glucose accross the cell- and the glycosomal membrane, by glucose carriers, [2, p.34, (2.11)],

$$r_1 = c_{1,1} \frac{c_{1,2}(x_2 - x_1)}{1 + x_2 c_{1,2} + x_1 c_{1,2} + c_{1,3} x_1 x_2 c_{1,2}^2}, \quad (\text{A.1})$$

with

$$\begin{aligned} r_1 &= v_{gltr}, \\ x_2 &= [Glc]_{ex} = S_1, \\ x_1 &= [Glc]_g = P_1, \\ c_{1,1} &= V^+ = 106.2\ \text{nmol}(\text{min})^{-1}(\text{mg cell protein})^{-1}, \\ c_{1,2} &= \frac{1}{K_{1,1}} = \frac{1}{K_{glc}} = \frac{1}{2}(\text{mM})^{-1}, \\ c_{1,3} &= \alpha = 0.75. \end{aligned}$$

2. The kinetics of HK is described by a Michaelis-Menten type equation for two substrates, [2, p.33, (2.9)],

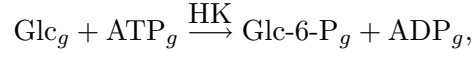

$$r_2 = c_{2,1} \frac{c_{2,2} x_6 x_1 c_{2,3}}{(1 + x_6 c_{2,2} + x_7 c_{2,4})(1 + x_1 c_{2,3})}, \quad (\text{A.2})$$

with

$$\begin{aligned} r_2 &= v_{\text{HK}}, \\ x_6 &= [\text{ATP}]_g = S_1, \\ x_1 &= [\text{Glc}]_g = S_2, \\ x_7 &= [\text{ADP}]_g = P_1, \\ x_3 &= [\text{Glc-6-P}]_g = P_2, \\ c_{2,1} &= V^+ = 625 \text{ nmol}(\text{min})^{-1}(\text{mg cell protein})^{-1}, \\ c_{2,2} &= \frac{1}{k_{2,6}} = \frac{1}{K_{\text{ATP}_g}} = \frac{1}{0.116} = 8.6207 \text{ (mM)}^{-1}, \\ c_{2,3} &= \frac{1}{k_{2,1}} = \frac{1}{K_{\text{Glu}c_g}} = \frac{1}{0.1} = 10 \text{ (mM)}^{-1}, \\ c_{2,4} &= \frac{1}{k_{2,7}} = \frac{1}{K_{\text{ADP}_g}} = \frac{1}{0.126} = 7.9365 \text{ (mM)}^{-1}. \end{aligned}$$

3. The reaction between Glc-6-P and Fru-6-P catalyzed by the enzyme PGI is assumed to be in equilibrium,



with

$$\begin{aligned} u_3 &= \text{PGI}, \\ x_3 &= [\text{Glc-6-P}]_g, \\ x_4 &= [\text{Fru-6-P}]_g. \end{aligned}$$

The equilibrium constant will be given in Subsection A.3.6.

4. The reaction equation catalyzed by PFK, it exhibits a cooperativity dependence on the concentration of Fru-6-P, [2, p.35, (2.12)],

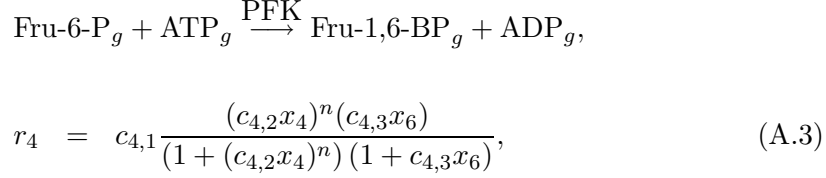

with

$$\begin{aligned} r_4 &= v_{\text{PFK}}, \\ x_4 &= [\text{Fru-6-P}]_g = S_1, \\ x_6 &= [\text{ATP}]_g = S_2, \\ x_5 &= [\text{Fru-1,6-BP}]_g = P_1, \\ x_7 &= [\text{ADP}]_g = P_2, \\ c_{4,1} &= V^+ = 780 \text{ nmol}(\text{min})^{-1}(\text{mg cell protein.})^{-1}, \\ c_{4,2} &= \frac{1}{k_{4,4}} = \frac{1}{K_{\text{m,Fru6P}_g}} = \frac{1}{0.82} = 1.2195 \text{ (mM)}^{-1}, \\ c_{4,3} &= \frac{1}{k_{4,6}} = \frac{1}{K_{\text{m,ATP}_g}} = \frac{1}{0.026} = 38.4615 \text{ (mM)}^{-1}, \\ n &= 1.2. \end{aligned}$$

5. The enzyme ALD works according to an ordered uni-bi mechanism, [2, p.35, (2.14)],



$$r_5 = c_{5,1} \frac{(c_{5,3}x_5 - c_{5,2}c_{5,4}c_{5,5}x_9x_{10})}{(1 + x_5(c_{5,3} + x_{10}c_{5,3}c_{5,6}) + x_{10}c_{5,5}(1 + x_9c_{5,4}) + x_9c_{5,4})},$$

with

$$\begin{aligned} r_5 &= v_{\text{ALD}}, \\ x_5 &= [\text{Fru-1,6-BP}]_g = S_1, \\ x_9 &= [\text{DHAP}]_g = P_1, \\ x_{10} &= [\text{GA-3-P}]_g = P_2, \\ c_{5,1} &= V^+ = 184.5 \text{ nmol}(\text{min})^{-1}(\text{mg cell protein.})^{-1}, \\ c_{5,2} &= \frac{V^-}{V^+} = 1.19, \\ c_{5,3} &= \frac{1}{k_{5,5}} = \frac{1}{K_{\text{m,Fru1,6BP}_g}} \\ &= \frac{1}{(9 \cdot 10^{-3} (1 + \frac{x_6}{0.68} + \frac{x_7}{1.51} + \frac{x_8}{3.65}))} \text{ (mM)}^{-1}, \\ c_{5,4} &= \frac{1}{k_{5,9}} = \frac{1}{K_{\text{m,DHAP}_g}} = \frac{1}{0.015} = 66.6667 \text{ (mM)}^{-1}, \\ c_{5,5} &= \frac{1}{k_{5,10m}} = \frac{1}{K_{\text{m,GA3P}_g}} = \frac{1}{0.067} = 14.9254 \text{ (mM)}^{-1}, \\ c_{5,6} &= \frac{1}{k_{5,10i}} = \frac{1}{K_{i,\text{GA3P}_g}} = \frac{1}{0.098} = 10.2041 \text{ (mM)}^{-1}. \end{aligned}$$

6. Nothing is known about the kinetics of DHAP catalyzed by TIM, so the reaction from DHAP to GA-3-P is assumed to be in equilibrium,

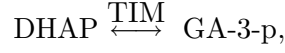

with

$$\begin{aligned} u_6 &= \text{TIM}, \\ x_9 &= [\text{DHAP}]_g, \\ x_{10} &= [\text{GA-3-P}]_g. \end{aligned}$$

7. The reaction catalyzed by GAPDH is described by the Michaelis-Menten equation for two non-competing product-substrate couples, [2, p.33, (2.10)],

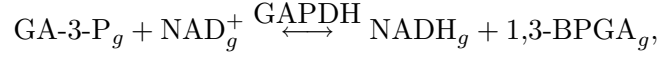

$$r_7 = c_{7,1} \frac{(x_{10}c_{7,3}x_{24}c_{7,4} - c_{7,2}x_{12}c_{7,5}x_{25}c_{7,6})}{(1 + x_{10}c_{7,3} + x_{12}c_{7,5})(1 + x_{24}c_{7,4} + x_{25}c_{7,6})}, \quad (\text{A.5})$$

with

$$\begin{aligned} r_7 &= v_{\text{GAPDH}}, \\ x_{10} &= [\text{GA-3-P}]_g = S_1, \\ x_{24} &= [\text{NAD}^+]_g = S_2, \\ x_{12} &= [1,3\text{-BPGA}]_g = P_1, \\ x_{25} &= [\text{NADH}]_g = P_2, \\ c_{7,1} &= V^+ = 1470 \text{ nmol}(\text{min})^{-1}(\text{mg cell protein})^{-1}, \\ c_{7,2} &= \frac{V^-}{V^+} = 0.67, \\ c_{7,3} &= \frac{1}{k_{7,10}} = \frac{1}{K_{\text{GA-3-P}_g}} = \frac{1}{0.15} = 6.6667 \text{ (mM)}^{-1}, \\ c_{7,4} &= \frac{1}{k_{7,24}} = \frac{1}{K_{\text{NAD}_g^+}} = \frac{1}{0.45} = 2.2222 \text{ (mM)}^{-1}, \\ c_{7,5} &= \frac{1}{k_{7,12}} = \frac{1}{K_{1,3\text{-BPGA}_g}} = \frac{1}{0.1} = 10 \text{ (mM)}^{-1}, \\ c_{7,6} &= \frac{1}{k_{7,25}} = \frac{1}{K_{\text{NADH}_g}} = \frac{1}{0.02} = 50 \text{ (mM)}^{-1}. \end{aligned}$$

8. The reaction catalyzed by PGK is described by the Michaelis-Menten equation for two non-competing product-substrate couples, [2, p.33, (2.10)],

$$1,3\text{-BPGA}_g + \text{ADP}_g \xrightleftharpoons{\text{PGK}} 3\text{-PGA}_g + \text{ATP}_g,$$

$$r_8 = c_{8,1} \frac{(x_{12}c_{8,3}x_7c_{8,4} - c_{8,2}x_{14}c_{8,5}x_6c_{8,6})}{(1 + x_{12}c_{8,3} + x_{14}c_{8,5})(1 + x_7c_{8,4} + x_6c_{8,6})}, \quad (\text{A.6})$$

with

$$\begin{aligned} r_8 &= v_{\text{PGK}}, \\ x_{12} &= [1,3\text{-BPGA}]_g = S_1, \\ x_7 &= [\text{ADP}]_g = S_2, \\ x_{14} &= [3\text{-PGA}]_g = P_1, \\ x_6 &= [\text{ATP}]_g = P_2, \\ c_{8,1} &= V^+ = 640 \text{ nmol}(\text{min})^{-1}(\text{mg cell protein.})^{-1}, \\ c_{8,2} &= \frac{V^-}{V^+} = 0.029, \\ c_{8,3} &= \frac{1}{k_{8,12}} = \frac{1}{K_{1,3\text{BPGA}_g}} = \frac{1}{0.05} = 20 \text{ (mM)}^{-1}, \\ c_{8,4} &= \frac{1}{k_{8,7}} = \frac{1}{K_{\text{ADP}_g}} = \frac{1}{0.1} = 10 \text{ (mM)}^{-1}, \\ c_{8,5} &= \frac{1}{k_{8,14}} = \frac{1}{K_{3\text{PGA}_g}} = \frac{1}{1.62} = 0.6173 \text{ (mM)}^{-1}, \\ c_{8,6} &= \frac{1}{k_{8,6}} = \frac{1}{K_{\text{ATP}_g}} = \frac{1}{0.29} = 3.4483 \text{ (mM)}^{-1}. \end{aligned}$$

9. Transport of 3-PGA across the glycosomal membrane, catalyzed by PGM is assumed to be in equilibrium,



with

$$\begin{aligned} u_9 &= \text{PGM}, \\ x_{14} &= [3\text{-PGA}]_g, \\ x_{32} &= [3\text{-PGA}]_c, \\ x_{34} &= [2\text{-PGA}]_c. \end{aligned}$$

10. The reaction of 2-PGA_c in PEP_c catalyzed by ENO is also assumed to be in equilibrium,

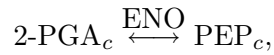

with

$$\begin{aligned} u_{10} &= \text{ENO}, \\ x_{34} &= [2\text{-PGA}]_c, \\ x_{15} &= [\text{PEP}]_c. \end{aligned}$$

11. The reaction equation catalyzed by PYK, consist of a cooperativity dependence of PEP, [2, p.35, (2.13)],

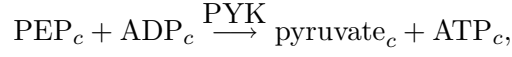

$$r_{11} = c_{11,1} \frac{(c_{11,2}x_{15})^n (c_{11,3}x_{18})}{(1 + (c_{11,2}x_{15})^n)(1 + c_{11,3}x_{18})}, \quad (\text{A.7})$$

with

$$\begin{aligned} r_{11} &= v_{\text{PYK}}, \\ x_{15} &= [\text{PEP}]_c = S_1, \\ x_{18} &= [\text{ADP}]_c = S_2, \\ x_{16} &= [\text{Pyruvate}]_c = P_1, \\ x_{17} &= [\text{ATP}]_c = P_2, \\ c_{11,1} &= V^+ = 2.6 \cdot 10^3 \text{ nmol}(\text{min})^{-1}(\text{mg cell protein.})^{-1}, \\ c_{11,2} &= \frac{1}{k_{11,15}} = \frac{1}{(0.34(1 + \frac{x_{17} + x_{18}}{0.57 + 0.64}))} (\text{mM})^{-1}, \\ c_{11,3} &= \frac{1}{k_{11,18}} = \frac{1}{0.114} = 8.7719 (\text{mM})^{-1}, \\ n &= 2.5. \end{aligned}$$

12. Pyruvate across the plasma membrane, by a pyruvate transporter, [2, p.33, (2.8)],

$$r_{12} = c_{12,1} \frac{c_{12,2}x_{16}}{1 + c_{12,2}x_{16}}, \quad (\text{A.8})$$

with

$$\begin{aligned} r_{12} &= v_{\text{Pytr}}, \\ x_{16} &= [\text{pyruvate}]_c = S_1, \\ c_{12,1} &= V^+ = 160 \text{ nmol}(\text{min})^{-1}(\text{mg cell protein.})^{-1}, \\ c_{12,2} &= \frac{1}{k_{15,16}} = \frac{1}{K_{\text{Pytr}_c}} = \frac{1}{1.96} = 0.5102 (\text{mM})^{-1}. \end{aligned}$$

13. The reaction kinetics of the reaction catalyzed by GDH is a reversible Michaelis-Menten kinetic for two non-competing product-substrate couples, [2, p.33, (2.10)],

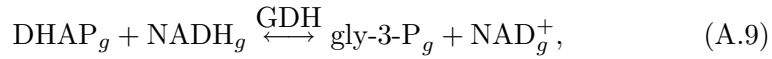

$$r_{13} = c_{13,1} \frac{x_9 c_{13,3} x_{25} c_{13,4} - c_{13,2} x_{11} c_{13,5} x_{24} c_{13,6}}{(1 + x_9 c_{13,3} + x_{11} c_{13,5})(1 + x_{25} c_{13,4} + x_{24} c_{13,6})},$$

with

$$\begin{aligned}
r_{13} &= v_{GDH}, \\
x_9 &= [\text{DHAP}]_g = S_1, \\
x_{25} &= [\text{NADH}]_g = S_2, \\
x_{11} &= [\text{Gly-3-P}]_g = P_1, \\
x_{24} &= [\text{NAD}^+]_g = P_2, \\
c_{13,1} &= V^+ = 425 \text{ nmol}(\text{min})^{-1}(\text{mg cell protein.})^{-1}, \\
c_{13,2} &= \frac{V^-}{V^+} = 0.07, \\
c_{13,3} &= \frac{1}{k_{8,9}} = \frac{1}{K_{\text{DHAP}_g}} = \frac{1}{0.85} = 1.1765 \text{ (mM)}^{-1}, \\
c_{13,4} &= \frac{1}{k_{8,25}} = \frac{1}{K_{\text{NADH}_g}} = \frac{1}{0.015} = 66.6667 \text{ (mM)}^{-1}, \\
c_{13,5} &= \frac{1}{k_{8,11}} = \frac{1}{K_{\text{Gly-3-P}_g}} = \frac{1}{6.4} = 0.1563 \text{ (mM)}^{-1}, \\
c_{13,6} &= \frac{1}{k_{8,24}} = \frac{1}{K_{\text{NAD}^+_g}} = \frac{1}{0.6} = 1.6667 \text{ (mM)}^{-1}.
\end{aligned}$$

14. The transport of Gly-3-P across the glycosomal membrane is assumed to be in equilibrium,

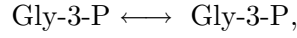

$$\begin{aligned}
u_{14} &= \text{Transporter of Gly-3-P}, \\
x_{11} &= [\text{Gly-3-P}]_g, \\
x_{21} &= [\text{Gly-3-P}]_c.
\end{aligned}$$

15. The reaction catalyzed by GPO is of irreversible Michaelis-Menten reaction kinetic [2, p.33, (2.8)],

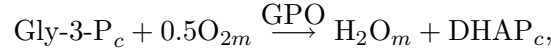

$$r_{15} = c_{15,1} \frac{c_{15,2}x_{21}}{1 + c_{15,2}x_{21}}, \quad (\text{A.10})$$

with

$$\begin{aligned}
r_{15} &= v_{GPO}, \\
x_{21} &= [\text{Gly-3-P}]_c, \\
x_{20} &= [\text{DHAP}]_c, \\
x_{22} &= [\text{H}_2\text{O}]_m, \\
x_{23} &= [\text{O}_2]_m, \\
c_{15,1} &= V^+ = 368 \text{ or } 0 \text{ nmol}(\text{min})^{-1}(\text{mg cell protein.})^{-1}, \\
c_{15,2} &= \frac{1}{k_{15,21}} = \frac{1}{K_{\text{Gly-3-P}_c}} = \frac{1}{1.7} = 0.5882 \text{ (mM)}^{-1}.
\end{aligned}$$

Under aerobic conditions V^+ is $368 \text{ nmol}(\text{min})^{-1}(\text{mg cell protein.})^{-1}$ and under anaerobic conditions $0 \text{ nmol}(\text{min})^{-1}(\text{mg cell protein.})^{-1}$.

16. Transport of DHAP across the glycosomal membrane, is assumed to be in equilibrium,

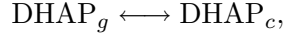

$$\begin{aligned} u_{16} &= \text{Transporter of DHAP,} \\ x_9 &= [\text{DHAP}]_g, \\ x_{20} &= [\text{DHAP}]_c. \end{aligned}$$

17. The reaction catalyzed by GK is of reversible Michaelis-Menten kinetic for two non-competing product-substrate couples, [2, p.33, (2.10)],



$$r_{17} = \frac{c_{17,1}(x_{11}c_{17,3}x_7c_{17,4} - c_{17,2}x_{13}c_{17,5}x_6c_{17,6})}{(1 + x_{11}c_{17,3} + x_{13}c_{17,5})(1 + x_7c_{17,4} + x_6c_{17,6})}, \quad (\text{A.11})$$

with

$$\begin{aligned} r_{17} &= v_{GK}, \\ x_{11} &= [\text{Gly-3-P}]_g = S_1, \\ x_7 &= [\text{ADP}]_g = S_2, \\ x_{13} &= [\text{Glycerol}]_g = P_1, \\ x_6 &= [\text{ATP}]_g = P_2, \\ c_{17,1} &= V^+ = 0 \text{ or } 200 \text{ nmol}(\text{min})^{-1}(\text{mg cell protein})^{-1}, \\ c_{17,2} &= \frac{V^-}{V^+} = 167, \\ c_{17,3} &= \frac{1}{k_{17,11}} = \frac{1}{K_{\text{Gly3P}_g}} = \frac{1}{5.1} = 0.1961 \text{ (mM)}^{-1}, \\ c_{17,4} &= \frac{1}{k_{17,7}} = \frac{1}{K_{\text{ADP}_g}} = \frac{1}{0.12} = 8.3333 \text{ (mM)}^{-1}, \\ c_{17,5} &= \frac{1}{k_{17,13}} = \frac{1}{K_{\text{Glyc}_g}} = \frac{1}{0.12} = 8.3333 \text{ (mM)}^{-1}, \\ c_{17,6} &= \frac{1}{k_{17,6}} = \frac{1}{K_{\text{ATP}_g}} = \frac{1}{0.19} = 5.2632 \text{ (mM)}^{-1}. \end{aligned}$$

Under aerobic conditions V^+ is 0 $\text{nmol}(\text{min})^{-1}(\text{mg cell protein})^{-1}$ and under anaerobic conditions 200 $\text{nmol}(\text{min})^{-1}(\text{mg cell protein})^{-1}$.

18. Transport of glycerol across the glycosomal membrane and the plasma membrane,



with

$$\begin{aligned} u_{18} &= \text{Transporter of glycerol,} \\ x_{13} &= [\text{glycerol}]_g, \\ x_{26} &= [\text{glycerol}]_{ex}, \\ x_{38} &= [\text{glycerol}]_c. \end{aligned}$$

19. The reaction of ATP in the glycosome into ADP in the glycosome, by ATP utilization [2, p.36, (2.15)],

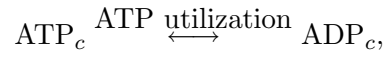

$$r_{19} = c_{19,1} \frac{x_{17}}{x_{18}}, \quad (\text{A.12})$$

with

$$\begin{aligned} x_{17} &= [\text{ATP}]_c = S_1, \\ x_{18} &= [\text{ADP}]_c = P_1, \\ c_{19,1} &= k = 50 \text{ nmol}(\text{min})^{-1}(\text{mg cell protein})^{-1}. \end{aligned}$$

20. The reaction of 2ADP into ATP and AMP in the glycosome is catalyzed by Glycosomal AK, [2],



with

$$\begin{aligned} x_6 &= [\text{ATP}]_g, \\ x_7 &= [\text{ADP}]_g, \\ x_8 &= [\text{AMP}]_g. \end{aligned}$$

21. The reaction of 2ADP into ATP and AMP in the cytosol is catalyzed by Cytosolic AK, [2],



with

$$\begin{aligned} x_{17} &= [\text{ATP}]_c, \\ x_{18} &= [\text{ADP}]_c, \\ x_{19} &= [\text{AMP}]_c. \end{aligned}$$

A.3.3 Differential equations

The following set of differential equations describes the time-dependent behaviour of glycolysis [2, p.37,38 (2.23-2.32)]. By definition: $\dot{x}_i(t) = \frac{dx_i}{dt}$, where $\dot{x}_i(t)$ is often denoted by \dot{x}_i .

1.

$$\begin{aligned} \frac{d[\text{Glc}]_{\text{in}}}{dt} &= \frac{v_{\text{glucose transport}} - v_{\text{HK}}}{V_{\text{tot}}} \\ \dot{x}_1 &= c_{\text{tot}1}(r_1 u_1 - r_2 u_2) = \\ &= 9.3158 \frac{(x_2 - x_1) u_1}{(1 + 0.5x_2 + 0.5x_1 + 0.1875x_1 x_2)} \\ &\quad - 9450.5106 \frac{x_6 x_1 u_2}{(1 + 8.6207x_6 + 7.9365x_7)(1 + 10x_1)} \\ x_1 &= [\text{Glc}]_g \\ r_1 u_1 &= v_{\text{glucose transport}} \\ r_2 u_2 &= v_{\text{HK}} \\ c_{\text{tot}1} &= \frac{1}{c_{\text{tot}}} = \frac{1}{V_{\text{tot}}} = \frac{1}{5.7} = 0.1754 \text{ } (\mu\text{l}/\text{mg})^{-1} \end{aligned} \tag{A.13}$$

2.

$$\begin{aligned} \frac{d[\text{hexose-P}]_g}{dt} &= \frac{v_{\text{Glucose transport}} - v_{\text{HK}}}{V_g} \\ \dot{x}_{30} &= c_{g1}(r_2 u_2 - r_4 u_4) = \\ &= 219825.8276 \frac{x_6 x_1 u_2}{(1 + 8.6207x_6 + 7.9365x_7)(1 + 10x_1)} \\ &\quad - 155310.6798 \frac{x_4^{1.2} x_6 u_4}{(1 + 1.2689x_4^{1.2})(1 + 38.4615x_6)} \\ x_{30} &= [\text{hexose-P}]_g \\ r_2 u_2 &= v_{\text{HK}} \\ r_4 u_4 &= v_{\text{PFK}} \\ c_{g1} &= \frac{1}{c_g} = \frac{1}{V_g} = \frac{1}{0.2451} = 4.0799 \text{ } (\mu\text{l}/\text{mg})^{-1} \end{aligned} \tag{A.14}$$

3.

$$\frac{d[\text{Fru-1,6-BP}]_g}{dt} = \frac{v_{\text{PFK}} - v_{\text{ALD}}}{V_g}$$

$$\begin{aligned} \dot{x}_5 &= c_{g1}(r_4u_4 - r_5u_5) = & (\text{A.15}) \\ &= 155310.6798 \frac{x_4^{1.2}x_6u_4}{(1 + 1.2689x_4^{1.2})(1 + 38.4615x_6)} \\ &\quad - \frac{752.7540(c_{53}x_5 - 1184.0796x_9x_{10})u_5}{1 + c_{53}x_5 + 14.9254x_{10} + 66.6667x_9 + 10.2041x_5x_{10}c_{53} + 995.0249x_9x_{10}} \\ c_{53} &= \frac{1}{0.009 + 0.0132x_6 + 0.0060x_7 + 0.0025x_8} \\ x_5 &= [\text{Fru-1,6-BP}]_g \\ r_4u_4 &= v_{\text{PFK}} \\ r_5u_5 &= v_{\text{ALD}} \\ c_{g1} &= 4.0799 (\mu\text{l}/\text{mg})^{-1} \end{aligned}$$

4.

$$\frac{d[\text{Triose-P}]}{dt} = \frac{2v_{\text{ALD}} - v_{\text{GAPDH}} - v_{\text{GDH}} + v_{\text{GPO}}}{V_{\text{tot}}}$$

$$\begin{aligned} \dot{x}_{31} &= c_{tot1}(2r_5u_5 - r_7u_7 - r_{13}u_{13} + r_{15}u_{15}) = & (\text{A.16}) \\ &= \frac{64.7368(c_{53}x_5 - 1184.0796x_9x_{10})u_5}{1 + c_{53}x_5 + 14.9254x_{10} + 66.6667x_9 + 10.2041x_5x_{10}c_{53} + 995.0249x_9x_{10}} \\ &\quad - 257.8947 \frac{(14.8148x_{10}x_{24} - 335.00x_{12}x_{25})u_7}{(1 + 6.6667x_{10} + 10x_{12})(1 + 2.2222x_{24} + 50x_{25})} \\ &\quad - 74.5614 \frac{(78.4314x_9x_{25} - 0.0182x_{11}x_{24})u_{13}}{(1 + 1.1765x_9 + 0.1563x_{11})(1 + 66.6667x_{25} + 1.6667x_{24})} \\ &\quad + 37.9773 \frac{x_{21}u_{15}}{1 + 0.5882x_{21}} \\ x_{31} &= [\text{triose-P}] \\ r_5u_5 &= v_{\text{ALD}} \\ r_7u_7 &= v_{\text{GAPDH}} \\ r_{13}u_{13} &= v_{\text{GDH}} \\ r_{15}u_{15} &= v_{\text{GPO}} \\ c_{tot1} &= 0.1754 (\mu\text{l}/\text{mg})^{-1} \end{aligned}$$

5.

$$\frac{d[1,3\text{-BPGA}]_g}{dt} = \frac{v_{\text{GAPDH}} - v_{\text{PGK}}}{V_g}$$

$$\begin{aligned} \dot{x}_{12} &= c_{g1}(r_7 u_7 - r_8 u_8) = & (\text{A.17}) \\ &= 5997.5520 \frac{(14.8148 x_{10} x_{24} - 335.00 x_{12} x_{25}) u_7}{(1 + 6.6667 x_{10} + 10 x_{12})(1 + 2.2222 x_{24} + 50 x_{25})} \\ &\quad - 2611.1791 \frac{(200 x_{12} x_7 - 0.0617 x_{14} x_6) u_8}{(1 + 20 x_{12} + 0.6173 x_{14})(1 + 10 x_7 + 3.4483 x_6)} \\ x_{12} &= [1,3\text{-BPGA}]_g \\ r_7 u_7 &= v_{\text{GAPDH}} \\ r_8 u_8 &= v_{\text{PGK}} \\ c_{g1} &= 4.0799 (\mu\text{l}/\text{mg})^{-1} \end{aligned}$$

6.

$$\frac{d[\text{N}]}{dt} = \frac{v_{\text{PGK}} - v_{\text{PYK}}}{V_{\text{tot}}}$$

$$\begin{aligned} \dot{x}_{35} &= c_{\text{tot}1}(r_8 u_8 - r_{11} u_{11}) & (\text{A.18}) \\ &= 112.2807 \frac{(200 x_{12} x_7 - 0.0617 x_{14} x_6) u_8}{(1 + 20 x_{12} + 0.6173 x_{14})(1 + 10 x_7 + 3.4483 x_6)} \\ &\quad - 4001.2311 \frac{\left(\frac{x_{15}}{0.34 + 0.5965 x_{17} + 0.5313 x_{18}}\right)^{2.5} x_{18} u_{11}}{\left(1 + \left(\frac{x_{15}}{0.34 + 0.5965 x_{17} + 0.5313 x_{18}}\right)^{2.5}\right) (1 + 8.7719 x_{18})} \\ x_{35} &= [\text{N}] \\ r_8 u_8 &= v_{\text{PGK}} \\ r_{11} u_{11} &= v_{\text{PYK}} \\ c_{\text{tot}1} &= 0.1754 (\mu\text{l}/\text{mg})^{-1} \end{aligned}$$

7.

$$\frac{d[\text{Pyr}]_c}{dt} = \frac{v_{\text{PYK}} - v_{\text{Pyruvate transport}}}{V_c}$$

$$\dot{x}_{16} = c_{c1}(r_{11}u_{11} - r_{12}u_{12}) = \tag{A.19}$$

$$= 4181.0148 \frac{\left(\frac{x_{15}}{0.34+0.5965x_{17}+0.5313x_{18}}\right)^{2.5} x_{18}u_{11}}{\left(1 + \left(\frac{x_{15}}{0.34+0.5965x_{17}+0.5313x_{18}}\right)^{2.5}\right) (1 + 8.7719x_{18})} - 14.9650 \frac{x_{16}u_{12}}{1 + 0.5102x_{16}}$$

$$x_{16} = [\text{Pyruvate}]_c$$

$$r_{11}u_{11} = v_{\text{PYK}}$$

$$r_{12}u_{12} = v_{\text{Pyruvate transport}}$$

$$c_{c1} = \frac{1}{c_{c1}} = \frac{1}{V_{c1}} = \frac{1}{5.4549} = 0.1833 \text{ } (\mu\text{l}/\text{mg})^{-1}$$

8.

$$\frac{d[\text{NADH}]_g}{dt} = \frac{v_{\text{GAPDH}} - v_{\text{GDH}}}{V_g}$$

$$\dot{x}_{25} = c_{g1}(r_7u_7 - r_{13}u_{13}) = \tag{A.20}$$

$$= 5997.5520 \frac{(14.8148x_{10}x_{24} - 335.00x_{12}x_{25})u_7}{(1 + 6.6667x_{10} + 10x_{12})(1 + 2.2222x_{24} + 50x_{25})} - 1733.9861 \frac{(78.4314x_9x_{25} - 0.0182x_{11}x_{24})u_{13}}{(1 + 1.1765x_9 + 0.1563x_{11})(1 + 66.6667x_{25} + 1.6667x_{24})}$$

$$x_{25} = [\text{NADH}]_g$$

$$r_7u_7 = v_{\text{GAPDH}}$$

$$r_{13}u_{13} = v_{\text{GDH}}$$

$$c_{g1} = 4.0799 \text{ } (\mu\text{l}/\text{mg})^{-1}$$

9.

$$\frac{dP_g}{dt} = \frac{-v_{HK} - v_{PFK} + v_{PGK} + v_{GK}}{V_g}$$

$$\begin{aligned} \dot{x}_{36} &= c_{g1}(-r_2 u_2 - r_4 u_4 + u_8 r_8 + r_{17} u_{17}) = & (A.21) \\ &= -219825.8276 \frac{x_6 x_1 u_2}{(1 + 8.621 x_6 + 7.9365 x_7)(1 + 10 x_1)} \\ &\quad -155310.6798 \frac{x_4^{1.2} x_6 u_4}{(1 + 1.2689 x_4^{1.2})(1 + 38.4615 x_6)} \\ &\quad +2611.1791 \frac{(200 x_{12} x_7 - 0.0617 x_{14} x_6) u_8}{(1 + 20 x_{12} + 0.6173 x_{14})(1 + 10 x_7 + 3.4483 x_6)} \\ &\quad +815.9935 \frac{(1.6340 x_{11} x_7 - 7324.5614 x_{13} x_6) u_{17}}{(1 + 0.1961 x_{11} + 8.3333 x_7)(1 + 8.3333 x_{13} + 5.2632 x_6)} \end{aligned}$$

$$x_{36} = [P]_g$$

$$r_2 u_2 = v_{HK}$$

$$r_4 u_4 = v_{PFK}$$

$$r_8 u_8 = v_{PGK}$$

$$r_{17} u_{17} = v_{GK}$$

$$c_{g1} = 4.0799 (\mu l/mg)^{-1}$$

10.

$$\frac{dP_c}{dt} = \frac{v_{PYK} - v_{ATP \text{ utilization}}}{V_c}$$

$$\begin{aligned} \dot{x}_{37} &= c_{c1}(r_{11} u_{11} - r_{19} u_{19}) = & (A.22) \\ &= 4181.0148 \frac{\left(\frac{x_{15}}{0.34+0.5965x_{17}+0.5313x_{18}}\right)^{2.5} x_{18} u_{11}}{\left(1 + \left(\frac{x_{15}}{0.34+0.5965x_{17}+0.5313x_{18}}\right)^{2.5}\right) (1 + 8.7719 x_{18})} \\ &\quad -9.1661 \frac{x_{17} u_{19}}{x_{18}} \end{aligned}$$

$$x_{37} = [P]_c$$

$$r_{11} u_{11} = v_{PYK}$$

$$r_{19} u_{19} = v_{ATP \text{ utilization}}$$

$$c_{c1} = 0.1833 (\mu l/mg)^{-1}$$

A.3.4 Moiety-conservation relations

For the model of glycolysis in *Trypanosoma brucei* four moiety relations can be obtained, with the help of the reaction scheme [2, p.30, (2.1-2.4)]. The following list is a list of moiety equations:

1.

$$\begin{aligned}
 [\text{ATP}]_g + [\text{ADP}]_g + [\text{AMP}]_g &= c_1 \\
 x_6 + x_7 + x_8 &= c_1 \\
 x_6 &= [\text{ATP}]_g \\
 x_7 &= [\text{ADP}]_g \\
 x_8 &= [\text{AMP}]_g \\
 c_1 &= 3.9 \text{ mM}
 \end{aligned} \tag{A.23}$$

2.

$$\begin{aligned}
 [\text{ATP}]_c + [\text{ADP}]_c + [\text{AMP}]_c &= c_2 \\
 x_{17} + x_{18} + x_{19} &= c_2 \\
 x_{17} &= [\text{ATP}]_c \\
 x_{18} &= [\text{ADP}]_c \\
 x_{19} &= [\text{AMP}]_c \\
 c_2 &= 3.9 \text{ mM}
 \end{aligned} \tag{A.24}$$

3.

$$\begin{aligned}
 [\text{NADH}]_g + [\text{NAD}]_g^+ &= c_3 \\
 x_{25} + x_{24} &= c_3 \\
 x_{25} &= [\text{NADH}]_g \\
 x_{24} &= [\text{NAD}]_g^+ \\
 c_3 &= 4 \text{ mM}
 \end{aligned} \tag{A.25}$$

4.

$$\begin{aligned}
 c_4 V_g &= [\text{Gly-3-P}]_g V_g + [\text{Gly-3-P}]_c V_c + [\text{DHAP}]_g V_g + \\
 &\quad + [\text{DHAP}]_c V_c + [\text{Glc-6-P}]_g V_g + [\text{Fru-6-P}]_g V_g + \\
 &\quad + 2 [\text{Fru-1,6-BP}]_g V_g + [\text{GA-3-P}]_g V_g + [1,3\text{-BPGA}]_g V_g + \\
 &\quad + 2 [\text{ATP}]_g V_g + [\text{ADP}]_g V_g \\
 c_4 c_g &= x_{11} c_g + x_{21} c_c + x_9 c_g + x_{20} c_c + x_3 c_g + x_4 c_g + \\
 &\quad + 2x_5 c_g + x_{10} c_g + x_{12} c_g + 2x_6 c_g + x_7 c_g
 \end{aligned}$$

$$\begin{aligned}
x_{11} &= [\text{Gly-3-P}]_g \\
x_{21} &= [\text{Gly-3-P}]_c \\
x_9 &= [\text{DHAP}]_g \\
x_{20} &= [\text{DHAP}]_c \\
x_3 &= [\text{Glc-6-P}]_g \\
x_4 &= [\text{Fru-6-P}]_g \\
x_5 &= [\text{Fru-1,6-BP}]_g \\
x_{10} &= [\text{GA-3-P}]_g \\
x_{12} &= [1,3\text{-BPGA}]_g \\
x_6 &= [\text{ATP}]_g \\
x_7 &= [\text{ADP}]_g \\
c_g &= V_g = 0.2451 \\
c_c &= V_c = 5.4549 \\
c_4 &= 120 \text{ mM}
\end{aligned}$$

Since Gly-3-P and DHAP were assumed to be in equilibrium across the glycosomal membrane, this equation is simplified to, [2, p.30, (2.5)]:

$$\begin{aligned}
c_4 &= ([\text{Gly-3-P}] + [\text{DHAP}]) \left(1 + \frac{V_c}{V_g}\right) + [\text{Glc-6-P}]_g \\
&\quad + [\text{Fru-6-P}]_g + 2 [\text{Fru-1,6-BP}]_g + [\text{GA-3-P}]_g \\
&\quad + [1,3\text{-BPGA}]_g + 2 [\text{ATP}]_g + [\text{ADP}]_g \\
c_4 &= (x_{28} + x_{29})(1 + c_q) + x_3 + x_4 \\
&\quad + 2x_5 + x_{10} + x_{12} + 2x_6 + x_7 \\
x_{28} &= [\text{Gly-3-P}] \\
x_{29} &= [\text{DHAP}] \\
c_q &= \frac{c_c}{c_g} = \frac{V_c}{V_g} = 22.2558 \\
c_4 &= 120 \text{ mM}
\end{aligned} \tag{A.26}$$

Hereby the following equalities hold, [2, p.30, (2.6), (2.7), and (2.19)]:

$$\begin{aligned}
[\text{Gly-3-P}] &\equiv [\text{Gly-3-P}]_g = [\text{Gly-3-P}]_c \\
x_{28} &\equiv x_{11} = x_{21} \\
x_{28} &= [\text{Gly-3-P}] \\
x_{11} &= [\text{Gly-3-P}]_g \\
x_{21} &= [\text{Gly-3-P}]_c,
\end{aligned} \tag{A.27}$$

$$\begin{aligned}
[\text{DHAP}] &\equiv [\text{DHAP}]_g = [\text{DHAP}]_c \\
x_{29} &\equiv x_9 = x_{20} \\
x_{29} &= [\text{DHAP}] \\
x_9 &= [\text{DHAP}]_g \\
x_{20} &= [\text{DHAP}]_c,
\end{aligned} \tag{A.28}$$

and

$$\begin{aligned}
[\text{3-PGA}] &\equiv [\text{3-PGA}]_g = [\text{3-PGA}]_c \\
x_{33} &\equiv x_{14} = x_{32} \\
x_{33} &= [\text{3-PGA}] \\
x_{14} &= [\text{3-PGA}]_g \\
x_{32} &= [\text{3-PGA}]_c.
\end{aligned} \tag{A.29}$$

A.3.5 Pools

If a reaction is assumed to be in equilibrium, its substrates and its products will be treated as a single metabolite pool. The model of glycolysis in *Trypanosoma brucei* consists of in total 5 metabolite pools, [2, p.37, (2.16-2.20)]. The following equations are the metabolite pools:

1. The sum of hexose phosphates in the glycosome is:

$$\begin{aligned}
[\text{hexose-P}]_g &\equiv [\text{Glc-6-P}]_g + [\text{Fru-6-P}]_g \\
x_{30} &\equiv x_3 + x_4 \\
x_{30} &= [\text{hexose-P}]_g \\
x_3 &= [\text{Glc-6-P}]_g \\
x_4 &= [\text{Fru-6-P}]_g
\end{aligned} \tag{A.30}$$

2. The sum of triose phosphate is:

$$\begin{aligned}
[\text{triose-P}] &\equiv \frac{[\text{DHAP}]_c V_c + [\text{DHAP}]_g V_g + [\text{GA-3-P}]_g V_g}{V_{tot}} \quad [2,p.37,(2.16)] \\
&= \frac{[\text{DHAP}](V_c + V_g) + [\text{GA-3-P}]_g V_g}{(V_g + V_c)} = \\
&= \frac{[\text{DHAP}] \left(1 + \frac{V_c}{V_g}\right) + [\text{GA-3-P}]_g}{\left(1 + \frac{V_c}{V_g}\right)} \\
x_{31} &\equiv \frac{x_{29}(1 + c_q) + x_{10}}{(1 + c_q)} \quad (\text{A.31}) \\
x_{31} &= [\text{Triose-P}] \\
x_{20} &= [\text{DHAP}]_c \\
x_9 &= [\text{DHAP}]_g \\
x_{10} &= [\text{GA-3-P}]_g \\
x_{29} &= [\text{DHAP}] \\
c_q &= \frac{c_c}{c_g} = \frac{V_c}{V_g} = 22.2558
\end{aligned}$$

3. A pool [N] is defined by:

$$\begin{aligned}
[\text{N}] &\equiv \frac{[\text{3-PGA}](V_g + V_c) + [\text{2-PGA}]_c V_c + [\text{PEP}]_c V_c}{V_{tot}} = \\
&= \frac{[\text{3-PGA}] \left(1 + \frac{V_c}{V_g}\right) + [\text{2-PGA}]_c \frac{V_c}{V_g} + [\text{PEP}]_c \frac{V_c}{V_g}}{\left(1 + \frac{V_c}{V_g}\right)},
\end{aligned}$$

here [2, p.37, (2.19)] is used.

$$\begin{aligned}
x_{35} &\equiv \frac{x_{33}(1 + c_q) + x_{34}c_q + x_{15}c_q}{(1 + c_q)} \quad (\text{A.32}) \\
x_{35} &= [\text{N}] \\
x_{33} &= [\text{3-PGA}] \\
x_{34} &= [\text{2-PGA}]_c \\
x_{15} &= [\text{PEP}]_c \\
c_q &= 22.2558
\end{aligned}$$

4. Finally two variables P_g and P_c , denoting the sums of high energy phosphates in the glycosome and the cytosol, respectively, were defined:

$$\begin{aligned}
[P]_g &\equiv 2[\text{ATP}]_g + [\text{ADP}]_g \\
x_{36} &\equiv 2x_6 + x_7 \\
x_{36} &= [P]_g \\
x_6 &= [\text{ATP}]_g \\
x_7 &= [\text{ADP}]_g
\end{aligned} \tag{A.33}$$

- 5.

$$\begin{aligned}
[P]_c &\equiv 2[\text{ATP}]_c + [\text{ADP}]_c \\
x_{37} &\equiv 2x_{17} + x_{18} \\
x_{37} &= [P]_c \\
x_{17} &= [\text{ATP}]_c \\
x_{18} &= [\text{ADP}]_c
\end{aligned} \tag{A.34}$$

A.3.6 Fast dynamics

The transport of metabolites across the glycosomal membrane was assumed to be driven only by concentration gradients of these metabolites and consequently the corresponding equilibrium constants were 1. The individual metabolite concentrations were calculated from the equilibrium pools as follows:

1. [2, p.39, (2.33)]

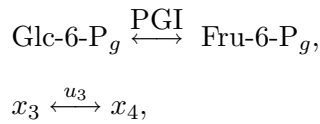

with equilibrium equation,

$$\begin{aligned}
\frac{[\text{Fru-6-P}]_g}{[\text{Glc-6-P}]_g} &= K_{\text{eq,PGI}}, \\
\frac{x_4}{x_3} &= c_{\text{eq},3}, \\
x_4 &= [\text{Fru-6-P}]_g, \\
x_3 &= [\text{Glc-6-P}]_g, \\
c_{\text{eq},3} &= K_{\text{eq,PGI}} = 0.29.
\end{aligned} \tag{A.35}$$

2. [2, p.39, (2.35)]



with equilibrium equation,

$$\begin{aligned} \frac{[\text{GA-3-P}]_g}{[\text{DHAP}]_g} &= K_{\text{eq,TIM}}, \\ \frac{x_{10}}{x_9} &= c_{\text{eq},6}, \\ x_{10} &= [\text{GA-3-P}]_g, \\ x_9 &= [\text{DHAP}]_g, \\ c_{\text{eq},6} &= K_{\text{eq,TIM}} = 0.045. \end{aligned} \tag{A.36}$$

3. [2, p.39, (2.37) and (2,38)]



The equilibrium equations of PGM and ENO are:

$$\frac{[2\text{-PGA}]_c}{[3\text{-PGA}]_c} = K_{\text{eq,PGM}},$$

and

$$\frac{[\text{PEP}]_c}{[2\text{-PGA}]_c} = K_{\text{eq,ENO}}.$$

This leads to

$$\frac{x_{34}}{x_{32}} = c_{\text{eq},9}, \tag{A.37}$$

and

$$\frac{x_{15}}{x_{34}} = c_{\text{eq},10}, \tag{A.38}$$

with

$$\begin{aligned} x_{34} &= [2\text{-PGA}]_c, \\ x_{32} &= [3\text{-PGA}]_c, \\ x_{15} &= [\text{PEP}]_c, \\ c_{\text{eq},9} &= K_{\text{eq,PGM}} = 0.187, \\ c_{\text{eq},10} &= K_{\text{eq,ENO}} = 6.7. \end{aligned}$$

4. [2, p.40, (2.40)]



The equilibrium equation for 2ADP, ATP, and AMP in the glycosome is

$$\begin{aligned} \frac{[\text{AMP}]_g[\text{ATP}]_g}{[\text{ADP}]_g^2} &= K_{\text{eq,AK}}, \\ \frac{x_8 x_6}{(x_7)^2} &= c_{\text{eq},20}, \\ x_6 &= [\text{ATP}]_g, \\ x_7 &= [\text{ADP}]_g, \\ x_8 &= [\text{AMP}]_g, \\ c_{\text{eq},20} &= K_{\text{eq,AK}} = 0.442. \end{aligned} \tag{A.39}$$

5.



The equilibrium equation for 2ADP, ATP, and AMP in the cytosol is

$$\begin{aligned} \frac{[\text{AMP}]_c[\text{ATP}]_c}{[\text{ADP}]_c^2} &= c_{\text{eq,AK}}, \\ \frac{x_{19} x_{17}}{(x_{18})^2} &= c_{\text{eq},20}, \\ x_{17} &= [\text{ATP}]_c, \\ x_{18} &= [\text{ADP}]_c, \\ x_{19} &= [\text{AMP}]_c, \\ c_{\text{eq},20} &= K_{\text{eq,AK}} = 0.442. \end{aligned} \tag{A.40}$$

A.3.7 Algebraic equations

With the help of the pools and the fast dynamics algebraic equations can be found, describing relations between some of the state variables.

It follows from [2, p.37, (2.16)] and [2, p.39,(2.33)] that

$$\begin{aligned}
\frac{[\text{hexose-P}]_g}{1 + K_{\text{eq,PGI}}} &\stackrel{[2,(2.16)]}{=} \frac{[\text{Glc-6-P}]_g + [\text{Fru-6-P}]_g}{1 + K_{\text{eq,PGI}}} = \\
&\stackrel{[2,(2.33)]}{=} \frac{[\text{Glc-6-P}]_g + [\text{Fru-6-P}]_g}{1 + \frac{[\text{Fru-6-P}]_g}{[\text{Glc-6-P}]_g}} = \\
&= \frac{[\text{Glc-6-P}]_g^2 + [\text{Glc-6-P}]_g \cdot [\text{Fru-6-P}]_g}{[\text{Glc-6-P}]_g + [\text{Fru-6-P}]_g} = \\
&= [\text{Glc-6-P}]_g,
\end{aligned}$$

this gives

$$\frac{x_{30}}{1 + c_{\text{eq},3}} = x_3. \tag{A.41}$$

It follows from [2, p.37, (2.17)] and [2, p.39, (2.35)] that

$$\begin{aligned}
\frac{[\text{triose-P}] \left(1 + \frac{V_c}{V_g}\right)}{1 + \frac{V_c}{V_g} + K_{\text{eq,TIM}}} &\stackrel{[2,(2.17)]}{=} \frac{[\text{DHAP}] \left(1 + \frac{V_c}{V_g}\right) + [\text{GA-3-P}]_g}{1 + \frac{V_c}{V_g} + K_{\text{eq,TIM}}} = \\
&\stackrel{[2,(2.35)]}{=} \frac{[\text{DHAP}] \left(1 + \frac{V_c}{V_g}\right) + [\text{GA-3-P}]_g}{1 + \frac{V_c}{V_g} + \frac{[\text{GA-3-P}]_g}{[\text{DHAP}]}} = \\
&= \frac{[\text{DHAP}]^2 \left(1 + \frac{V_c}{V_g}\right) + [\text{DHAP}] \cdot [\text{GA-3-P}]_g}{\left(1 + \frac{V_c}{V_g}\right) [\text{DHAP}] + [\text{GA-3-P}]_g} = \\
&= [\text{DHAP}],
\end{aligned}$$

this gives [2, p.39, (2.36)]

$$x_{29} = \frac{x_{31} (1 + c_q)}{1 + c_q + c_{\text{eq},6}}, \tag{A.42}$$

with

$$\begin{aligned}
x_{31} &= [\text{triose-P}], \\
x_{29} &= [\text{DHAP}], \\
c_q &= 22.2558, \\
c_{\text{eq},6} &= 0.045.
\end{aligned}$$

With [2, p.37, (2.19)], [2, p.37, (2.20)], [2, p.39, (2.37)], and [2, p.39, (2.38)] it follows that [2, p.40, (2.39)] holds:

$$\begin{aligned}
& \frac{[N] \left(1 + \frac{V_c}{V_g}\right)}{\left(1 + (1 + K_{\text{eq,PGM}} + K_{\text{eq,PGM}} \cdot K_{\text{eq,ENO}}) \frac{V_c}{V_g}\right)} = \\
& \stackrel{[2,(2.37)], [2,(2.38)]}{=} \frac{[N] \left(1 + \frac{V_c}{V_g}\right)}{1 + \left(1 + \frac{[2\text{-PGA}]_c}{[3\text{-PGA}]_c} + \frac{[\text{PEP}]_c}{[3\text{-PGA}]_c}\right) \frac{V_c}{V_g}} = \\
& \stackrel{[2,(2.19)]}{=} \frac{[N] \left(1 + \frac{V_c}{V_g}\right)}{1 + \left(1 + \frac{[2\text{-PGA}]_c}{[3\text{-PGA}]_c} + \frac{[\text{PEP}]_c}{[3\text{-PGA}]_c}\right) \frac{V_c}{V_g}} = \\
& \stackrel{[2,(2.20)]}{=} \frac{\frac{([3\text{-PGA}] \left(1 + \frac{V_c}{V_g}\right) + [2\text{-PGA}]_c \frac{V_c}{V_g} + [\text{PEP}]_c \frac{V_c}{V_g}) \left(1 + \frac{V_c}{V_g}\right)}{\left(1 + \frac{V_c}{V_g}\right)}}{\frac{\left(1 + \frac{V_c}{V_g} + \frac{2\text{-PGA}_c V_c}{3\text{-PGA} V_g} + \frac{\text{PEP}_c V_c}{3\text{-PGA} V_g}\right)}{\left(1 + \frac{V_c}{V_g}\right)}} = \\
& = \frac{[3\text{-PGA}] \left([3\text{-PGA}] \left(1 + \frac{V_c}{V_g}\right) + [2\text{-PGA}]_c \frac{V_c}{V_g} + [\text{PEP}]_c \frac{V_c}{V_g}\right)}{\left([3\text{-PGA}] \left(1 + \frac{V_c}{V_g}\right) + [2\text{-PGA}]_c \frac{V_c}{V_g} + [\text{PEP}]_c \frac{V_c}{V_g}\right)} = \\
& = [3\text{-PGA}].
\end{aligned}$$

So for x_{33} the following is obtained:

$$\begin{aligned}
x_{33} &= \frac{x_{35} (1 + c_q)}{(1 + (1 + c_{eq,9} + c_{eq,9} c_{eq,10}) c_q)}, & (\text{A.43}) \\
x_{33} &= [3\text{-PGA}], \\
x_{35} &= [N], \\
c_q &= 22.2558.
\end{aligned}$$

A.3.8 Reduction of state variables

In the model of glycolysis of *Trypanosoma brucei* a system of 10 differential equations with 37 unknowns is considered. With the help of the algebraic equations, pools and fast dynamics, unknowns can be expressed in the 10 state variables, for which we have a differential equation in the system of differential equations, namely $\{x_1, x_{30}, x_5, x_{31}, x_{12}, x_{35}, x_{16}, x_{25}, x_{36}, x_{37}\}$.

First the external concentration x_2 is assumed to be 5 mM. The state x_3 is depending of x_{30} with the help of algebraic equation A.41 and x_4 can be expressed by this expression and the equilibrium equation, A.35, between

x_3 and x_4 . These states are, respectively,

$$x_3 = \frac{x_{30}}{(1 + 0.29)} = 0.7752x_{30} \text{ and } x_4 = \frac{0.29x_{30}}{(1 + 0.29)} = 0.2248x_{30}.$$

To see the relation between x_6 and x_{36} ,

$$x_6 = 2.5391 + 0.5000x_{36} - 0.6510\sqrt{(3.9 + 0.768x_{36})^2 - 1.3578x_{36}^2},$$

A.23, A.33 and A.39 are used. starting with A.39 the following is obtained:

$$\begin{aligned} \frac{x_8x_6}{(x_7)^2} &\stackrel{A.23}{\Rightarrow} (c_1 - x_6 - x_7)x_6 = c_{eq,20}x_7^2 \\ &\stackrel{A.33}{\Rightarrow} (c_1 - x_6 - x_{36} + 2x_6)x_6 = c_{eq,20}(x_{36} - 2x_6)^2 \\ &\Rightarrow c_1x_6 + x_6^2 - x_{36}x_6 = c_{eq,20}x_{36}^2 + 4c_{eq,20}x_6^2 - 4c_{eq,20}x_6x_{36} \\ &\Rightarrow (1 - 4c_{eq,20})x_6^2 + (c_1 - x_{36} + 4c_{eq,20}x_{36})x_6 - c_{eq,20}x_{36}^2 = 0. \end{aligned}$$

With the help of the ABC-formula the relevant solution of this is [2, p.40, (2.41)]

$$x_6 = \frac{-b_g + \sqrt{b_g^2 - 4a_gz_g}}{2a_g},$$

in which

$$\begin{aligned} a_g &= 1 - 4c_{eq,20}, \\ b_g &= c_1 - x_{36}(1 - 4c_{eq,20}), \\ z_g &= -c_{eq,20}(x_{36})^2, \\ x_{36} &= [P]_g, \\ c_{eq,20} &= 0.442, \\ c_1 &= 3.9. \end{aligned} \tag{A.44}$$

Now x_7 can be found with equation A.33, from x_6 and x_{36} , and by this also depends of x_{36} . So the expression for x_7 is the following:

$$x_7 = -5.0781 + 1.3021\sqrt{(3.9 + 0.768x_{36})^2 - 1.3578x_{36}^2}.$$

The expression for x_8 can be found with A.23 and the expressions for x_6 and x_7 ,

$$x_8 = 6.4391 - 0.5000x_{36} - 0.6510\sqrt{(3.9 + 0.768x_{36})^2 - 1.3578x_{36}^2}.$$

So x_8 also depend of x_{36} . The expression for the states x_9 can be found with A.42, A.36 and A.28, starting with A.42,

$$\begin{aligned}
x_{31} &\stackrel{\text{A.42}}{=} \frac{x_{29}23.2558 + x_{10}}{23.2558} \\
&\stackrel{\text{(A.28)}}{=} \frac{x_9 23.2558 + x_{10}}{23.2558} \\
&\stackrel{\text{(A.36)}}{=} \frac{x_9 23.2558 + 0.045x_9}{23.2558} \\
&\Rightarrow 0.9981x_{31} = x_9.
\end{aligned}$$

By this expression for x_9 and by A.36, $x_{10} = 0.0449x_{31}$. With relations A.26, A.27, and A.28 and by using x_9 and the relation of x_{29} , x_{11} can be found,

$$x_{11} = 5.1600 - 1.0000x_{31} - 0.0430x_{30} - 0.0860x_5 - 0.0430x_{12} - 0.0430x_{36}.$$

Under O_2 rich conditions, glycerol in the glycosome is assumed to be zero, $x_{13} = 0$. Now $x_{14} = 0.4205x_{35}$, this can be seen by A.29 and A.43. The state x_{15} is found by A.37, A.38 and A.43,

$$x_{15} = 0.5269x_{35}.$$

The expression for x_{17} can be found with A.24, A.34 and A.40 at same way as x_6 . So x_{17} depends on x_{37} . The relevant solution for x_{17} is

$$x_{17} = \frac{-b_c + \sqrt{b_c^2 - 4a_c z_c}}{2a_c},$$

with

$$\begin{aligned}
a_c &= 1 - 4c_{eq,20}, \\
b_c &= c_2 - x_{37}(1 - 4c_{eq,20}), \\
z_c &= -c_{eq,20}(x_{37})^2, \\
x_{37} &= [P]_c, \\
c_2 &= 3.9.
\end{aligned}$$

Now x_{18} and x_{19} can be expressed with the help of x_{17} . With A.34 and x_{17}

$$x_{18} = -5.0781 + 1.302\sqrt{(3.9 + 0.768x_{37})^2 - 1.3578x_{37}^2},$$

then with A.24, x_{17} and x_{18}

$$x_{19} = 6.4391 - 0.5000x_{37} - 0.6510\sqrt{(3.9 + 0.768x_{37})^2 - 1.358x_{37}^2}.$$

The state x_{20} can be found with A.28, and is equal to 0.9981. With A.27 we have $x_{11} \equiv x_{28}$ and x_{28} can be found by A.26 and A.27,

$$x_{28} = 5.1600 - 1.0000x_{31} - 0.0430x_{30} - 0.0860x_5 - 0.0430x_{12} - 0.0430x_{36}.$$

By A.25 we can obtain x_{24} as $x_{24} = 4 - x_{25}$. With A.28, A.31 and A.42 $x_{29} = 0.9881x_{31}$ and by A.29, A.38 and A.43 $x_{32} = 0.4205x_{35}$ and $x_{33} = 0.4205x_{35}$. Finally by A.38, A.43 and A.29 it is seen that $x_{34} = 0.0786x_{35}$.

Now all the state variables are expressed in the states $\{x_1, x_{30}, x_5, x_{31}, x_{12}, x_{35}, x_{16}, x_{25}, x_{36}, x_{37}\}$. At the next two pages a list of all the expressions of state variables is denoted.

List of State variables

$$\begin{aligned}x_1 &= x_1 \\x_2 &= 5 \\x_3 &= \frac{x_{30}}{(1 + 0.29)} \\x_4 &= 0.2249x_{30} \\x_5 &= x_5 \\x_6 &= 2.5391 + 0.5000x_{36} - 0.6510\sqrt{(3.9 + 0.768x_{36})^2 - 1.3578x_{36}^2} \\x_7 &= 0.2 \cdot 10^{-9}x_{36} - 5.0781 + 1.3021\sqrt{(3.9 + 0.768x_{36})^2 - 1.3578x_{36}^2} \\x_8 &= 6.4391 - 0.5000x_{36} - 0.6510\sqrt{(3.9 + 0.768x_{36})^2 - 1.3578x_{36}^2} \\x_9 &= 0.9981x_{31} \\x_{10} &= 0.0449x_{31} \\x_{11} &= 5.1591 - 1.0000x_{31} - 0.0430x_{30} - 0.0860x_5 - 0.0430x_{12} - 0.0430x_{36} \\x_{12} &= x_{12} \\x_{13} &= 0 \\x_{14} &= 0.4205x_{35} \\x_{15} &= 0.5268x_{35} \\x_{16} &= x_{16} \\x_{17} &= 2.5391 + 0.5000x_{37} - 0.6510\sqrt{(3.9 + 0.768x_{37})^2 - 1.3578x_{37}^2} \\x_{18} &= 0.2 \cdot 10^{-9}x_{37} - 5.0781 + 1.302\sqrt{(3.9 + 0.768x_{37})^2 - 1.3578x_{37}^2} \\x_{19} &= 6.4391 - 0.5000x_{37} - 0.6510\sqrt{(3.9 + 0.768x_{37})^2 - 1.358x_{37}^2} \\x_{20} &= 0.9981x_{31} \\x_{21} &= 5.1591 - 1.0000x_{31} - 0.0430x_{30} - 0.0860x_5 - 0.0430x_{12} - 0.0430x_{36} \\x_{22} &= \text{Not in the equations.} \\x_{23} &= \text{Not in the equations.} \\x_{24} &= 4 - x_{25} \\x_{25} &= x_{25} \\x_{26} &= \text{Not in the equations.} \\x_{27} &= \text{Not in the equations.} \\x_{28} &= 5.1591 - 1.0000x_{31} - 0.0430x_{30} - 0.0860x_5 - 0.0430x_{12} - 0.0430x_{36} \\x_{29} &= 0.9981x_{31}\end{aligned}$$

$$\begin{aligned}
x_{30} &= x_{30} \\
x_{31} &= x_{31} \\
x_{32} &= 0.4205x_{35} \\
x_{33} &= 0.4205x_{35} \\
x_{34} &= 0.0786x_{35} \\
x_{35} &= x_{35} \\
x_{36} &= x_{36} \\
x_{37} &= x_{37}
\end{aligned}$$

A.3.9 The reduced system

In the last two sections, respectively, the system of differential equations is stated and a list of state variables, expressed in the state variables $\{x_1, x_{30}, x_5, x_{31}, x_{12}, x_{35}, x_{16}, x_{25}, x_{36}, x_{37}\}$. These expressions can be filled in the system of differential equations. At this way a new system will be obtained, which we call the reduced system. Four terms are taken out of the set of differential equations, because of the complexity of the differential equations.

The following dynamical system is the reduced system:

$$\begin{aligned}
S &= \sqrt{(3.9 + 0.768x_{36})^2 - 1.3578x_{36}^2} \\
S_1 &= \sqrt{(3.9 + 0.768x_{37})^2 - 1.3578x_{37}^2} \\
c_{5,3} &= \frac{1}{0.0282 + 0.0054x_{36} - 0.0025 \cdot S} \\
c_{11,2} &= \frac{1}{-0.8432 + 0.2982x_{37} + 0.3034 \cdot S_1} \\
\dot{x}_1 &= 9.3158 \frac{(5 - x_1) u_1}{(3.5 + 1.4375x_1)} \\
&\quad - 9452.5106 \frac{(2.5391 + 0.5000x_{36} - 0.6510 \cdot S) x_1 u_2}{(-17.4141 + 4.3103x_{36} + 4.7216 \cdot S) (1 + 10x_1)}
\end{aligned}$$

$$\begin{aligned}
\dot{x}_{30} &= 219825.8276 \frac{(2.5391 + 0.5000x_{36} - 0.6510 \cdot S) x_1 u_2}{(-17.4141 + 4.3103x_{36} + 4.7216 \cdot S)(1 + 10x_1)} \\
&\quad - 25904.2645 \frac{x_{30}^{1.2} (2.5391 + 0.5000x_{36} - 0.6510 \cdot S) u_4}{(1 + 0.2116x_{30}^{1.2})(98.6563 + 19.2308x_{36} - 25.0401 \cdot S)} \\
\dot{x}_5 &= 25904.2645 \frac{x_{30}^{1.2} (2.5391 + 0.5000x_{36} - 0.6510 \cdot S) u_4}{(1 + 0.2116x_{30}^{1.2})(98.6563 + 19.2308x_{36} - 25.0401 \cdot S)} \\
&\quad - \frac{752.7540 (x_5 \cdot c_{5,3} - 53.0780x_{31}^2) u_5}{1 + x_5 c_{5,3} + 67.2083x_{31} + 0.4583x_5 x_{31} c_{5,3} + 44.6033x_{31}^2} \\
\dot{x}_{31} &= \frac{64.7368 (x_5 c_{5,3} - 53.0780x_{31}^2) u_5}{(1 + x_5 c_{5,3} + 67.2083x_{31} + 0.4583x_5 x_{31} c_{5,3} + 44.6033x_{31}^2)} \\
&\quad - 257.8947 \frac{(0.6654x_{31} (4 - x_{25}) - 335.00x_{12}x_{25}) u_7}{(1 + 0.2994x_{31} + 10x_{12})(9.8888 + 47.7778x_{25})} \\
&\quad - \frac{74.5614 (78.2799x_{31}x_{25})}{(1.8063 + 1.0179x_{31} - 0.0067x_{30} - 0.0134x_5 - 0.0067x_{12} - 0.0067x_{36})} \\
&\quad - \frac{(4 - x_{25})u_{13}}{(7.6667 + 65.0000x_{25})} \\
&\quad + \frac{(5.1600 - 1.0000x_{31} - 0.0430x_{30} - 0.0860x_5 - 0.0430x_{12} - 0.0430x_{36})}{(1.8063 + 1.0179x_{31} - 0.0067x_{30} - 0.0134x_5 - 0.0067x_{12} - 0.0067x_{36})} \\
&\quad - \frac{1.3570(4 - x_{25})u_{13}}{(7.6667 + 65.0000x_{25})} + 37.9773 \cdot \\
&\quad \frac{(5.1600 - 1.0000x_{31} - 0.0430x_{30} - 0.0860x_5 - 0.0430x_{12} - 0.0430x_{36})u_{15}}{(4.0353 - 0.5882x_{31} - 0.0253x_{30} - 0.0506x_5 - 0.0253x_{12} - 0.0253x_{36})} \\
\dot{x}_{12} &= 5997.5520 \frac{(0.6654x_{31} (4 - x_{25}) - 335.00x_{12}x_{25}) u_7}{(1 + 0.2994x_{31} + 10x_{12})(9.8888 + 47.7778x_{25})} \\
&\quad - 2611.1791 \frac{200x_{12} (-5.0781 + 1.3021 \cdot S) u_8}{(1 + 20x_{12} + 0.2596x_{35})(-41.0259 + 1.7242x_{36} + 10.7758 \cdot S)} \\
&\quad - 2611.1791 \frac{-0.0260x_{35} (2.5391 + 0.5000x_{36} - 0.6510 \cdot S) u_8}{(1 + 20x_{12} + 0.2596x_{35})(-41.0259 + 1.7241x_{36} + 10.7759 \cdot S)}
\end{aligned}$$

$$\begin{aligned}
\dot{x}_{35} = & 112.2807 \frac{200x_{12} (-5.0781 + 1.3021 \cdot S) u_8}{(1 + 20x_{12} + 0.2596x_{35}) (-41.0259 + 1.7241x_{36} + 10.7759 \cdot S)} \\
& + 112.2807 \frac{-0.0260x_{35} (2.5391 + 0.5000x_{36} - 0.6510 \cdot S) u_8}{(1 + 20x_{12} + 0.2596x_{35}) (-41.0259 + 1.7241x_{36} + 10.7769 \cdot S)} \\
& - 806.2360 \frac{(x_{35}c_{11,2})^{2.5}}{(1 + 0.2015 (x_{35}c_{11,2})^{2.5})} \cdot \frac{(-5.0781 + 1.3021 \cdot S_1) u_{11}}{(-43.5450 + 11.4218 \cdot S_1)}
\end{aligned}$$

$$\begin{aligned}
\dot{x}_{16} = & 842.4619 \frac{(x_{35}c_{11,2})^{2.5}}{(1 + 0.2015 (x_{35}c_{11,2})^{2.5})} \cdot \frac{(-5.0781 + 1.3021 \cdot S_1) u_{11}}{(-43.5450 + 11.4218 \cdot S_1)} \\
& - 14.9650 \frac{x_{16}u_{12}}{(1 + 0.5102x_{16})}
\end{aligned}$$

$$\begin{aligned}
\dot{x}_{25} = & 5997.5520 \frac{(0.6654x_{31} (4 - x_{25}) - 335.00x_{12}x_{25}) u_7}{(1 + 0.2994x_{31} + 10x_{12}) (9.8888 + 47.7778x_{25})} \\
& - \frac{78.2799x_{31}x_{25}}{(1.8063 + 1.0179x_{31} - 0.0067x_{30} - 0.0134x_5 - 0.0067x_{12} - 0.0067x_{36})} \\
& \cdot \frac{(4 - x_{25}) u_{13}}{(7.6667 + 65.0000x_{25})} \cdot 1733.9861 \\
& + \frac{0.0182 (5.1600 - 1.0000x_{31} - 0.0430x_{30} - 0.0860x_5 - 0.0430x_{12} - 0.0430x_{36})}{(1.8063 + 1.0179x_{31} - 0.0067x_{30} - 0.0134x_5 - 0.0067x_{12} - 0.0067x_{36})} \\
& \cdot \frac{(4 - x_{25}) u_{13}}{(7.6667 + 65.0000x_{25})} \cdot 1733.9575
\end{aligned}$$

$$\begin{aligned}
\dot{x}_{36} = & -219825.8276 \frac{(2.5391 + 0.5000x_{36} - 0.6510 \cdot S) x_1 u_2}{(-17.4141 + 4.3103x_{36} + 4.7216 \cdot S) (1 + 10x_1)} \\
& -25904.2645 \frac{x_{30}^{1.2} (2.5391 + 0.5000x_{36} - 0.6510 \cdot S) u_4}{(1 + 0.2116x_{30}^{1.2}) (98.6563 + 19.2308x_{36} - 25.0401 \cdot S)} \\
& +2611.1791 \frac{200x_{12} (-5.0781 + 1.3021 \cdot S) u_8}{(1 + 20x_{12} + 0.2596x_{35}) (-41.0259 + 1.7241x_{36} + 10.7759 \cdot S)} \\
& +2611.1791 \frac{-0.0260x_{35} (2.5391 + 0.5000x_{36} - 0.6510 \cdot S) u_8}{(1 + 20x_{12} + 0.2596x_{35}) (-41.0259 + 1.7241x_{36} + 10.7759 \cdot S)} \\
& + \frac{(5.1600 - 1.0000x_{31} - 0.0430x_{30} - 0.0860x_5 - 0.0430x_{12} - 0.0430x_{36})}{(2.0118 - 0.1961x_{31} - 0.0084x_{30} - 0.0169x_5 - 0.0084x_{12} - 0.0084x_{36})} \\
& \frac{1333.3227 (-5.0781 + 1.3021 \cdot S) u_{17}}{(-27.9542 + 2.6316x_{36} + 7.4242 \cdot S)} \\
\dot{x}_{37} = & 842.4619 \frac{(x_{35}c_{11,2})^{2.5}}{\left(1 + 0.2015 (x_{35}c_{11,2})^{2.5}\right)} \cdot \frac{(-5.0781 + 1.3021 \cdot S_1) u_{11}}{(-43.5450 + 11.4218 \cdot S_1)} \\
& -9.1661 \frac{(2.5391 + 0.5000x_{37} - 0.6510 \cdot S_1) u_{19}}{(-5.0781 + 1.3021 \cdot S_1)}
\end{aligned}$$

A.3.10 Determination of the output

To consider the output, y , it is important to know which of the variables the output variables are. For the model of glycolysis in *Trypanosoma brucei* 6 output variables are defined. The outputs of the system are:

| | |
|------------|-----------------------------|
| $x_{6(1)}$ | [ATP] _g produced |
| $x_{6(2)}$ | [ATP] _g consumed |
| x_{13} | [Glycerol] _g |
| x_{16} | [Pyruvate] _c |
| x_{17} | [ATP] _c |
| x_{22} | [H ₂ O] |

Glycerol, pyruvate, and H₂O are state variables that are only produced, while ATP produced and consumed in the glycosome and ATP in the cytosol are considered as output variables, since these are variables of interest, especially for control for drug design. The output variables can be obtained, by the rate equations. The following list of equations are the equations of

the output variables:

$$\begin{aligned}
x_{6(1)} &= r_{17}u_{17} + r_8u_8 = \\
&= c_{17,1} \frac{(x_{11}c_{17,3}x_7c_{17,4} - c_{17,2}x_{13}c_{17,5}x_6c_{17,6})u_{17}}{(1 + x_{11}c_{17,3} + x_{13}c_{17,5})(1 + x_7c_{17,4} + x_6c_{17,6})} \\
&\quad + c_{8,1} \frac{(x_{12}c_{8,3}x_7c_{8,4} - c_{8,2}x_{14}c_{8,5}x_6c_{8,6})u_8}{(1 + x_{12}c_{8,3} + x_{14}c_{8,5})(1 + x_7c_{8,4} + x_6c_{8,6})} = \\
&= 199.9967 \frac{(1.6342x_{11}x_7 - 7324.5907x_{13}x_6)u_{17}}{(1 + 0.1961x_{11} + 8.3333x_7)(1 + 8.3333x_{13} + 5.2632x_6)} \\
&\quad + 639.9894 \frac{(200x_{12}x_7 - 0.0617x_{14}x_6)u_8}{(1 + 20x_{12} + 0.6173x_{14})(1 + 10x_7 + 3.4483x_6)} = \\
&= 639.9894 \frac{200x_{12}(-5.0781 + 1.3021 \cdot S)u_8}{(1 + 20x_{12} + 0.2596x_{35})(-41.0259 + 1.7241x_{36} + 10.7759 \cdot S)} \\
&\quad + 639.9894 \frac{-0.0260x_{35}(2.5391 + 0.5000x_{36} - 0.6510 \cdot S)u_8}{(1 + 20x_{12} + 0.2596x_{35})(-41.0259 + 1.7241x_{36} + 10.7759 \cdot S)} \\
&\quad + \frac{(5.1600 - 1.0000x_{31} - 0.0430x_{30} - 0.0860x_5 - 0.0430x_{12} - 0.0430x_{36})}{(2.0118 - 0.1961x_{31} - 0.0084x_{30} - 0.0169x_5 - 0.0084x_{12} - 0.0084x_{36})} \\
&\quad \cdot \frac{199.9967(-5.0781 + 1.3021 \cdot S)u_{17}}{(-27.9542 + 2.6316x_{36} + 7.4242 \cdot S)}
\end{aligned}$$

$$\begin{aligned}
x_{6(2)} &= -r_2u_2 - r_4u_4 = \\
&= -c_{2,1} \frac{c_{2,2}x_6x_1c_{2,3}u_2}{(1 + x_6c_{2,2} + x_7c_{2,4})(1 + x_1c_{2,3})} \\
&\quad - c_{4,1} \frac{(c_{4,2}x_4)^n(c_{4,3}x_6)u_4}{(1 + (c_{4,2}x_4)^n)(1 + c_{4,3}x_6)} = \\
&= -53878.4852 \frac{x_6x_1u_2}{(1 + 8.621x_6 + 7.9365x_7)(1 + 10x_1)} \\
&\quad - 38065.5243 \frac{x_4^{1.2}x_6u_4}{(1 + 1.2689x_4^{1.2})(1 + 38.4615x_6)} = \\
&= -53878.4852 \frac{(2.5391 + 0.5000x_{36} - 0.6510 \cdot S)x_1u_2}{(-17.4141 + 4.3103x_{36} + 4.7216 \cdot S)(1 + 10x_1)} \\
&\quad - 38065.5243 \frac{x_{30}^{1.2}(2.5391 + 0.5000x_{36} - 0.6510 \cdot S)u_4}{(1 + 0.2116x_{30}^{1.2})(98.6563 + 19.2308x_{36} - 25.0401 \cdot S)}
\end{aligned}$$

$$\begin{aligned}
x_{13} &= r_{17}u_{17} = c_{17,1} \frac{(x_{11}c_{17,3}x_7c_{17,4} - c_{17,2}x_{13}c_{17,5}x_6c_{17,6})u_{17}}{(1 + x_{11}c_{17,3} + x_{13}c_{17,5})(1 + x_7c_{17,4} + x_6c_{17,6})} = \\
&= 199.9967 \frac{(1.6342x_{11}x_7 - 7324.5907x_{13}x_6)u_{17}}{(1 + 0.1961x_{11} + 8.3333x_7)(1 + 8.3333x_{13} + 5.2632x_6)} = \\
&= \frac{(5.1600 - 1.0000x_{31} - 0.0430x_{30} - 0.0860x_5 - 0.0430x_{12} - 0.0430x_{36})}{(2.0118 - 0.1961x_{31} - 0.0084x_{30} - 0.0169x_5 - 0.0084x_{12} - 0.0084x_{36})} \\
&\cdot \frac{199.9967(-5.0781 + 1.3021 \cdot S)u_{17}}{(-27.9542 + 2.6316x_{36} + 7.4242 \cdot S)}
\end{aligned}$$

$$\begin{aligned}
x_{16} &= r_{11}u_{11} = c_{11,1} \frac{(c_{11,2}x_{15})^n(c_{11,3}x_{18})u_{11}}{(1 + (c_{11,2}x_{15})^n)(1 + c_{11,3}x_{18})} = \\
&= \frac{22806.94 \left(\frac{x_{15}}{0.34+0.5965x_{17}+0.5313x_{18}} \right)^{2.5} x_{18}u_{11}}{\left(1 + \left(\frac{x_{35}}{0.34+0.5965x_{17}+0.5313x_{18}} \right)^{2.5} \right) (1 + 8.7719x_{18})} = \\
&= 4595.5454 \frac{(x_{35}c_{11,2})^{2.5}}{(1 + 0.2015(x_{35}c_{11,2})^{2.5})}
\end{aligned}$$

$$c_{11,2} = \frac{1}{-0.8432 + 0.2982x_{37} + 0.3034\sqrt{(3.9 + 0.768x_{37})^2 - 1.3578x_{37}^2}}$$

$$\begin{aligned}
x_{17} &= r_{11}u_{11} = \\
&= c_{11,1} \frac{(c_{11,2}x_{15})^n(c_{11,3}x_{18})}{(1 + (c_{11,2}x_{15})^n)(1 + c_{11,3}x_{18})} \\
&= 22804.27546 \frac{\left(\frac{x_{15}}{0.34+0.5965x_{17}+0.5313x_{18}} \right)^{2.5} x_{18}u_{11}}{\left(1 + \left(\frac{x_{15}}{0.34+0.5965x_{17}+0.5313x_{18}} \right)^{2.5} \right) (1 + 8.7719x_{18})} \\
&= 4595.5454 \frac{(x_{35}c_{11,2})^{2.5}}{(1 + 0.2015(x_{35}c_{11,2})^{2.5})}
\end{aligned}$$

$$c_{11,2} = \frac{1}{-0.8432 + 0.2982x_{37} + 0.3034\sqrt{(3.9 + 0.768x_{37})^2 - 1.3578x_{37}^2}}$$

$$x_{22} = r_{15}u_{15} = c_{15,1} \frac{c_{15,2}x_{21}u_{15}}{1 + c_{15,2}x_{21}} = 216.4576 \frac{x_{21}u_{15}}{1 + 0.5882x_{21}} = 216.4576u_{15} \cdot$$

$$\frac{(5.1591 - 1.000x_{31} - 0.0430x_{30} - 0.0860x_5 - 0.0430x_{12} - 0.0430x_{36})}{(4.0346 - 0.5882x_{31} - 0.0253x_{30} - 0.0506x_5 - 0.0253x_{12} - 0.0253x_{36})}$$

A.4 Positivity of the system

A system is called positive if all state variables are contained in the positive orthant, with other words they are all positive. To investigate whether the system is positive the boundaries are considered, $\frac{dx_i}{dt}$ when $x_i = 0$. The reduced system is called positive if $\forall i \in \{1, 30, 5, 31, 12, 35, 16, 25, 36, 37\}$ $\frac{dx_i}{dt} \geq 0$ if $x_i = 0$, [29, p.20, (2.1.2), (2.1.3)]. So when this holds $x_i = 0$ is an under boundary for the reduced system. Since the other state variables can be expressed in these ten state variables, they also have to be considered. By considering these other state variables upper boundaries for x_{36} and x_{37} arise, these upper boundaries also arise when the square roots in the differential equations are considered. There are also a few other restrictions that arise. Positivity of the system will be checked for the system below.

Positivity of the reduced system

When $x_1 = 0$, the following equation for $\frac{dx_1}{dt}$ is obtained:

$$\frac{dx_1}{dt} = 9.3158 \frac{x_2 u_1}{1.0 + 0.5 x_2}.$$

It is known that x_2 is a positive concentration and $u_i \geq 0$ $\forall i \in \{1, 30, 5, 31, 12, 35, 16, 25, 36, 37\}$, so $\frac{dx_1}{dt} \geq 0$. The following differential equation for x_{30} is obtained:

$$\begin{aligned} \frac{dx_{30}}{dt} = & 219825.8276 \frac{x_6 x_1 u_2}{(1 + 8.6207 x_6 + 7.9365 x_7)(1 + 10 x_1)} \\ & - 155310.6798 \frac{x_4^{1.2} x_6 u_4}{(1 + 1.2689 x_4^{1.2})(1 + 38.4615 x_6)}. \end{aligned}$$

In this equation x_{30} does not occur, but $x_4 = 0.2248 x_{30}$. So when $x_{30} = 0$ also $x_4 = 0$ and for $\frac{dx_{30}}{dt}$ the following holds:

$$\frac{dx_{30}}{dt} = 219825.8276 \frac{x_6 x_1 u_2}{(1 + 8.6207 x_6 + 7.9365 x_7)(1 + 10 x_1)}.$$

Since the enzyme concentrations and the state concentrations are greater than or equal to zero it is found that $\frac{dx_{30}}{dt}$ is greater than or equal to zero if x_{30} is zero. The differential equation for x_5 is

$$\begin{aligned} \frac{dx_5}{dt} = & 155310.6798 \frac{x_4^{1.2} x_6 u_4}{(1 + 1.2689 x_4^{1.2})(1 + 38.4615 x_6)} \\ & + 891320.6299 \frac{x_9 x_{10} u_5}{1.0 + 14.9254 x_{10} + 66.6667 x_9 + 995.0249 x_9 x_{10}}, \end{aligned}$$

if $x_5 = 0$. This equation is greater than or equal to zero and thus $\frac{dx_5}{dt} \geq 0$ if $x_5 = 0$. The state variable x_{31} does not occur in $\frac{dx_{31}}{dt}$,

$$\begin{aligned} \frac{dx_{31}}{dt} = & \frac{64.7368 (c_{53}x_5 - 1184.0796x_9x_{10}) u_5}{1 + c_{53}x_5 + x_{10}(14.9254 + 10.2041x_5c_{53} + 995.0249x_9) + 66.6667x_9} \\ & - 257.8947 \frac{(14.8148x_{10}x_{24} - 335.0000x_{12}x_{25}) u_7}{(1 + 6.6667x_{10} + 10x_{12})(1 + 2.2222x_{24} + 50x_{25})} \\ & - \frac{74.5614 (78.4314x_9 x_{25} - 0.0182x_{11}x_{24}) u_{13}}{(1 + 1.1765x_9 + 0.1563x_{11})(1 + 66.6667x_{25} + 1.6667x_{24})} \\ & + 37.9773 \frac{x_{21} u_{15}}{1 + 0.5882 x_{21}}, \end{aligned}$$

with

$$c_{53} = \frac{1}{0.0282 + 0.0054x_{36} - 0.0025\sqrt{\left((3.9 + 0.768x_{36})^2 - 1.3578x_{36}^2\right)}}.$$

Since $x_9 = 0.9981x_{31}$ and $x_{10} = 0.0449x_{31}$ the following is obtained for $\frac{dx_{31}}{dt}$ when $x_{31} = 0$:

$$\begin{aligned} \frac{dx_{31}}{dt} = & 64.7368 \frac{c_{53} x_5 u_5}{1.0 + c_{53} x_5} \\ & + 86394.7369 \frac{x_{12} x_{25} u_7}{(1.0 + 10 x_{12})(1 + 2.2222 x_{24} + 50 x_{25})} \\ & + 1.3592 \frac{x_{11} x_{24} u_{13}}{(1.0 + 0.1563 x_{11})(1 + 66.6667 x_{25} + 1.6667 x_{24})} \\ & + 37.9773 \frac{x_{21} u_{15}}{1 + 0.5882 x_{21}}. \end{aligned}$$

All factors in this differential equation have a positive sign, which means that $\frac{dx_{31}}{dt} \geq 0$ when $x_{31} = 0$. As $x_{12} = 0$, the differential equation for x_{12} ,

$$\begin{aligned} \frac{dx_{12}}{dt} = & 88852.6225 \frac{x_{10} x_{24} u_7}{(1 + 6.6667 x_{10})(1 + 2.2222 x_{24} + 50 x_{25})} \\ & + 161.1839 \frac{x_{14} x_6 u_8}{(1 + 0.6173 x_{14})(1 + 10 x_7 + 3.4483 x_6)}, \end{aligned}$$

is greater than or equal to zero. The differential equation

$$\begin{aligned} \frac{dx_{35}}{dt} = & 112.2807 \frac{(200 x_{12} x_7 - 0.0617 x_{14} x_6) u_8}{(1 + 20 x_{12} + 0.6173 x_{14}) (1 + 10 x_7 + 3.4483 x_6)} \\ & - 4001.2311 \frac{\left(\frac{x_{15}}{0.34+0.5965 x_{17}+0.5313 x_{18}} \right)^{2.5} x_{18} u_{11}}{\left(1 + \left(\frac{x_{15}}{0.34+0.5965 x_{17}+0.5313 x_{18}} \right)^{2.5} \right) (1 + 8.7719 x_{18})} \end{aligned}$$

does not contain x_{35} , but both x_{14} and x_{15} are zero if $x_{35} = 0$, since $x_{14} = 0.4205x_{35}$ and $x_{15} = 0.5268x_{35}$. This means

$$\frac{dx_{35}}{dt} = 22456.1404 \frac{x_{12} x_7 u_8}{(1.0 + 20 x_{12}) (1 + 10 x_7 + 3.4483 x_6)},$$

if $x_{35} = 0$. All terms in this equation have a positive sign, and $c_{5,3} > 0$ if $x_{36} \in (0, 7.8000)$. It shall be obtained that x_{36} is indeed contained inside this range. This means that $\frac{dx_{35}}{dt} \geq 0$ if $x_{35} = 0$. If $x_{16} = 0$ the differential equation for x_{16} ,

$$\frac{dx_{16}}{dt} = 4181.0148 \frac{\left(\frac{x_{15}}{0.34+0.5965 x_{17}+0.5313 x_{18}} \right)^{2.5} x_{18} u_{11}}{\left(1 + \left(\frac{x_{15}}{0.34+0.5965 x_{17}+0.5313 x_{18}} \right)^{2.5} \right) (1 + 8.7719 x_{18})},$$

is greater than or equal to zero. When $x_{25} = 0$, the following equation for $\frac{dx_{25}}{dt}$ is obtained:

$$\begin{aligned} \frac{dx_{25}}{dt} = & 88852.7225 \frac{x_{10} x_{24} u_7}{(1 + 6.6667 x_{10} + 10 x_{12}) (1 + 2.2222 x_{24})} \\ & + 31.6091 \frac{x_{11} x_{24} u_{13}}{(1 + 1.1765 x_9 + 0.1563 x_{11}) (1.0 + 1.6667 x_{24})}. \end{aligned}$$

This differential equation is greater than or equal to zero since the enzyme and state concentrations are greater than or equal to zero. In the following differential equation for x_{36} , x_{36} does not occur:

$$\begin{aligned} \frac{dx_{36}}{dt} = & -219825.8276 \frac{x_6 x_1 u_2}{(1 + 8.6207 x_6 + 7.9365 x_7) (1 + 10 x_1)} \\ & - 155310.6798 \frac{x_4^{1.2} x_6 u_4}{(1 + 1.2689 x_4^{1.2}) (1 + 38.4615 x_6)} \\ & + 2611.1791 \frac{(200 x_{12} x_7 - 0.0617 x_{14} x_6) u_8}{(1 + 20 x_{12} + 0.6173 x_{14}) (1 + 10 x_7 + 3.4483 x_6)} \\ & + 815.9935 \frac{(1.6340 x_{11} x_7 - 7324.5614 x_{13} x_6) u_{17}}{(1 + 0.1961 x_{11} + 8.3333 x_{13}) (1 + 8.3333 x_7 + 5.2632 x_6)} \end{aligned}$$

Since both x_6 and x_7 are depending of x_{36} in such a way that $x_6 = 0$ and $x_7 = 0$ if $x_{36} = 0$ it follows that $\frac{dx_{36}}{dt} = 0$, when $x_{36} = 0$. For x_{37} we have

$$\frac{dx_{37}}{dt} = 4181.0148 \frac{\left(\frac{x_{15}}{0.34+0.5965 x_{17}+0.5313 x_{18}}\right)^{2.5} x_{18} u_{11}}{\left(1 + \left(\frac{x_{15}}{0.34+0.5965 x_{17}+0.5313 x_{18}}\right)^{2.5}\right) (1 + 8.7719 x_{18})} - 9.1661 \frac{x_{17} u_{19}}{x_{18}}.$$

In this differential equation x_{37} does not occur, but x_{17} depends in such a way of x_{37} , that if $x_{37} = 0$ also $x_{17} = 0$. When x_{17} is zero the following equation for $\frac{dx_{37}}{dt}$ is obtained:

$$\frac{dx_{37}}{dt} = 4181.0148 \frac{\left(\frac{x_{15}}{0.34+0.5313 x_{18}}\right)^{2.5} x_{18} u_{11}}{\left(1 + \left(\frac{x_{15}}{0.34+0.5313 x_{18}}\right)^{2.5}\right) (1 + 8.7719 x_{18})}.$$

This differential equation is greater than or equal to zero. It has been obtained that all state variables, in $\{x_1, x_{30}, x_5, x_{31}, x_{12}, x_{35}, x_{16}, x_{25}, x_{36}, x_{37}\}$ are ≥ 0 . In next part of this section upper boundaries and restrictions for the system are considered.

Upper boundaries and restrictions for the system

Since $x_6 = 2.5391 + 0.5000x_{36} - 0.6510\sqrt{(3.9 + 0.768x_{36})^2 - 1.3578x_{36}^2}$ it is obtained that $x_6 \geq 0$ if $x_{36} \in (-2.0173, 9.8173)$, and it is also obtained that $x_{36} \geq 0$. Since $x_8 = 6.4391 - 0.5000x_{36} - 0.6510\sqrt{(3.9 + 0.768x_{36})^2 - 1.3578x_{36}^2}$, the same upper boundary is found for x_{36} . But by considering $x_7 = -5.0781 + 1.3021\sqrt{(3.9 + 0.768x_{36})^2 - 1.3578x_{36}^2}$ it is obtained that this is greater than or equal to zero if $x_{36} \in (0, 7.8000)$. Thus when $x_{36} \in (0, 7.8000)$, $x_6 \geq 0$, $x_7 \geq 0$, and $x_8 \geq 0$. When $x_{36} = 7.8000$, $\frac{dx_{36}}{dt}$ has to be less than or equal to zero. When $x_{36} = 7.8000$, $x_6 = 3.9$, $x_7 = 0$, and $x_8 = 0$, then the following

is obtained for $\frac{dx_{36}}{dt}$:

$$\begin{aligned}\frac{dx_{36}}{dt} = & -24763.2481 \frac{x_1 u_2}{1 + 10 x_1} \\ & -4011.3354 \frac{x_4^{1.2} u_4}{1 + 1.2689 x_4^{1.2}} \\ & -43.5081 \frac{x_{14} u_8}{1 + 20x_{12} + 0.6173x_{14}} \\ & -0.1083 \cdot 10^7 \frac{x_{13} u_{17}}{1 + 0.1961x_{11} + 8.3333x_{13}}.\end{aligned}$$

One can see that all terms have negative signs, which means that $\frac{dx_{36}}{dt} \leq 0$ and this means that $x_{36} \in (0, 7.8000)$. The state variables x_{17} , x_{18} and x_{19} depend on x_{37} at the same way as x_6 , x_7 and x_8 depend on x_{36} . So for x_{18} to be greater than or equal to zero, x_{37} has to be in $(0, 7.8000)$. Thus when $x_{37} = 7.8000$, $\frac{dx_{37}}{dt}$ has to be less than or equal to zero. The following differential equation for x_{37} is considered:

$$\begin{aligned}\frac{dx_{37}}{dt} = & 842.4619 \frac{(x_{35} c_{11,2})^{2.5}}{\left(1 + 0.2015 (x_{35} c_{11,2})^{2.5}\right)} \\ & \cdot \frac{(-5.0781 + 1.3021 \cdot S_1) u_{11}}{(-43.5450 + 11.4218 \cdot S_1)} \\ & -9.1661 \frac{(2.5391 + 0.5000x_{37} - 0.6510 \cdot S_1) u_{19}}{(-5.0781 + 1.3021 \cdot S_1)},\end{aligned}$$

with

$$S_1 = \sqrt{(3.9 + 0.768x_{37})^2 - 1.3578x_{37}^2},$$

and

$$c_{11,2} = \frac{1}{-0.8435 + 0.2983x_{37} + 0.3035 \cdot S_1}.$$

Since $c_{11,2} \geq 0$ if $x_{37} \in (-0.5992, 9.8173)$ it is also ≥ 0 if $x_{37} = 7.8000$. So then it is clear that

$$\frac{842.4619 (x_{35} c_{11,2})^{2.5} u_{11}}{\left(1 + 0.2015 (x_{35} c_{11,2})^{2.5}\right)} \geq 0$$

if $x_{37} = 7.8000$. When the numerator and the denominator of

$$\frac{(-5.0781 + 1.3021 \cdot S_1) u_{11}}{(-43.5450 + 11.4218 \cdot S_1)}$$

are considered, one can see that the numerator is equal to zero if $x_{37} = 7.8000$ and the denominator is greater than zero, namely 3.9. By this the first term of the differential equation for x_{37} is zero when $x_{37} = 7.8000$. When the second term of $\frac{dx_{37}}{dt}$ is less than or equal to zero then $\frac{dx_{37}}{dt} \leq 0$. The numerator, $9.1650(2.5391 + 0.5000x_{37} - 0.6510 \cdot S_1) > 0$ if $x_{37} \in (-2.0173, 9.8173)$. Thus when $x_{37} = 7.8000$ this is also greater than zero. When $x_{37} \uparrow 7.8000$, the denominator, $(-5.0781 + 1.3021 \cdot S_1) \downarrow 0$, so

$$\lim_{x_{37} \uparrow 7.8000} -9.1650 \frac{(2.5391 + 0.5000x_{37} - 0.6510 \cdot S_1)u_{19}}{(-5.0781 + 1.3021 \cdot S_1)} = -\infty,$$

and when $x_{37} \in (0, 7.8000)$ this fraction is less than zero. So $\frac{dx_{37}}{dt} \leq 0$ when $x_{37} = 7.8000$ and thus $x_{37} \in (0, 7.8000)$ and $x_{18} \geq 0$. The above explanation is also explained by the following figure.

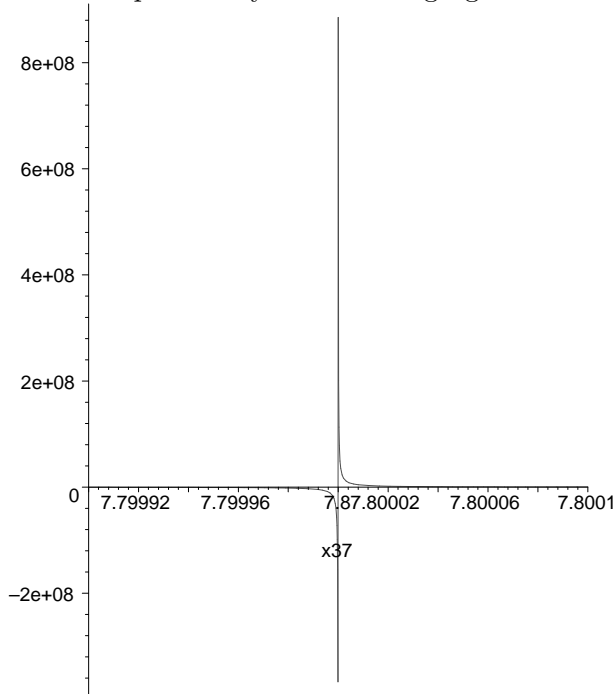

Since it is known that $x_{24} = 4 - x_{25}$, x_{25} has to be less than or equal to 4 for x_{24} to be greater than or equal to zero. This is the case when the differential equation for x_{25} is less than or equal to zero when it happens x_{25} to be 4. When $x_{25} = 4$ and $x_{24} = 0$ the following is obtained for $\frac{dx_{25}}{dt}$:

$$\begin{aligned} \frac{dx_{25}}{dt} = & -39983.6801 \frac{x_{12}u_7}{1 + 6.6667x_{10} + 10x_{12}} \\ & -2032.3623 \frac{x_9u_{13}}{1 + 1.1765x_9 + 0.1563x_{11}}. \end{aligned}$$

Since both signs are negative $\frac{dx_{25}}{dt} \leq 0$ and by this $x_{25} \in (0, 4)$.

The only variables that have to be considered are x_{11} , x_{21} and x_{28} . It is known that

$$\begin{aligned} x_{11} &= 5.1600 - x_{31} - 0.0430x_{30} - 0.0860x_5 - 0.0430x_{12} - 0.0430x_{36} = \\ &= 5.1600 - 0.0430 \left(\frac{x_{31}}{0.0430} + x_{30} + 2x_5 + x_{12} + x_{36} \right). \end{aligned} \quad (\text{A.45})$$

We define: $\left(\frac{x_{31}}{0.0430} + x_{30} + 2x_5 + x_{12} + x_{36} \right) := f(x_{31}, x_{30}, x_5, x_{12}, x_{36})$, here called f , has to be less than 120. The differential equation for f is

$$\frac{df}{dt} = \frac{1}{0.0430} \frac{dx_{31}}{dt} + \frac{dx_{30}}{dt} + 2 \frac{dx_5}{dt} + \frac{dx_{12}}{dt} + \frac{dx_{36}}{dt},$$

this equation has to be less than or equal to zero when $f=119.9791$. Now the differential equations for x_{31} , x_{30} , x_5 , x_{12} and x_{36} are used as follows to find $\frac{df}{dt}$:

$$\begin{aligned} \frac{1}{0.0430} \frac{dx_{31}}{dt} &= \frac{0.1754}{0.0430} (2r_5u_5 - r_7u_7 - r_{13}u_{13} + r_{15}u_{15}) \\ \frac{dx_{30}}{dt} &= 4.0799(r_2u_2 - r_4u_4) \\ 2 \frac{dx_5}{dt} &= 2 \cdot 4.0799(r_4u_4 - r_5u_5) \\ \frac{dx_{12}}{dt} &= 4.0799(r_7u_7 - r_8u_8) \\ \frac{dx_{36}}{dt} &= 4.0799(-r_2u_2 - r_4u_4 + u_8r_8 + r_{17}u_{17}). \end{aligned}$$

When these equations are used it follows that

$$\begin{aligned} \frac{df}{dt} &= 4.0799(r_{15}u_{15} + r_{17}u_{17} - r_{13}u_{13}) = \\ &= 883.1929 \frac{x_{21}u_{15}}{1 + 0.5882x_{21}} \\ &\quad + 815.9935 \frac{(1.6340x_{11}x_7 - 7324.5614x_{13}x_6) u_{17}}{(1 + 0.1961x_{11} + 8.3333x_{13})(1 + 8.3333x_7 + 5.2632x_6)} \\ &\quad - 1733.9861 \frac{(78.4314x_9x_{25} - 0.0182x_{11}x_{24}) u_{13}}{(1 + 1.1765x_9 + 0.1563x_{11})(1 + 66.6667x_{25} + 1.6667x_{24})} \\ &= -135998.9120 \frac{x_9x_{25}u_{13}}{(1 + 1.1765x_9)(1 + 66.6667x_{25} + 1.6667x_{24})}. \end{aligned}$$

Since x_{13} is assumed to be zero and $x_{11} = 0$ and $x_{21} = 0$ if $f = 120$ by (A.45), this equation is less or equal to zero.

The conclusion is that the dynamical system for the glycolysis in *Trypanosoma brucei* is positive, since all the state variables are contained in the positive orthant.

A.5 Steady state of the system

In this section the results of the discussion about steady state for glycolysis in *Trypanosoma brucei* will be denoted. First the graph of the system will be determined, since this graph is discussed in Section 4.4. In Section 4.6 determining steady state for the system is discussed. In Appendix A.5.2 the Matlab files, used to determine a steady state numerical, are denoted. In this appendix also the results under aerobic and under anaerobic conditions, in the form of tables and in the form of figures as well.

A.5.1 Graph of the system

As defined in Definition 4.11, an edge (i, k) in the graph is a directed edge from node k to node i , if \dot{x}_i depends on x_k , or $y(t)$ depends on x_k .

In table A.5.1 is denoted, which differential equation, depend on which states. First two tables of the state and the input variables, which are considered in the graph, are given below as a reminder.

| | | | |
|----------|---------------------------|----------|-------------------|
| x_1 | [Glc] _g | u_1 | Glucose transport |
| x_{30} | [Hexose-P] _g | u_2 | HK |
| x_5 | [Fru-1,6-BP] _g | u_4 | PFK |
| x_{31} | [Triose-P] | u_5 | ALD |
| x_{12} | [1,3-BPGA] _g | u_7 | GAPDH |
| x_{35} | [N] | u_8 | PGK |
| x_{16} | [Pyruvate] _c | u_{11} | PYK |
| x_{25} | [NADH] _g | u_{13} | GDH |
| x_{36} | [P] _g | u_{15} | GPO |
| x_{37} | [P] _c | u_{17} | GK |
| | | u_{19} | ATP utalization |

The results are denoted for both the dynamical system containing all state variables, denoted by system, and the reduced system. Which input variable belongs to which differential equation is also denoted in the table. In the table ODE stands for Ordinary Differential Equation.

Table A.5.1: the depending of the system of the states

| ODE | System | u_i | Reduced system |
|----------------|-----------------------------------|----------|---|
| \dot{x}_1 | x_2, x_1 | u_1 | x_1 |
| | x_6, x_1, x_7 | u_2 | x_{36}, x_1 |
| \dot{x}_{30} | x_6, x_1, x_7 | u_2 | x_{36}, x_1 |
| | x_4, x_6 | u_4 | x_{30}, x_{36} |
| \dot{x}_5 | x_4, x_6 | u_4 | x_{30}, x_{36} |
| | $x_5, x_9, x_{10}, x_6, x_7, x_8$ | u_5 | x_5, x_{36}, x_{31} |
| \dot{x}_{31} | $x_5, x_9, x_{10}, x_6, x_7, x_8$ | u_5 | x_5, x_{36}, x_{31} |
| | $x_{10}, x_{24}, x_{12}, x_{25}$ | u_7 | x_{31}, x_{25}, x_{12} |
| | $x_9, x_{25}, x_{11}, x_{24}$ | u_{13} | $x_{31}, x_{25}, x_{30}, x_{12}, x_{36}, x_5$ |
| | x_{21} | u_{15} | $x_{31}, x_{30}, x_5, x_{12}, x_{36}$ |
| \dot{x}_{12} | $x_{10}, x_{24}, x_{12}, x_{25}$ | u_7 | x_{31}, x_{25}, x_{12} |
| | x_{12}, x_7, x_{14}, x_6 | u_8 | x_{12}, x_{36}, x_{35} |
| \dot{x}_{35} | x_{12}, x_7, x_{14}, x_6 | u_8 | x_{12}, x_{36}, x_{35} |
| | x_{15}, x_{17}, x_{18} | u_{11} | x_{35}, x_{37} |
| \dot{x}_{16} | x_{15}, x_{17}, x_{18} | u_{11} | x_{35}, x_{37} |
| | x_{16} | u_{12} | x_{16} |
| \dot{x}_{25} | $x_{10}, x_{24}, x_{12}, x_{25}$ | u_7 | x_{31}, x_{25}, x_{12} |
| | $x_9, x_{25}, x_{11}, x_{24}$ | u_{13} | $x_{31}, x_{25}, x_{30}, x_{12}, x_5, x_{36}$ |
| \dot{x}_{36} | x_6, x_1, x_7 | u_2 | x_{36}, x_1 |
| | x_4, x_6 | u_4 | x_{30}, x_{36} |
| | x_{12}, x_7, x_{14}, x_6 | u_8 | x_{12}, x_{36}, x_{35} |
| | x_{11}, x_7, x_{13}, x_6 | u_{17} | $x_5, x_{36}, x_{12}, x_{30}, x_{31}$ |
| \dot{x}_{37} | x_{15}, x_{17}, x_{18} | u_{11} | x_{35}, x_{37} |
| | x_{17}, x_{18} | u_{19} | x_{37} |

The following table is a table of edges, and labels of the edges, which are the input variables. The edges are ordered to differential equation.

Table A.5.2: edges and labels of edges for the system

| | Edges | u_i | | Edges | u_i |
|----|--------------|----------------------------|----------|------------------|-------------------------|
| 1 | (1, 1) | u_1, u_2 | 35 | (12, 35) | u_8 |
| | (36, 1) | u_2 | | (36, 35) | u_8 |
| 30 | (1, 30) | u_2 | 16 | (35, 35) | u_8, u_{11} |
| | (30, 30) | u_4 | | (37, 35) | u_{11} |
| | (36, 30) | u_2, u_4 | | (35, 16) | u_{11} |
| 5 | (30, 5) | u_4 | 25 | (37, 16) | u_{11} |
| | (36, 5) | u_4, u_5 | | (16, 16) | u_{12} |
| | (5, 5) | u_5 | | (31, 25) | u_7, u_{13} |
| | (31, 5) | u_5 | | (25, 25) | u_7, u_{13} |
| 31 | (5, 31) | u_5, u_{13}, u_{15} | 36 | (12, 25) | u_7, u_{13} |
| | (36, 31) | u_5, u_{13}, u_{15} | | (30, 25) | u_{13} |
| | (31, 31) | u_5, u_7, u_{13}, u_{15} | | (5, 25) | u_{13} |
| | (25, 31) | u_7, u_{13} | | (36, 25) | u_{13} |
| | (12, 31) | u_7, u_{13}, u_{15} | | (36, 36) | u_2, u_4, u_8, u_{17} |
| | (30, 31) | u_{13}, u_{15} | | (1, 36) | u_2 |
| 12 | (31, 12) | u_7 | 37 | (30, 36) | u_4, u_{17} |
| | (25, 12) | u_7 | | (12, 36) | u_8, u_{17} |
| | (12, 12) | u_7, u_8 | | (35, 36) | u_8 |
| | (36, 12) | u_8 | | (5, 36) | u_{17} |
| | (35, 12) | u_8 | | (31, 36) | u_{17} |
| | | | | | (35, 37) |
| | | | (37, 37) | u_{11}, u_{19} | |

The output variables are also obtained in the graph. The following variables are outputs of the system:

| | |
|------------|-----------------------------|
| $x_{6(1)}$ | [ATP] _g produced |
| $x_{6(2)}$ | [ATP] _g consumed |
| x_{13} | [Glycerol] _g |
| x_{16} | [Pyruvate] _c |
| x_{17} | [ATP] _c |
| x_{22} | [H ₂ O] |

In table A.5.3 is denoted, which output variables, depend on which states.

Table A.5.3: the depending of the output variables of the states

| | System | u_i | Reduced system |
|----------|----------------------------|----------|---------------------------------------|
| x_{16} | x_{15}, x_{17}, x_{18} | u_{11} | x_{35}, x_{37} |
| x_{22} | x_{21} | u_{15} | $x_{31}, x_{30}, x_5, x_{12}, x_{36}$ |
| $x_6(1)$ | x_{12}, x_7, x_{14}, x_6 | u_8 | x_{36}, x_{35}, x_{12} |
| | x_{11}, x_7, x_{13}, x_6 | u_{17} | $x_{31}, x_{30}, x_5, x_{12}, x_{36}$ |
| $x_6(2)$ | x_6, x_1, x_7 | u_2 | x_{36}, x_1 |
| | x_4, x_6 | u_4 | x_{30}, x_{36} |
| x_{17} | x_{15}, x_{17}, x_{18} | u_{11} | x_{35}, x_{37} |
| x_{13} | x_{11}, x_7, x_{13}, x_6 | u_{17} | $x_{31}, x_{30}, x_5, x_{12}, x_{36}$ |

The extra edges that have to be add to the graph, with respect to the output variables are stated in Table A.5.3.

Table A.5.4: edges and labels of edges for the output variables

| | Edges | u_i | | Edges | u_i |
|----------|--------------|----------|-----------|--------------|---------------|
| x_{22} | (31, 22) | u_{15} | $x_6(2)$ | (30, 6(2)) | u_4 |
| | (30, 22) | u_{15} | | (36, 6(2)) | u_4, u_2 |
| | (5, 22) | u_{15} | | (1, 6(2)) | u_2 |
| | (12, 22) | u_{15} | $x_6(1)$ | (36, 6(1)) | u_8, u_{17} |
| | (36, 22) | u_{15} | | (35, 6(1)) | u_8 |
| x_{13} | (31, 13) | u_{17} | | (12, 6(1)) | u_8, u_{17} |
| | (30, 13) | u_{17} | | (31, 6(1)) | u_{17} |
| | (5, 13) | u_{17} | | (30, 6(1)) | u_{17} |
| | (12, 13) | u_{17} | (5, 6(1)) | u_{17} | |
| | (36, 13) | u_{17} | | | |
| x_{17} | (35, 17) | u_{11} | | | |
| | (37, 17) | u_{11} | | | |

```

function F=tryprbruc(t,y)

u1=1;
u2=1;
u4=1;
u5=1;
u7=1;
u13=1;
u15=1;
u8=1;
u11=1;
u12=1;
u17=0;
u19=1;
%x1=y(1);
%x30=y(2);
%x5=y(3);
%x31=y(4);
%x12=y(5);
%x35=y(6);
%x16=y(7);
%x25=y(8);
%x36=y(9);
%x37=y(10);

S=sqrt((3.9+.768*y(9))^2-1.357824*y(9)^2);
S1=sqrt((3.9+.768*y(10))^2-1.357824*y(10)^2);

dx1=9.315789474*(5-y(1))*u1/(3.5+1.4375*y(1))-9452.510586*...
    (2.539062500+.5*y(9)-.6510416665*S)*y(1)*u2/((-17.4141...
    0954+4.310344828*y(9)+4.721566551*S)*(1+10*y(1)));

dx30 = 219825.8276*(2.539062500+.5*y(9)-.6510416665*S)*y(1...
    )*u2/((-17.41410954+4.310344828*y(9)+4.721566551*S)...
    *(1+10*y(1)))-25904.26449*y(2)^1.2*(2.539062500+.5*...
    y(9)-.6510416665*S)*u4/((1+.2116378409*y(2)^1.2)*(9...
    8.65625000+19.23076923*y(9)-25.04006410*S));

dx5=25904.26449*y(2)^1.2*(2.539062500+.5*y(9)-.6510416665*...
    S)*u4/((1+.2116378409*y(2)^1.2)*(98.65625000+19.230769...
    23*y(9)-25.04006410*S))-752.7539779*(y(3)/(.2821540919...
    e-1+.5384770348e-2*y(9)-.2461274573e-2*S)-53.07797156*...
    y(4)^2)*u5/(1+y(3)/(.2821540919e-1+.5384770348e-2*y(9)...
    -.2461274573e-2*S)+67.20826047*y(4)+.4582968690*y(3)*y...

```

$$(4)/(.2821540919e-1+.5384770348e-2*y(9)-.2461274573e-2... *S)+44.60333747*y(4)^2);$$

$$\begin{aligned} dx31= & 64.73684211*(y(3)/(.2821540919e-1+.5384770348e-2*y(9)... \\ & -.2461274573e-2*S)-53.07797156*y(4)^2)*u5/(1+y(3)/(.2... \\ & 821540919e-1+.5384770348e-2*y(9)-.2461274573e-2*S)+67... \\ & .20826047*y(4)+.4582968690*y(3)*y(4)/(.2821540919e-1+... \\ & .5384770348e-2*y(9)-.2461274573e-2*S)+44.60333747*y(4... \\ &)^2)-257.8947369*(.6653791579*y(4)*(4-y(8))-335.00*y(... \\ & 5)*y(8))*u7/((1+.2994206211*y(4)+10*y(5))*(9.88888888... \\ & 8+47.77777778*y(8)))-74.56140351*(78.27990093*y(4)*y(... \\ & 8)-.1822916667e-1*(5.160000001-1.000000000*y(4)-.4300... \\ & 000001e-1*y(2)-.8600000002e-1*y(3)-.4300000001e-1*y(5... \\ &)-.4300000001e-1*y(9))*(4-y(8))*u13/((1.806250000+1... \\ & 017948514*y(4)-.6718750002e-2*y(2)-.1343750000e-1*y(3... \\ &)-.6718750002e-2*y(5)-.6718750002e-2*y(9))*(7.6666666... \\ & 68+65.00000000*y(8)))+37.97729618*(5.160000001-1.0000... \\ & 00000*y(4)-.4300000001e-1*y(2)-.8600000002e-1*y(3)-.4... \\ & 300000001e-1*y(5)-.4300000001e-1*y(9))*u15/(4.0352941... \\ & 18-.5882352941*y(4)-.2529411765e-1*y(2)-.5058823530e... \\ & 1*y(3)-.2529411765e-1*y(5)-.2529411765e-1*y(9)); \end{aligned}$$

$$\begin{aligned} dx12= & 5997.552019*(.6653791579*y(4)*(4-y(8))-335.00*y(5)*y(8... \\ &))*u7/((1+.2994206211*y(4)+10*y(5))*(9.888888888+47.77... \\ & 777778*y(8)))-2611.179110*(200*y(5)*(-5.078125000+1.30... \\ & 2083333*S)-.2595828537e-1*y(6)*(2.539062500+.5*y(9)-.6... \\ & 510416665*S))*u8/((1+20*y(5)+.2595828536*y(6))*(-41.02... \\ & 586207+10.77586207*S+1.724137931*y(9))); \end{aligned}$$

$$\begin{aligned} dx35= & 112.2807018*(200*y(5)*(-5.078125000+1.302083333*S)-.25... \\ & 95828537e-1*y(6)*(2.539062500+.5*y(9)-.6510416665*S))*... \\ & u8/((1+20*y(5)+.2595828536*y(6))*(-41.02586207+10.7758... \\ & 6207*S+1.724137931*y(9)))-806.2360378*(y(6)/(-.8432253... \\ & 97+.2982456141*y(10)+.3033911275*S1))^2.5*(-5.07812500... \\ & 0+1.302083333*S1)*u11/((1+.2014969912*(y(6)/(-.8432253... \\ & 97+.2982456141*y(10)+.3033911275*S1))^2.5)*(-43.544956... \\ & 14+11.42178362*S1)); \end{aligned}$$

$$\begin{aligned} dx16= & 842.4618992*(y(6)/(-.843225397+.2982456141*y(10)+.3033... \\ & 911275*S1))^2.5*(-5.078125000+1.302083333*S1)*u11/((1+... \\ & .2014969912*(y(6)/(-.843225397+.2982456141*y(10)+.3033... \\ & 911275*S1))^2.5)*(-43.54495614+11.42178362*S1))-14.965... \\ & 01367*y(7)*u12/(1+.5102040816*y(7)); \end{aligned}$$

```

dx25=5997.552019*(.6653791579*y(4)*(4-y(8))-335.00*y(5)*y(8...
)))*u7/((1+.2994206211*y(4)+10*y(5))*(9.888888888+47.77...
777778*y(8))-1733.986128*(78.27990093*y(4)*y(8)-.1822...
916667e-1*(5.160000001-1.000000000*y(4)-.4300000001e-1...
*y(2)-.8600000002e-1*y(3)-.4300000001e-1*y(5)-.430000...
001e-1*y(9))*(4-y(8)))*u13/((1.806250000+1.017948514*y...
(4)-.6718750002e-2*y(2)-.1343750000e-1*y(3)-.671875000...
2e-2*y(5)-.6718750002e-2*y(9))*(7.666666668+65.0000000...
0*y(8)));

```

```

dx36=-219825.8276*(2.539062500+.5*y(9)-.6510416665*S)*y(1)*...
u2/((-17.41410954+4.310344828*y(9)+4.721566551*S)*(1+1...
0*y(1)))-25904.26449*y(2)^1.2*(2.539062500+.5*y(9)-.65...
10416665*S)*u4/((1+.2116378409*y(2)^1.2)*(98.65625000+...
19.23076923*y(9)-25.04006410*S))+2611.179110*(200*y(5)...
*(-5.078125000+1.302083333*S)-.2595828537e-1*y(6))*(2.5...
39062500+.5*y(9)-.6510416665*S))*u8/((1+20*y(5)+.25958...
28536*y(6))*(-41.02586207+10.77586207*S+1.724137931*y(...
9)))+1333.322667*(5.160000001-1.000000000*y(4)-.430000...
0001e-1*y(2)-.8600000002e-1*y(3)-.4300000001e-1*y(5)-...
4300000001e-1*y(9))*(-5.078125000+1.302083333*S)*u17/(...
(2.011764706-.1960784314*y(4)-.8431372552e-2*y(2)-.168...
6274510e-1*y(3)-.8431372552e-2*y(5)-.8431372552e-2*y(9...
)))*(-27.95422149+7.424159353*S+2.631578948*y(9)));

```

```

dx37=842.4618992*(y(6)/(-.843225397+.2982456141*y(10)+.3033...
911275*S1))^2.5*(-5.078125000+1.302083333*S1)*u11/((1+...
.2014969912*(y(6)/(-.843225397+.2982456141*y(10)+.3033...
911275*S1))^2.5)*(-43.54495614+11.42178362*S1))-9.1660...
70870*(2.539062500+.5*y(10)-.6510416665*S1)*u19/(-5.07...
8125000+1.302083333*S1);

```

```

F=[dx1;dx30;dx5;dx31;dx12;dx35;dx16;dx25;dx36;dx37];

```

The program, which solves the system of differential equations

The Matlab code below is the code to determine the state trajectory for a set of the state variables, for which a differential equation exists in the system.

```

format long

```

```

tInitial=0;

```

```

tFinal=30;

%Determining the state trajectory:
yInitial=[0.02975407611889;0.56817742084615;29.818610444363...
          76;1.56315490307066;0.03797123507339;1.6652717578...
          9899;21.48049625131047;0.11523189828208;4.9443408...
          4977207;6.60862353427018];
tSpan=[tInitial tFinal];
fname='tryprbruc1';
options=odeset('AbsTol',0.00000001,'RelTol',0.000001,'stats',...
              'on');

[t,y]=ode45(fname,tSpan,yInitial);

%Plotting of the state trajectory:
subplot(3,2,1), plot(t,y(:,1))
subplot(3,2,2), plot(t,y(:,2))
subplot(3,2,3), plot(t,y(:,3))
subplot(3,2,4), plot(t,y(:,4))
subplot(3,2,5), plot(t,y(:,5))
subplot(3,2,6), plot(t,y(:,6))
figure
subplot(2,2,1), plot(t,y(:,7))
subplot(2,2,2), plot(t,y(:,8))
subplot(2,2,3), plot(t,y(:,9))
subplot(2,2,4), plot(t,y(:,10))

%Algebraic relations:
a=size(y);
x1=y(a(1),1);
x2=5;
x3=y(a(1),2)/(1+0.29);
x4=y(a(1),2)-y(a(1),2)/(1+0.29);
x5=y(a(1),3);
x6=2.539062500+0.5*y(a(1),9)-0.6510416665*sqrt((3.9 + 0.768*...
          y(a(1),9))^2 -1.357824*y(a(1),9)^2);
x7=-5.078125000+1.302083333*sqrt((3.9 + 0.768*y(a(1),9))^2-1...
          .357824*y(a(1),9)^2);
x8=6.439062500-0.5*y(a(1),9)-0.6510416665*sqrt((3.9+0.768*y(...
          a(1),9))^2-1.357824*y(a(1),9)^2);
x9=(y(a(1),4)*(1+22.25581396))/((1+22.25581396)+0.045);
x10=0.045*((y(a(1),4)*(1+22.25581396))/((1+22.25581396)+0.04...
          5));
x11=5.159999999-1.000000000*y(a(1),4)-.4299999999e-1*y(a(1),...

```

```

2)-.8599999998e-1*y(a(1),3)-.4299999999e-1*y(a(1),5)-.42...
99999999e-1*y(a(1),9); x12=y(a(1),5); x13=0;
x14=y(a(1),6)*(1+22.25581396)/((1+22.25581396)+0.187*22.2558...
1396+0.187*6.7*22.25581396);
x15=(y(a(1),6)*(1+22.25581396)/((1+22.25581396)+0.187*22.255...
81396+0.187*6.7*22.25581396))*0.187*6.7;
x16=y(a(1),7);
x17=2.539062500+0.5*y(a(1),10)-0.6510416665*sqrt((3.9 + 0.76...
8*y(a(1),10))^2-1.357824*y(a(1),10)^2);
x18=-5.078125000+1.302083333*sqrt((3.9 + 0.768*y(a(1),10))^2...
-1.357824*y(a(1),10)^2);
x19=6.439062500-0.5*y(a(1),10)-0.6510416665*sqrt((3.9+0.768*...
y(a(1),10))^2-1.357824*y(a(1),10)^2);
x20=(y(a(1),4)*(1+22.25581396)/((1+22.25581396)+0.045);
x21=5.159999999-1.000000000*y(a(1),4)-.4299999999e-1*y(a(1),2...
)-.8599999998e-1*y(a(1),3)-.4299999999e-1*y(a(1),5)-.4299...
999999e-1*y(a(1),9);
x24=4-y(a(1),8);
x25=y(a(1),8);
x28=5.159999999-1.000000000*y(a(1),4)-.4299999999e-1*y(a(1),2)...
-.8599999998e-1*y(a(1),3)-.4299999999e-1*y(a(1),5)-.429999...
9999e-1*y(a(1),9);
x29=(y(a(1),4)*(1+22.25581396)/((1+22.25581396)+0.045);
x30=y(a(1),2);
x31=y(a(1),4);
x32=(y(a(1),6)*(1+22.25581396)/((1+22.25581396)+0.187*22.25581...
396+0.187*6.7*22.25581396))*0.187*6.7/(0.187*6.7);
x33=(y(a(1),6)*(1+22.25581396)/((1+22.25581396)+0.187*22.25581...
396+0.187*6.7*22.25581396))*0.187*6.7/(0.187*6.7);
x34=(y(a(1),6)*(1+22.25581396)/((1+22.25581396)+0.187*22.25581...
396+0.187*6.7*22.25581396))*0.187*6.7/(0.187*6.7)*0.187;
x35=y(a(1),6);
x36=y(a(1),9);
x37=y(a(1),10);

v1=x6/x7;
v2=x17/x18;
v3=y(a(1),8)/(4-y(a(1),8));
y(a(1),:)

```

Steady state values

Starting with an initial values, for $x_1, x_{30}, x_5, x_{31}, x_{12}, x_{35}, x_{16}, x_{36}$ and x_{37} , a steady state is determined, by use of the above Matlab program. The initial vector, which is used is $[1, 1, 1, 1, 1, 1, 1, 1, 1, 1]$. For other initial vectors the same results are obtained. The steady state is obtained for both aerobic, $u_{17} = 0$, and anaerobic, $u_{15} = 0$, conditions, which can be find in the following table.

Table A.5.5: the steady state concentrations under aerobic and anaerobic conditions.

| State variable | Steady state concentration (mM) aerobic | Steady state concentration (mM) anaerobic |
|----------------|---|---|
| x_1 | 0.0561 | 0.1023 |
| x_2 | 5.0000 | 5.0000 |
| x_3 | 0.4411 | 0.4416 |
| x_4 | 0.1279 | 0.1281 |
| x_5 | 25.7975 | 2.3466 |
| x_6 | 0.7817 | 0.4071 |
| x_7 | 1.6251 | 1.3913 |
| x_8 | 1.4933 | 2.1015 |
| x_9 | 1.6493 | 0.6102 |
| x_{10} | 0.0742 | 0.0275 |
| x_{11} | 1.1261 | 4.2271 |
| x_{12} | 0.0280 | 0.0097 |
| x_{13} | 0.0000 | 0.0000 |
| x_{14} | 0.6833 | 0.4566 |
| x_{15} | 0.8561 | 0.5721 |
| x_{16} | 21.4393 | 1.5760 |
| x_{17} | 2.8010 | 2.0329 |
| x_{18} | 2.8010 | 1.4254 |
| x_{19} | 0.1439 | 0.4417 |
| x_{20} | 1.6493 | 0.6102 |
| x_{21} | 1.1261 | 4.2271 |
| x_{24} | 3.8601 | 3.8469 |
| x_{25} | 0.1399 | 0.1531 |
| x_{28} | 1.1261 | 4.2271 |
| x_{29} | 1.6493 | 0.6102 |
| x_{30} | 0.5690 | 0.5697 |
| x_{31} | 1.6525 | 0.6113 |
| x_{32} | 0.6833 | 0.4566 |
| x_{33} | 0.6833 | 0.4566 |
| x_{34} | 0.1278 | 0.0854 |
| x_{35} | 1.6248 | 1.0858 |
| x_{36} | 3.1884 | 2.2056 |
| x_{37} | 6.5570 | 5.4912 |

Figures are determined for the state trajectories. For both the aerobic and the anaerobic case, figures are plotted for $t_{Final}=1$ and for $t_{Final}=5$ minutes. The following figures are obtained under aerobic conditions:

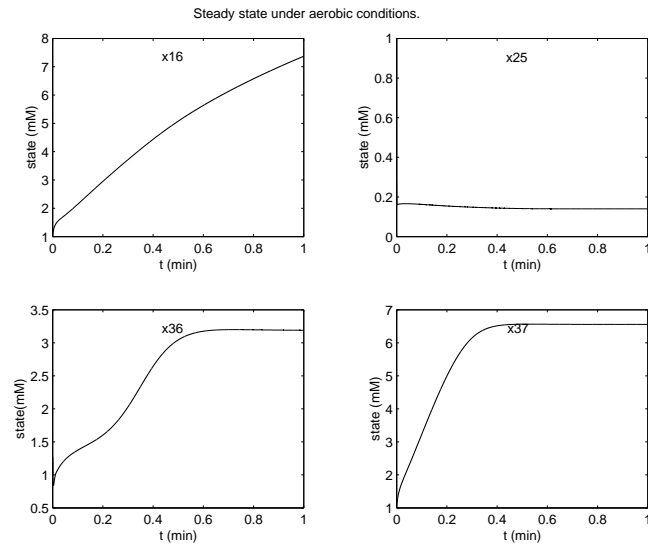
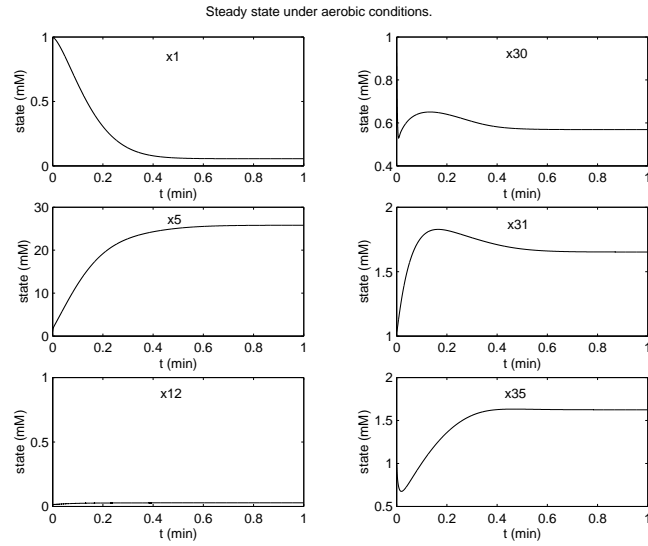

Steady state under aerobic conditions.

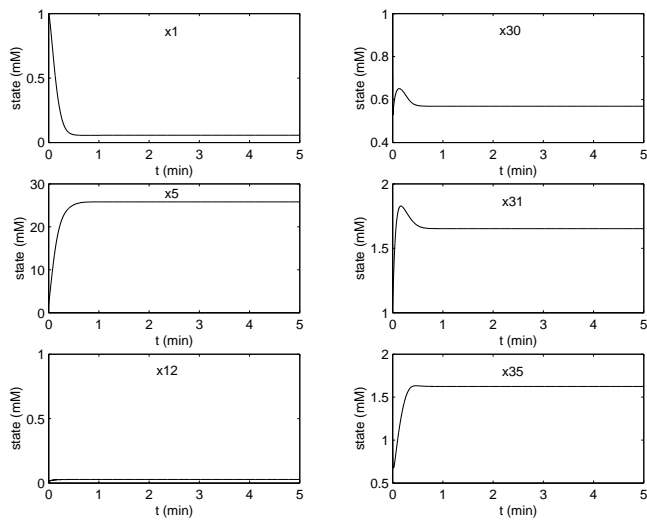

Steady state under aerobic conditions.

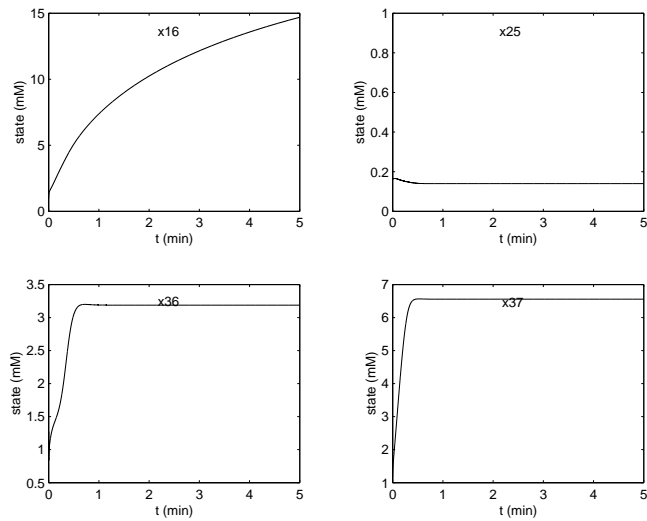

The following figures are obtained under anaerobic conditions:

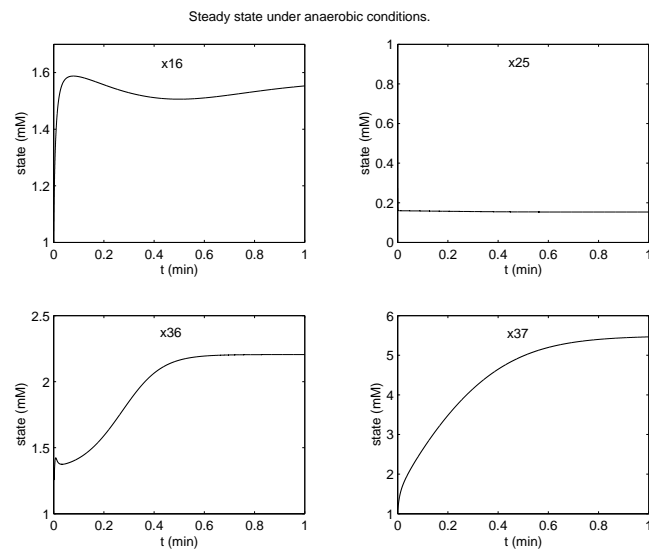
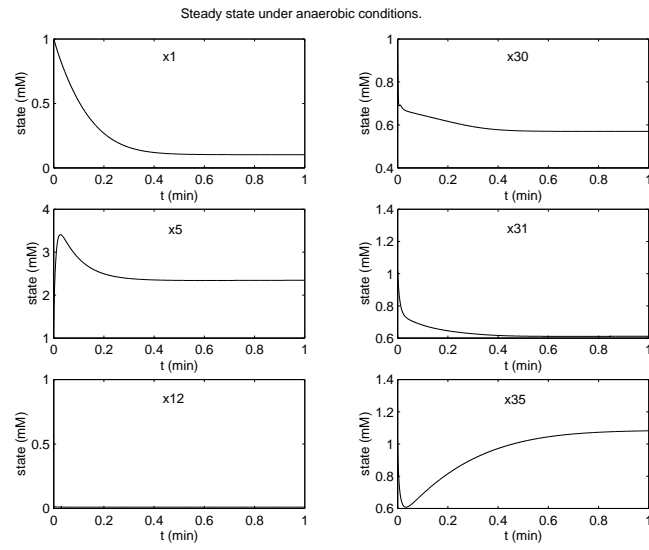

Steady state under anaerobic conditions.

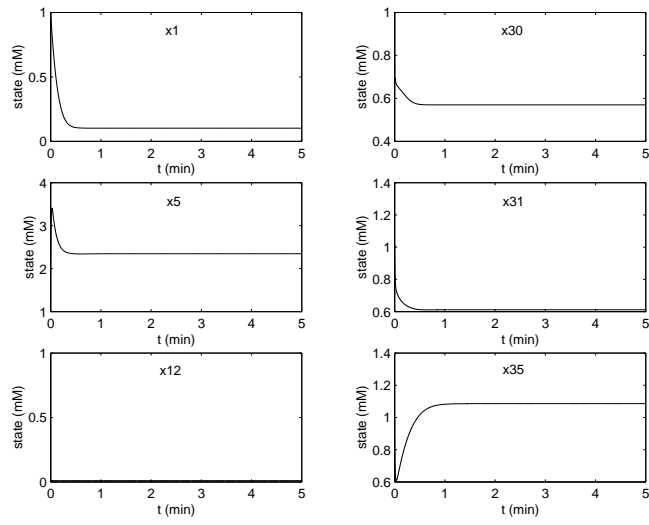

Steady state under anaerobic conditions.

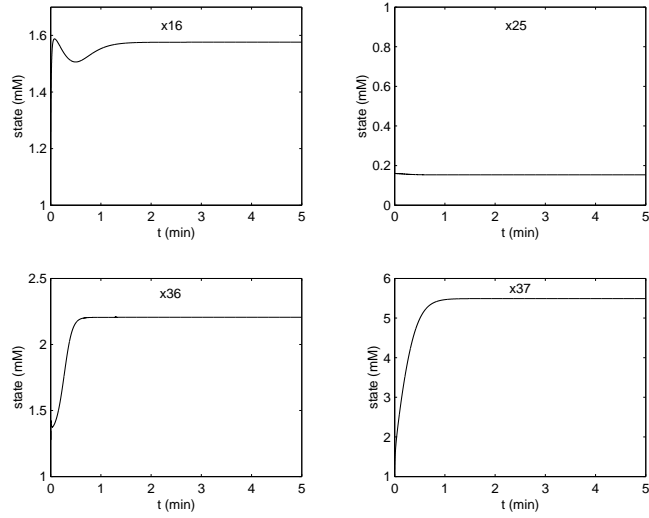

A.6 Control of the output, ATP, of the system

In this section the results of zeroing the output variable ATP are denoted. First the Graph has to be formulated as explained in Section 5.4. After formulating the graph, the Maple program, which is used to determine whether there does not exist a path between Glucose and ATP is denoted. Finally the results obtained by Maple are checked numerical, by determining the steady state values.

A.6.1 Formulation for the Graph

As discussed in Section 5.3 and edge (i, k) , $k \rightarrow i$ exists if or there exist a reaction from complex k to complex i , or k is part of complex i and the complex is consumed or i is part of the complex k and i is consumed after production of the complex k , here $i, k \in I$, which is the set of nodes. The edges in the graph are labeled by u_i , $i = 1, \dots, 21$, the input variables of the reactions catalyzed by the enzymes.

The set of species of which the complexes in the graph exist is $\{S_1, \dots, S_{30}\}$, which are 30 in total. The set of complexes is:

| | | | | | |
|----|-------------------|----|---------------------|----|------------------------------|
| 1 | S_2 | 11 | S_9 | 21 | S_{24} |
| 2 | S_1 | 12 | $S_9 + S_{25}$ | 22 | S_{25} |
| 3 | $S_1 + S_6$ | 13 | $S_{11} + S_{24}$ | 23 | $S_{12} + S_{25}$ |
| 4 | $S_3 + S_7$ | 14 | S_{11} | 24 | S_{12} |
| 5 | S_3 | 15 | $S_{11} + S_7$ | 25 | $S_{12} + S_7$ |
| 6 | S_4 | 16 | $S_{13} + S_6$ | 26 | $S_{14} + S_6$ |
| 7 | $S_4 + S_6$ | 17 | S_{13} | 27 | S_{14} |
| 8 | $S_5 + S_7$ | 18 | S_{26} | 28 | S_{32} |
| 9 | S_5 | 19 | S_{10} | 29 | S_{34} |
| 10 | $S_9 + S_{10}$ | 20 | $S_{10} + S_{24}$ | 30 | S_{15} |
| 31 | $S_{15} + S_{18}$ | 41 | S_{17} | 51 | $\frac{1}{2}S_{23} + S_{21}$ |
| 32 | $S_{16} + S_{17}$ | 42 | S_{19} | 52 | S_{21} |
| 33 | S_{16} | 43 | $S_{19} + S_{17}$ | | |
| 34 | S_{27} | 44 | S_{37} | | |
| 35 | S_6 | 45 | $S_{18} + S_{37}$ | | |
| 36 | S_7 | 46 | $2S_{18}$ | | |
| 37 | $2S_7$ | 47 | S_{22} | | |
| 38 | S_8 | 48 | $S_{20} + S_{22}$ | | |
| 39 | $S_6 + S_8$ | 49 | S_{20} | | |
| 40 | S_{18} | 50 | $\frac{1}{2}S_{23}$ | | |

Table A.6.1 is a table of edges and labels of the edges:

Table A.6.1: edges and labels of edges

| | Edges | u_i | | Edges | u_i |
|----|-----------------------------------|----------|----|---|-----------------|
| 1 | (S_2, S_1) | u_1 | 60 | (S_{32}, S_{34}) | u_9 |
| 2 | (S_1, S_2) | u_1 | 61 | (S_{34}, S_{32}) | u_9 |
| 3 | $(S_1, S_1 + S_6)$ | | 62 | (S_{34}, S_{15}) | u_{10} |
| 4 | $(S_1 + S_6, S_1)$ | | 63 | (S_{15}, S_{34}) | u_{10} |
| 5 | $(S_1 + S_6, S_3 + S_7)$ | u_2 | 64 | $(S_{15}, S_{15} + S_{18})$ | |
| 6 | $(S_3 + S_7, S_3)$ | | 65 | $(S_{15} + S_{18}, S_{15})$ | |
| 7 | $(S_3, S_3 + S_7)$ | | 66 | $(S_{15} + S_{18}, S_{16} + S_{17})$ | u_{11} |
| 8 | (S_3, S_4) | u_3 | 67 | $(S_{16} + S_{17}, S_{16})$ | |
| 9 | (S_4, S_3) | u_3 | 68 | $(S_{16}, S_{16} + S_{17})$ | |
| 10 | $(S_4, S_4 + S_6)$ | | 69 | (S_{16}, S_{27}) | u_{12} |
| 11 | $(S_4 + S_6, S_4)$ | | 70 | (S_9, S_{20}) | u_{16} |
| 12 | $(S_4 + S_6, S_5 + S_7)$ | u_4 | 71 | (S_{20}, S_9) | u_{16} |
| 13 | $(S_5 + S_7, S_4 + S_6)$ | u_4 | 72 | $(S_{20}, S_{20} + S_{22})$ | |
| 14 | $(S_5 + S_7, S_5)$ | | 73 | $(S_{20} + S_{22}, S_{20})$ | |
| 15 | $(S_5, S_5 + S_7)$ | | 74 | $(S_{20} + S_{22}, S_{22})$ | |
| 16 | $(S_5, S_9 + S_{10})$ | u_5 | 75 | $(S_{22}, S_{20} + S_{22})$ | |
| 17 | $(S_9 + S_{10}, S_5)$ | u_5 | 76 | $(\frac{1}{2}S_{23} + S_{21}, S_{20} + S_{22})$ | u_{15} |
| 18 | $(S_9 + S_{10}, S_9)$ | | 77 | $(\frac{1}{2}S_{23} + S_{21}, \frac{1}{2}S_{23})$ | |
| 19 | $(S_9, S_9 + S_{10})$ | | 78 | $(\frac{1}{2}S_{23}, \frac{1}{2}S_{23} + S_{21})$ | |
| 20 | $(S_9 + S_{10}, S_{10})$ | | 79 | $(\frac{1}{2}S_{23} + S_{21}, S_{21})$ | |
| 21 | $(S_{10}, S_9 + S_{10})$ | | 80 | $(S_{21}, \frac{1}{2}S_{23} + S_{21})$ | |
| 22 | (S_9, S_{10}) | u_6 | 81 | (S_{21}, S_{11}) | u_{14} |
| 23 | (S_{10}, S_9) | u_6 | 82 | (S_{11}, S_{21}) | u_{14} |
| 24 | $(S_9, S_9 + S_{25})$ | | 83 | $(S_{18}, S_{15} + S_{18})$ | u_{11} |
| 25 | $(S_9 + S_{25}, S_9)$ | | 84 | $(S_{16} + S_{17}, S_{17})$ | u_{11} |
| 26 | $(S_9 + S_{25}, S_{11} + S_{24})$ | u_{13} | 85 | $(S_{18}, S_{18} + S_{37})$ | u_{19} |
| 27 | $(S_{11} + S_{24}, S_9 + S_{25})$ | u_{13} | 86 | $(S_{18} + S_{37}, S_{18})$ | u_{19} |
| 28 | $(S_{11} + S_{24}, S_{11})$ | | 87 | $(S_{37}, S_{18} + S_{37})$ | u_{19} |
| 29 | $(S_{11}, S_{11} + S_{24})$ | | 88 | $(S_{18} + S_{37}, S_{37})$ | u_{19} |
| 30 | $(S_{11}), S_{11} + S_7$ | | 89 | $(S_{18}, 2S_{18})$ | u_{21} |
| 31 | $(S_{11} + S_7, S_{11})$ | | 90 | $(2S_{18}, S_{18})$ | u_{21} |
| 32 | $(S_{11} + S_7, S_{13} + S_6)$ | u_{17} | 91 | $(S_{17}, S_{18} + S_{37})$ | u_{19} |
| 33 | $(S_{13} + S_6, S_{11} + S_7)$ | u_{17} | 92 | $(S_{17}, S_{19} + S_{17})$ | u_{21} |
| 34 | $(S_{13} + S_6)$ | | 93 | $(S_{19} + S_{17}, S_{17})$ | u_{21} |
| 35 | $(S_{13}, S_{13} + S_6)$ | | 94 | $(S_{19} + S_{17}, S_{19})$ | u_{21} |
| 36 | (S_{13}, S_{26}) | u_{18} | 95 | $(S_{19}, S_{19} + S_{17})$ | u_{21} |
| 37 | (S_{26}, S_{13}) | u_{18} | 96 | $(S_6, S_1 + S_6)$ | u_2 |
| 38 | $(S_{24}, S_{11} + S_{24})$ | u_{13} | 97 | $(S_6, S_4 + S_6)$ | u_3, u_4 |
| 39 | $(S_{11} + S_{24}, S_{24})$ | u_{13} | 98 | $(S_3 + S_7, S_7)$ | u_2, u_3, u_4 |

| | Edges | u_i | | Edges | u_i |
|----|--------------------------------------|----------|-----|------------------------------|-------------------------|
| 40 | $(S_9 + S_{25}, S_{25})$ | u_{13} | 99 | $(S_5 + S_7, S_7)$ | u_4 |
| 41 | $(S_{25}, S_9 + S_{25})$ | u_{13} | 100 | $(S_7, 2S_7)$ | u_{20} |
| 42 | $(S_{24}, S_{10} + S_{24})$ | u_7 | 101 | $(2S_7, S_7)$ | u_{20} |
| 43 | $(S_{10} + S_{24}, S_{24})$ | u_7 | 102 | $(2S_7, S_6 + S_8)$ | u_{20} |
| 44 | $(S_{25}, S_{12} + S_{25})$ | u_7 | 103 | $(S_6 + S_8, 2S_7)$ | u_{20} |
| 45 | $(S_{12} + S_{25}, S_{25})$ | u_7 | 104 | $(S_8, S_6 + S_8)$ | u_{20} |
| 46 | $(S_{10}, S_{10} + S_{24})$ | | 105 | $(S_{19} + S_{17}, 2S_{18})$ | u_{21} |
| 47 | $(S_{10} + S_{24}, S_{10})$ | | 106 | $(2S_{18}, S_{19} + S_{17})$ | u_{21} |
| 48 | $(S_{10} + S_{24}, S_{12} + S_{25})$ | u_7 | 107 | $(S_6 + S_8, S_8)$ | u_{20} |
| 49 | $(S_{12} + S_{25}, S_{10} + S_{24})$ | u_7 | 108 | $(S_6, S_6 + S_8)$ | u_{20} |
| 50 | $(S_{12} + S_{25}, S_{12})$ | | 109 | $(S_6 + S_8, S_6)$ | u_{20} |
| 51 | $(S_{12}, S_{12} + S_{25})$ | | 110 | $(S_7, S_{11} + S_7)$ | u_5, u_{17} |
| 52 | $(S_{12}, S_{12} + S_7)$ | | 111 | $(S_{11} + S_7, S_7)$ | u_5, u_{13}, u_{17} |
| 53 | $(S_{12} + S_7, S_{12})$ | | 112 | $(S_{12} + S_7, S_7)$ | u_5, u_7, u_8, u_{13} |
| 54 | $(S_{12} + S_7, S_{14} + S_6)$ | u_8 | 113 | $(S_7, S_{12} + S_7)$ | u_5, u_7, u_8 |
| 55 | $(S_{14} + S_6, S_{12} + S_7)$ | u_8 | 114 | $(S_{13} + S_6, S_6)$ | u_5, u_{13}, u_{17} |
| 56 | $(S_{14} + S_6, S_{14})$ | | 115 | $(S_6, S_{13} + S_6)$ | u_5, u_{13}, u_{17} |
| 57 | $(S_{14}, S_{14} + S_6)$ | | 116 | $(S_{14} + S_6, S_6)$ | u_5, u_7, u_8 |
| 58 | (S_{14}, S_{32}) | | 117 | $(S_6, S_{14} + S_6)$ | u_5, u_7, u_8 |
| 59 | (S_{32}, S_{14}) | | | | |

These edges and labels are used to obtain the graph, which is the following:

Graph, used for control of the output variables

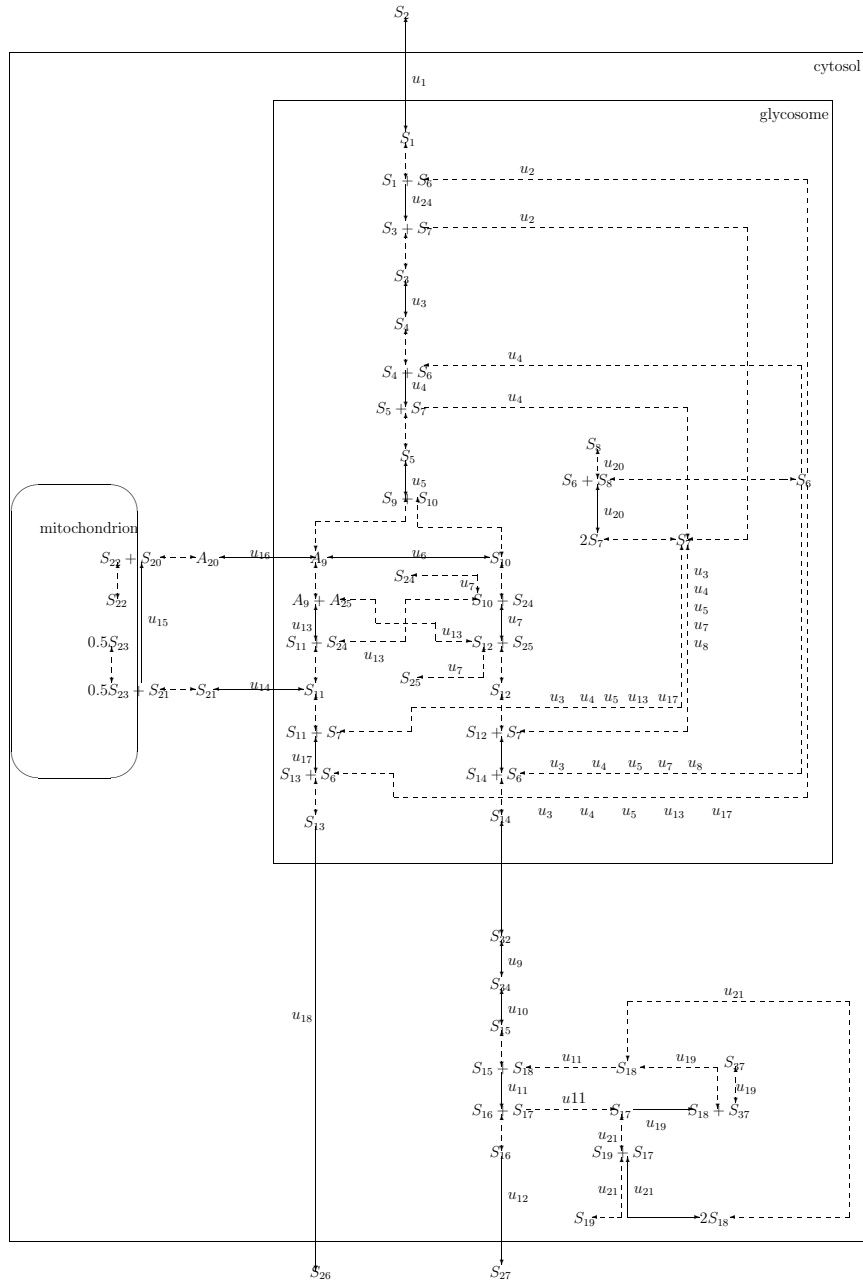

A.6.2 Maple program for the graph theoretic approach

To determine whether a path exists between inflow and outflow the Maple program below will be used. In the case of glycolysis in *Trypanosoma brucei* the inflow is taken as glucose and the outflow as ATP. The program is explained in Section 5.4.

```
> restart:
> with(networks):
> with(linalg):

> PathExists:=proc(G,v1,v2)
  local i,c,C,path_exists;
  path_exists:=false;
  C:= components(G);
  for c in C do
    if member(v1, c)
      and member(v2, c) then
        path_exists:=true;
      fi;
    od;
  path_exists;
end:

> TrypBruc:=proc(U)
  local n,m,C,G,T:
  global P,e1,e2:
  e1:=1: e2:=35:
  new(Gf):
  addvertex({1,2,3,4,5,6,7,8,9,10,11,12,13,14,15,16,17,18,19,20,
    21,22,23,24,25,26,27,28,29,30,31,32,33,34,35,36,37,
    38,39,40,41,42,43,44,45,46,47,48,49,50,51,52},Gf):
  addedge([ [1,2], [2,1], [2,3], [3,2], [3,4], [4,5], [5,4], [5,6],
    [6,5], [6,7], [7,6], [7,8], [8,9], [9,8], [9,10], [10,9],
    [10,11], [11,10], [10,19], [19,10], [11,19], [19,11],
    [12,11], [11,12], [12,13], [13,12], [13,14], [14,13],
    [14,15], [15,14], [15,16], [16,15], [16,17], [17,16],
    [17,18], [18,17], [21,13], [13,21], [12,22], [22,12],
    [21,20], [20,21], [22,23], [23,22], [19,20], [20,19],
    [20,23], [23,20], [23,24], [24,23], [24,25], [25,24],
    [25,26], [26,25], [26,27], [27,26], [27,28], [28,27],
    [28,29], [29,28], [29,30], [30,29], [30,31], [31,30],
    [31,32], [32,33], [33,32], [33,34], [11,49], [49,11],
    [49,48], [48,49], [47,48], [48,47], [51,48], [51,50],
```

```

[50,51],[51,52],[52,51],[52,14],[14,52],[40,31],
[32,41],[40,45],[45,40],[44,45],[45,44],[40,46],
[46,40],[41,45],[43,41],[41,43],[42,43],[43,42],
[35,3],[35,7],[4,36],[8,36],[37,36],[36,37],
[37,39],[39,37],[38,39],[43,46],[46,43],[39,35],
[35,39],[39,38],[15,36],[36,15],[36,25],[25,36],
[16,35],[35,16],[26,35],[35,26]],names=[edg1,edg2,
edg3,edg4,edg5,edg6,edg7,edg8,edg9,edg10,edg11,
edg12,edg13,edg14,edg15,edg16,edg17,edg18,edg19,
edg20,edg21,edg22,edg23,edg24,edg25,edg26,edg27,
edg28,edg29,edg30,edg31,edg32,edg33,edg34,edg35,
edg36,edg37,edg38,edg39,edg40,edg41,edg42,edg43,
edg44,edg45,edg46,edg47,edg48,edg49,edg50,edg51,
edg52,edg53,edg54,edg55,edg56,edg57,edg58,edg59,
edg60,edg61,edg62,edg63,edg64,edg65,edg66,edg67,
edg68,edg69,edg70,edg71,edg72,edg73,edg74,edg75,
edg76,edg77,edg78,edg79,edg80,edg81,edg82,edg83,
edg84,edg85,edg86,edg87,edg88,edg89,edg90,edg91,
edg92,edg93,edg94,edg95,edg96,edg97,edg98,edg99,
edg100,edg101,edg102,edg103,edg104,edg105,edg106,
edg107,edg108,edg109,edg110,edg111,edg112,edg113,
edg114,edg115,edg116],Gf):
G:=Gf:
if U[1]=0 then delete({edg1,edg2},G) fi:
if U[2]=0 then delete({edg5},G) fi:
if U[3]=0 then delete({edg8,edg9},G) fi:
if U[4]=0 then delete({edg12},G) fi:
if U[5]=0 then delete({edg15,edg16},G) fi:
if U[6]=0 then delete({edg21,edg22},G) fi:
if U[7]=0 then delete({edg44,edg41,edg42,edg43,edg47,
edg48},G) fi:
if U[8]=0 then delete({edg54,edg53},G) fi:
if U[9]=0 then delete({edg60,edg59},G) fi:
if U[10]=0 then delete({edg61,edg62},G) fi:
if U[11]=0 then delete({edg65,edg83,edg82},G) fi:
if U[12]=0 then delete({edg68},G) fi:
if U[13]=0 then delete({edg25,edg26,edg37,edg38,edg39,
edg40},G) fi:
if U[14]=0 then delete({edg80,edg81},G) fi:
if U[15]=0 then delete({edg75},G) fi:
if U[16]=0 then delete({edg69,edg70},G) fi:
if U[17]=0 then delete({edg31,edg32},G) fi:
if U[18]=0 then delete({edg35,edg36},G) fi:
if U[19]=0 then delete({edg90,edg87,edg86,edg85,

```

```

                                edg84},G) fi:
if U[20]=0 then delete({edg107,edg106,edg103,edg108,edg102,
                                edg101,edg100,edg99},G) fi:
if U[21]=0 then delete({edg88,edg89,edg93,edg94,edg92,edg91,
                                edg105,edg104},G) fi:
if U[2]=0 or U[3]=0 or U[4]=0 or U[5]=0 or U[7]=0 or U[8]=0
    then delete({edg95},G) fi:
if U[4]=0 or U[5]=0 or U[7]=0 or U[8]=0 then delete({edg96},G)
fi:
if U[5]=0 or U[13]=0 or U[17]=0 then delete({edg114,edg113,
edg109,edg110},G) fi:
if U[5]=0 or U[7]=0 or U[8]=0 then delete({edg115,edg116},G)
fi:
if U[5]=0 or U[7]=0 or U[8]=0 or U[13]=0 then delete({edg111,
edg112},G) fi:
delete({edg97,edg98},G);

T:=shortpathtree(G,1);
n:=path([e1,e2],T):
P:=PathExists(T,e1,e2):
if not P then
    print('No path exists from glucose to ATP produce in the
        glycosome.')
    else
    print('This is a path from glucose to ATP produce in the
        glycosome'):
    print(n);
fi:
end:

> FindPath1:=proc()
    local i,j,TB1,u: global k:
    for i from 1 to 21 do
    u:=vector([1,1,1,1,1,1,1,1,1,1,1,1,1,1,1,1,1,1,1,1,1]);
    u[i]:=0; u[17]:=0; print(u);
    TB1(i):=TrypBruc(u);
    if not P then k(i):=0 else k(i):=1 fi:
    od:
    k:=vector([k(1),k(2),k(3),k(4),k(5),k(6),k(7),k(8),k(9),
        k(10),k(11),k(12),k(13),k(14),k(15),k(16),k(17),
        k(18),k(19),k(20),k(21)]);
end:

> FindPath2:=proc()

```

```

local i,j,u:
global l:
l:=k:
print(l);
for i from 1 to 21 do
  for j from 1 to 21 do
    u:=vector([1,1,1,1,1,1,1,1,1,1,1,1,1,1,1,1,1,1,1,1,1]);
    if not i>=j then
      if k[i]=1 and k[j]=1 then u[i]:=0; u[j]:=0; u[17]:=0;
        print(u); TB2(i):=TrypBruc(u);
        if not P then l[i]:=0; l[j]:=0;
      fi:
    fi:
  fi:
od:
od:
print(l);
end:

```

```

> FindPath3:=proc()
  local i,j,t,u:
  global g:
  g:=1:
  print(g);
  for i from 1 to 21 do
    for j from 1 to 21 do
      for t from 1 to 21 do
        u:=vector([1,1,1,1,1,1,1,1,1,1,1,1,1,1,1,1,1,1,1,1,1]);
        if not i>=j and not j>=t then
          if g[i]=1 and g[j]=1 and g[t]=1 then
            u[i]:=0; u[j]:=0;
            u[t]:=0; u[17]:=0;
            print(u);
            TB3(i):=TrypBruc(u);
            if not P then g[i]:=0; g[j]:=0; g[t]:=0;
          fi:
        fi:
      fi:
    od:
  od:
od:
od:
print(g);
end:

```

A.6.3 Numerical determination of steady state

For the model of *Trypanosoma brucei*, under aerobic condition the steady state is determined numerically for the case that u_1 is equal to zero and for the case that u_4 is equal to zero. For the anaerobic case the results of determining the steady state numerically are denoted for the case that u_1 is equal to zero and for the case that u_7 is equal to zero. The results are denoted in, respectively, Table A.6.2 and Table A.6.3.

Table A.6.2: the steady state concentrations under aerobic conditions

| State variable | Steady state concentration (mM) aerobic ($u_1 = 0$) | Steady state concentration (mM) aerobic ($u_4 = 0$) |
|----------------|---|---|
| x_1 | 4.9995 | 4.9994 |
| x_2 | 5.000 | 5.000 |
| x_3 | 0.2446 | 93.0232 |
| x_4 | 0.0709 | 26.9767 |
| x_5 | 14.8155 | 0.0000 |
| x_6 | 0.0000 | 0.0000 |
| x_7 | 0.0000 | 0.0000 |
| x_8 | 3.9000 | 0.0390 |
| x_9 | 3.8647 | 0.0000 |
| x_{10} | 0.1739 | 0.0000 |
| x_{11} | 0.0001 | 0.0000 |
| x_{12} | 0.0000 | 0.0000 |
| x_{13} | 0.0000 | 0.0000 |
| x_{14} | 0.0024 | 0.0024 |
| x_{15} | 0.0030 | 0.0030 |
| x_{16} | 0.0000 | 0.0000 |
| x_{17} | 0.0000 | 0.0000 |
| x_{18} | 0.0001 | 0.0000 |
| x_{19} | 3.8999 | 3.8998 |
| x_{20} | 3.8647 | 0.0000 |
| x_{21} | 0.0001 | 0.0000 |
| x_{24} | 3.4000 | 3.9650 |
| x_{25} | 0.0000 | 0.0350 |
| x_{28} | 0.0001 | 0.0000 |
| x_{29} | 3.8647 | 0.0000 |
| x_{30} | 0.3156 | 1.2000 |
| x_{31} | 3.8722 | 0.0000 |
| x_{32} | 0.0024 | 0.0024 |
| x_{33} | 0.0024 | 0.0024 |
| x_{34} | 0.0004 | 0.0004 |
| x_{35} | 0.0057 | 0.0057 |
| x_{36} | 0.0000 | 0.0000 |
| x_{37} | 0.0001 | 0.0002 |

Table A.6.3: the steady state concentrations under anaerobic conditions.

| State variable | Steady state concentration (mM) anaerobic ($u_1 = 0$) | Steady state concentration (mM) anaerobic ($u_7 = 0$) |
|----------------|---|---|
| x_1 | 0.0000 | 4.9524 |
| x_2 | 5.0000 | 5.0000 |
| x_3 | 0.0000 | 0.6673 |
| x_4 | 0.0000 | 0.1935 |
| x_5 | 0.8670 | 14.6452 |
| x_6 | 3.9000 | 0.0000 |
| x_7 | 0.0000 | 0.0045 |
| x_8 | 0.0000 | 3.8955 |
| x_9 | 0.5181 | 3.8405 |
| x_{10} | 0.0233 | 0.1728 |
| x_{11} | 4.2074 | 0.0154 |
| x_{12} | 0.5463 | 0.0000 |
| x_{13} | 0.0000 | 0.0000 |
| x_{14} | 0.0026 | 0.0025 |
| x_{15} | 0.0032 | 0.0032 |
| x_{16} | 0.0000 | 0.0000 |
| x_{17} | 0.0000 | 0.0000 |
| x_{18} | 0.0192 | 0.0124 |
| x_{19} | 3.8808 | 3.8875 |
| x_{20} | 0.5181 | 3.8405 |
| x_{21} | 4.2074 | 0.0154 |
| x_{24} | 3.9925 | 3.4000 |
| x_{25} | 0.0075 | 0.0000 |
| x_{28} | 4.2074 | 0.0154 |
| x_{29} | 0.5181 | 3.8405 |
| x_{30} | 0.0000 | 0.8608 |
| x_{31} | 0.5191 | 3.8479 |
| x_{32} | 0.0026 | 0.0025 |
| x_{33} | 0.0026 | 0.0025 |
| x_{34} | 0.0005 | 0.0005 |
| x_{35} | 0.0062 | 0.0061 |
| x_{36} | 7.8000 | 0.0045 |
| x_{37} | 0.0193 | 0.0125 |

Appendix B

List of All Equations

$$(A.1) \quad r_1 = 106.2 \frac{0.5(x_2 - x_1)}{1 + 0.5x_2 + 0.5x_1 + 0.75x_1x_2 \cdot 0.5^2}$$
$$(A.2) \quad r_2 = 625 \frac{8.6207x_6 \cdot 10x_1}{(1 + 8.6207x_6 + 7.9365x_7)(1 + 10x_1)}$$
$$(A.3) \quad r_4 = 780 \frac{(1.2195x_4)^{1.2} (38.4615x_6)}{(1 + (1.2195x_4)^{1.2})(1 + 38.4615 \cdot x_6)}$$
$$(A.4) \quad r_5 = 184.5 \frac{(c_{5,3}x_5 - 1.19 \cdot 66 \frac{2}{3} \cdot 14.9254x_9x_{10})}{1 + c_{5,3}x_5 + 14.9254x_{10} + 66 \frac{2}{3}x_9 + c_{5,3} \cdot 10.2041x_5x_{10} + 66 \frac{2}{3} \cdot 14.9254x_{10}x_9}$$
$$c_{5,3} = \frac{1}{9 \cdot 10^{-3}(1 + 1.4706x_6 + 0.6667x_7 + 0.2703x_8)}$$
$$(A.5) \quad r_7 = 1470 \frac{(6.6667 \cdot 2.2222x_{10}x_{24} - 0.67 \cdot 10 \cdot 50x_{12}x_{25})}{(1 + 6.6667x_{10} + 10x_{12})(1 + 2.2222x_{24} + 50x_{25})}$$
$$(A.6) \quad r_8 = 640 \frac{(20 \cdot 10x_{12}x_7 - 0.029 \cdot 0.6173 \cdot 3.4483x_{14}x_6)}{(1 + 20x_{12} + 0.6173x_{14})(1 + 10x_7 + 3.4483x_6)}$$
$$(A.7) \quad r_{11} = 2.6 \cdot 10^3 \frac{\left(\frac{x_{15}}{0.34 + 0.5965 \cdot x_{17} + 0.5313 \cdot x_{18}} \right)^{2.5} (8.7719x_{18})}{\left(1 + \left(\frac{x_{15}}{0.34 + 0.5965 \cdot x_{17} + 0.5313 \cdot x_{18}} \right)^{2.5} \right) (1 + 8.7719x_{18})}$$
$$(A.8) \quad r_{12} = 160 \frac{0.5102x_{16}}{1 + 0.5102x_{16}}$$
$$(A.10) \quad r_{13} = 425 \frac{(1.1765 \cdot 66.6667x_9x_{25} - 0.07 \cdot 0.1563 \cdot 1.6667x_{11}x_{24})}{(1 + 1.1765x_9 + 0.1563x_{11})(1 + 66.6667x_{25} + 1.6667x_{24})}$$
$$(A.10) \quad r_{15} = 368 \frac{0.5882x_{21}}{1 + 0.5882x_{21}}$$
$$(A.11) \quad r_{17} = 200 \frac{(0.1961x_{11} \cdot 8.3333x_7 - 167x_{13} \cdot 8.3333x_6 \cdot 5.2632)}{(1 + 0.1961x_{11} + 8.3333x_{13})(1 + 8.3333x_7 + 5.2632x_6)}$$
$$(A.12) \quad r_{19} = 50 \frac{x_{17}}{x_{18}}$$

$$(A.13) \quad \dot{x}_1 = 0.1754(r_1 u_1 - r_2 u_2)$$

$$(A.14) \quad \dot{x}_{30} = 4.0799(r_2 u_2 - r_4 u_4)$$

$$(A.15) \quad \dot{x}_5 = 4.0799(r_4 u_4 - r_5 u_5)$$

$$(A.16) \quad \dot{x}_{31} = 0.1754(2r_5 u_5 - r_7 u_7 - r_{13} u_{13} - r_{15} u_{15})$$

$$(A.17) \quad \dot{x}_{12} = 4.0799(r_7 u_7 - r_8 u_8)$$

$$(A.18) \quad \dot{x}_{35} = 0.1754(r_8 u_8 - r_{11} u_{11})$$

$$(A.19) \quad \dot{x}_{16} = 0.1833(r_{11} u_{11} - r_{12} u_{12})$$

$$(A.20) \quad \dot{x}_{25} = 4.0799(r_7 u_7 - r_{13} u_{13})$$

$$(A.21) \quad \dot{x}_{36} = 4.0799(-r_2 u_2 - r_4 u_4 + r_8 u_8 + r_{17} u_{17})$$

$$(A.22) \quad \dot{x}_{37} = 0.1833(r_{11} u_{11} - r_{19} u_{19})$$

$$(A.23) \quad 3.9 = x_6 + x_7 + x_8$$

$$(A.24) \quad 3.9 = x_{17} + x_{18} + x_{19}$$

$$(A.25) \quad 4 = x_{25} + x_{24}$$

$$(A.26) \quad 120 = (x_{28} + x_{29})(1 + 22.2558) + x_3 + x_4 + 2x_5 + x_{10} + x_{12} + 2x_6 + x_7$$

$$(A.27) \quad x_{28} \equiv x_{11} = x_{21}$$

$$(A.28) \quad x_{29} \equiv x_9 = x_{20}$$

$$(A.29) \quad x_{33} \equiv x_{14} = x_{32}$$

$$(A.30) \quad x_{30} \equiv x_3 + x_4$$

$$(A.31) \quad x_{31} \equiv \frac{x_{29}(1+22.2558)+x_{10}}{(1+22.2558)}$$

$$(A.32) \quad x_{35} \equiv \frac{x_{33}(1+22.2558)+x_{34}22.2558+x_{15}22.2558}{(1+22.2558)}$$

$$(A.33) \quad x_{36} \equiv 2x_6 + x_7$$

$$(A.34) \quad x_{37} \equiv 2x_{17} + x_{18}$$

$$(A.35) \quad 0.29 = \frac{x_4}{x_3}$$

$$(A.36) \quad 0.045 = \frac{x_{10}}{x_9}$$

$$(A.37) \quad 0.187 = \frac{x_{34}}{x_{32}}$$

$$(A.38) \quad 6.7 = \frac{x_{15}}{x_{34}}$$

$$(A.39) \quad 0.442 = \frac{x_8 x_6}{(x_7)^2}$$

$$(A.40) \quad 0.442 = \frac{x_{19} x_{17}}{(x_{18})^2}$$

$$(A.41) \quad x_3 = \frac{x_{30}}{1+0.29}$$

$$(A.42) \quad x_{29} = \frac{x_{31}(1+22.2558)}{1+22.2558+0.045}$$

$$(A.43) \quad x_{33} = \frac{x_{35}(1+22.2558)}{1+(1+0.187+0.187 \cdot 6.7)22.2558}$$

Appendix C

List of Abbreviations

| | | |
|----------------|---|--|
| ADP | = | Adenosine diphosphate |
| AK | = | Adenylate kinase |
| ALD | = | Fructose-1,6-bisphosphate aldolase |
| AMP | = | Adenosine monophosphate |
| ATP | = | Adenosine triphosphate |
| 1,3-BPGA | = | 1,3-Bisphosphoglycerate |
| c | = | Cytosolic |
| c _c | = | Cytosolic volume |
| c _g | = | Glycosomal volume |
| c _t | = | Cellular volume |
| DHAP | = | Dihydroxyacetone phosphate |
| en | = | Enzyme |
| ex | = | Extern |
| ENO | = | Enolase |
| Fru-1,6-BP | = | Fructose-1,6-biphosphate |
| Fru-6-P | = | Fructose-6-phosphate |
| g | = | Glycosomal |
| GA-3-P | = | Glyceraldehyde-3-phosphate |
| GAPDH | = | Glyceraldehyde-3-phosphate dehydrogenase |
| GDA | = | Glycerol-3-phosphate dehydrogenase |
| GK | = | Glycerol kinase |
| Glc-6-P | = | Glucose-6-phosphate |
| Gly-3-P | = | Glycerol-3-phosphate |
| GPO | = | Glycerol-3-phosphate oxidase |

| | | |
|-------------------|---|---|
| HK | = | Hexokinase |
| m | = | Mytochondrial |
| NADH | = | Nicotinamide adenine dinucleotide |
| PEP | = | Phosphoenolpyruvate |
| PFK | = | Phosphofructokinase |
| 3-PGA | = | 3-Phosphoglycerate |
| PGI | = | Glucosephosphate isomerase |
| PGK | = | Phosphoglycerate kinase |
| PGM | = | Phosphoglycerate mutase |
| PYK | = | Pyruvate kinase |
| \mathbb{R} | = | Set of real numbers, $(-\infty, \infty)$ |
| \mathbb{R}_+ | = | set of positive real numbers, $\{x \in \mathbb{R} x \geq 0\} = [0, \infty)$ |
| \mathbb{R}_{s+} | = | set of strictly positive real numbers, $(0, \infty)$ |
| t | = | Total |
| TIM | = | Triosephosphate isomerase |

Bibliography

- [1] G. Ausiello, p. Crescendi, G. Gambosi, V. Kahn, A. Marchetti-Spaccamela, and M. Protasi. *Complexity and approximation of combinatorial approximation problems and their approximability properties*. Springer-Verlag, Berlin, 1999.
- [2] Barbara M. Bakker. *Glycolis of Trypanosoma brucei*. PhD thesis, Vrije Universiteit, Amsterdam, The Netherlands, October 1998.
- [3] Barbara M. Bakker, Hans V. Westerhoff, Fred R. Opperdoes, and Paul A.M. Michels. Metabolic control analysis of glycolysis in trypanosomes as an approach to improve selectivity and effectiveness of drugs. *Elsevier*, 2000.
- [4] R.B. Bapat and T.E.S Raghavan. *Nonnegative Matrices and Applications*. Addison Wesley Longman, 1999.
- [5] Paul Blanchard, Robert L. Devaney, and Glen R. Hall. *Differential Equations*. Brooks/Cole Publishing Company, 1 edition, 1998.
- [6] Neil A. Campbell, Jane B. Reece, and Lawrence G. Mitchel. *Biology*. Addison Wesley Longman, 1999.
- [7] Athel Cornish-Bowden. *Fundamentals of Enzyme Kinetics*. Portland Press Ltd, 3 edition, 2003.
- [8] M. Feinberg. *Mathematical aspects of mass action kinetics*. Prentice-Hall, Englewood Cliffs, N.J., 1977.
- [9] M. Feinberg. *Chemical oscillations, multiple equilibria and reaction networks, in Dynamics and Modelling of Reactive Systems*. Academic Press, New York, 1980.
- [10] M. Feinberg. Chemical reaction network structure and the stability of complex isothermal reactors-I. the deficiency zero and deficiency one theorems. *Chemical Engineering Science*, 42(10):2229–2268, 1987.
- [11] M. Feinberg and F.J.M. Horn. Dynamics of open chemical systems and the algebraic structure of the underlying reaction network. *Chem. Engng. Sci.*, 29:775–787, 1974.
- [12] M. Gondran and M. Minoux. *Graphs and algorithms*. John Wiley & Sons, Chichester, 1984.
- [13] Reinhart Heinrich and Stefan Schuster. *The Regulation of Cellular Systems*. Chapman and Hall, 1996.
- [14] F.J.M. Horn. On a connexion between stability and graphs in chemical kinetics, I. stability and the reaction diagram, II. stability and the complex graph. *Proc. R. Soc.*, A334:299–330, 1973.
- [15] Dorina Jibetea. *Algebraic optimization with Applications to System Theory*. PhD thesis, Vrije Universiteit, Amsterdam, The Netherlands, April 2003.
- [16] Klaas Krab. Intracellular Networks. adapted from Molecular Cell Physiology- The complexity of life processes, March 2005.

- [17] George Lindfield and John Penny. *Numerical Methods Using Matlab (2nd. ed.)*. Prentice Hall, New Jersey, 1999.
- [18] K. Rohloff, S. Khuller, and G. Kortsatz. Approximating Optimal Sensor Selections and Connections to Colored st-cut Problems. In Janan Zaytoon, Veronique Carre-Menetrier, Christos Cassandras, and Xiren Cao, editors, *Preprints 7th International Workshop Discrete Event Systems (WODES.2004)*, pages 85–90, Laxenburg, 2004. IFAC.
- [19] K.R. Rohloff and J.H. van Schuppen. Approximating the minimal-cost sensor-selection for discrete-event systems. Report MAS-R0404, CWI, Amsterdam, 2004.
- [20] Kurt R. Rohloff and Jan H. van Schuppen. Approximating minimal communicated event sets for decentralized supervisory control. In *Proceedings IFAC World Congress*, London, 2005. Elsevier.
- [21] Sergio Rossell. Hierarchical and metabolic regulation of glucose influx in starved *Saccharomyces cerevisiae*. *FEMS Yeast Research*, 5:611–619, 2005.
- [22] M. Sipser. *Introduction to the theory of computation*. PWS Publishing Company, Boston, 1997.
- [23] Eduardo D. Sontag. Structure and Stability of Certain Chemical Networks and Applications to the Kinetic Proofreading Model of T-Cell Receptor signal Transduction. *IEEE transactions on automatic control*, 46, July 2001.
- [24] University of Leicester department of Microbiology United Kingdom. www.micro.msb.le.ac.uk. Microbiology @ Leicester.
- [25] Consortium University of Washington department of Biochemistry United States of America. www.sgpp.org/arfrican_sleeping_sickness.html. Structural genomics of pathogenic protozoa.
- [26] Pim van Hoek, Johannes P. van Dijken, and Jack T. Pronk. Regulation of fermentative capacity and levels of glycolytic enzymes in chemostat cultures of *saccharomyces cerevisiae*. *Enzyme and Microbial Technology*, 26:724–736, 2000.
- [27] Charles F. van Loan. *A Matrix-vector Approach Using Matlab*. Prentice Hall, New Jersey, 1999.
- [28] Jan H. van Schuppen. System theory of rational positive systems for cell reaction networks. In Bart De Moor et al., editor, *Proc. MTNS.2004*, Leuven, 2004. Katholieke Universiteit Leuven.
- [29] Jan H. van Schuppen. Control and System Theory of Positive Systems. Course notes, 2005.
- [30] J.H. van Schuppen. Realization and control problems for biochemical reaction networks. In S. Domek and R. Kaszyński, editors, *Proceedings 11th International IEEE Conference on Methods and Models in Automation and Robotics*, New York, 2005. IEEE.